

ROBOTICS

# Product manual

## IRB 1600/1660



Trace back information:  
Workspace R18-2 version a18  
Checked in 2018-11-20  
Skribenta version 5.3.012

## Product manual

IRB 1600 - 5/1.2 type A  
IRB 1600 - 5/1.45 type A  
IRB 1600 - 6/1.2 type A  
IRB 1600 - 6/1.45 type A  
IRB 1600 - 7/1.2 type A  
IRB 1600 - 7/1.45 type A  
IRB 1600 - 8/1.2 type A  
IRB 1600 - 8/1.45 type A  
IRB 1600 - 10/1.2 type A  
IRB 1600 - 10/1.45 type A  
IRB 1600ID - 4/1.5  
IRB 1600ID - 4/1.5 type A  
IRB 1660ID - 6/1.55  
IRB 1660ID - 4/1.55

IRC5

Document ID: 3HAC026660-001

Revision: W

The information in this manual is subject to change without notice and should not be construed as a commitment by ABB. ABB assumes no responsibility for any errors that may appear in this manual.

Except as may be expressly stated anywhere in this manual, nothing herein shall be construed as any kind of guarantee or warranty by ABB for losses, damages to persons or property, fitness for a specific purpose or the like.

In no event shall ABB be liable for incidental or consequential damages arising from use of this manual and products described herein.

This manual and parts thereof must not be reproduced or copied without ABB's written permission.

Keep for future reference.

Additional copies of this manual may be obtained from ABB.

Original instructions.

© Copyright 2006-2018 ABB. All rights reserved.  
Specifications subject to change without notice.

ABB AB, Robotics  
Robotics and Motion  
Se-721 68 Västerås  
Sweden



# Table of contents

Overview of this manual .....	9
Product documentation .....	15
How to read the product manual .....	17
<b>1 Safety</b> .....	<b>19</b>
1.1 General safety information .....	19
1.1.1 Limitation of liability .....	19
1.1.2 Protective stop and emergency stop .....	21
1.2 Safety actions .....	22
1.2.1 Fire extinguishing .....	22
1.2.2 Emergency release of the robot axes .....	23
1.2.3 Make sure that the main power has been switched off .....	24
1.3 Safety risks .....	25
1.3.1 Safety risks during installation and service work on robots .....	25
1.3.2 Moving robots are potentially lethal .....	27
1.3.3 First test run may cause injury or damage .....	28
1.3.4 Work inside the working range of the robot .....	29
1.3.5 Enabling device and hold-to-run functionality .....	30
1.3.6 Risks associated with live electric parts .....	31
1.3.7 The unit is sensitive to ESD .....	33
1.3.8 Hot parts may cause burns .....	34
1.3.9 Safety risks related to pneumatic/hydraulic systems .....	35
1.3.10 Brake testing .....	36
1.3.11 Safety risks during handling of batteries .....	37
1.3.12 Safety risks during work with gearbox lubricants (oil or grease) .....	38
1.4 Safety signals and symbols .....	40
1.4.1 Safety signals in the manual .....	40
1.4.2 Safety symbols on product labels .....	42
<b>2 Installation and commissioning</b> .....	<b>49</b>
2.1 Introduction .....	49
2.2 Unpacking .....	50
2.2.1 Pre-installation procedure .....	50
2.2.2 Working range .....	55
2.2.3 Risk of tipping/stability .....	61
2.3 On-site installation .....	63
2.3.1 Lifting robot with roundslings .....	63
2.3.2 Lifting and turning a suspended mounted robot .....	65
2.3.3 Manually releasing the brakes .....	66
2.3.4 Orienting and securing the robot .....	68
2.3.5 Setting the system parameters for a suspended or tilted robot .....	72
2.3.6 Loads fitted to the robot, stopping time and braking distances .....	78
2.3.7 Fitting equipment on the robot (robot dimensions) .....	79
2.3.8 Installation of signal lamp for 1600 (option) .....	92
2.3.9 Installation of signal lamp for 1600ID/1660ID (option) .....	95
2.3.10 Installation of the wire feeder shelf for 1600ID/1660ID .....	97
2.4 Restricting the working range .....	99
2.4.1 Axes with restricted working range .....	99
2.4.2 Installation of additional mechanical stops on axis 1 .....	100
2.4.3 Installation of additional mechanical stop on axis 2 .....	105
2.4.4 Installation of additional mechanical stops on axis 3 .....	109
2.4.5 Installation of position switch, axis 1 .....	113
2.5 Electrical connections .....	116
2.5.1 Customer connectors on the robot .....	116
2.5.2 Robot cabling and connection points .....	119
2.5.3 Customer connections on the robot .....	123

## Table of contents

---

2.6	Start of robot in cold environments .....	126
<b>3</b>	<b>Maintenance</b> .....	<b>127</b>
3.1	Introduction .....	127
3.2	Maintenance schedule and expected component life .....	128
3.2.1	Specification of maintenance intervals .....	128
3.2.2	Maintenance schedule .....	129
3.2.3	Expected component life .....	131
3.3	Inspection activities .....	132
3.3.1	Inspection, damper axes 2, 3 and 5 .....	132
3.3.2	Inspecting information labels .....	135
3.4	Replacement activities .....	137
3.4.1	Type of lubrication in gearboxes .....	137
3.4.2	Changing the oil in axes 5 and 6 gearboxes .....	138
3.4.3	Changing the oil in axes 5 and axis 5 and 6 gearboxes, IRB 1600ID/1660ID .....	141
3.4.4	Replacing the battery pack .....	144
3.5	Cleaning activities .....	149
3.5.1	Cleaning the IRB 1600/1660ID .....	149
<b>4</b>	<b>Repair</b> .....	<b>153</b>
4.1	Introduction .....	153
4.2	General procedures .....	154
4.2.1	Performing a leak-down test .....	154
4.2.2	Mounting instructions for bearings .....	155
4.2.3	Mounting instructions for seals .....	157
4.2.4	Cut the paint or surface on the robot before replacing parts .....	159
4.2.5	The brake release buttons may be jammed after service work .....	161
4.3	Complete manipulator .....	162
4.3.1	Replacing the cable harness, IRB 1600 .....	162
4.3.2	Replacing the cable harness, 1600ID/1660ID .....	172
4.3.3	Replacement of complete arm system .....	178
4.4	Upper and lower arm .....	183
4.4.1	Replacing the complete upper arm, IRB 1600 .....	183
4.4.2	Replacing the complete upper arm, IRB 1600ID/1660ID .....	188
4.4.3	Replacing the complete lower arm .....	196
4.4.4	Replacing the wrist unit, IRB 1600 .....	201
4.4.5	Replacing the wrist unit, IRB 1600ID .....	206
4.4.6	Replacing the wrist unit, IRB1660ID .....	212
4.4.7	Replacing the damper, axis 2 .....	220
4.4.8	Replacing the damper, axis 3 .....	222
4.4.9	Replacing the mechanical stop axis 3, IRB 1600ID/1660ID .....	224
4.4.10	Replacement of damper, axis 5 .....	226
4.4.11	Remove upper arm AW Gun .....	228
4.4.12	Measuring the play 1600ID/1660ID, axis 5 .....	233
4.4.13	Measuring the play 1600ID/1660ID, axis 6 .....	236
4.5	Frame and base .....	239
4.5.1	Replacement of base .....	239
4.5.2	Replacing the serial measurement unit .....	244
4.5.3	Replacing the push button unit .....	251
4.6	Motors .....	257
4.6.1	Replacement of motor, axis 1 .....	257
4.6.2	Replacement of motor, axis 2 .....	262
4.6.3	Replacement of motor, axis 3, IRB 1600 .....	268
4.6.4	Replacement of motor, axis 3, 1600ID/1660ID .....	273
4.6.5	Replacement of motor, axis 4, IRB 1600 .....	279
4.6.6	Replacement of motor, axis 4, 1600ID/1660ID .....	284
4.6.7	Replacement of motor and timing belt, axis 5, IRB 1600 .....	288
4.6.8	Replacement of motor, axis 5, IRB 1600ID .....	294
4.6.9	Replacement of motor, axis 5, IRB 1660ID .....	302

4.6.10	Replacement of motor and timing belt, axis 6, IRB 1600 .....	311
4.6.11	Replacement of motor, axis 6, IRB 1600ID .....	315
4.6.12	Replacement of motor, axis 6, IRB 1660ID .....	319
4.7	Gearboxes .....	329
4.7.1	Replacement of gearbox, axes 1-2 .....	329
4.7.2	Service work on gearboxes, axes 3, 4, 5 and 6 .....	335
<b>5</b>	<b>Calibration</b> .....	<b>337</b>
5.1	Introduction to calibration .....	337
5.1.1	Introduction and calibration terminology .....	337
5.1.2	Calibration methods .....	338
5.1.3	When to calibrate .....	340
5.2	Synchronization marks and axis movement directions .....	341
5.2.1	Synchronization marks and synchronization position for axes .....	341
5.2.2	Calibration movement directions for all axes .....	344
5.3	Updating revolution counters .....	345
5.4	Calibrating with Axis Calibration method .....	349
5.4.1	Description of Axis Calibration .....	349
5.4.2	Calibration tools for Axis Calibration .....	352
5.4.3	Installation locations for the calibration tools .....	354
5.4.4	Axis Calibration - Running the calibration procedure .....	358
5.5	Calibrating with Calibration Pendulum method .....	366
5.6	Verifying the calibration .....	367
5.7	Checking the synchronization position .....	368
<b>6</b>	<b>Decommissioning</b> .....	<b>369</b>
6.1	Environmental information .....	369
6.2	Scrapping of robot .....	371
<b>7</b>	<b>Robot description</b> .....	<b>373</b>
7.1	Type A of IRB 1600 .....	373
7.2	Type A of IRB 1600ID .....	374
<b>8</b>	<b>Reference information</b> .....	<b>375</b>
8.1	Introduction .....	375
8.2	Applicable standards .....	376
8.3	Unit conversion .....	378
8.4	Screw joints .....	379
8.5	Weight specifications .....	382
8.6	Standard tools .....	383
8.7	Special tools .....	384
8.8	Lifting accessories and lifting instructions .....	386
<b>9</b>	<b>Spare part lists</b> .....	<b>387</b>
9.1	Spare part lists and illustrations .....	387
<b>10</b>	<b>Circuit diagram</b> .....	<b>389</b>
10.1	Circuit diagrams .....	389
<b>Index</b>		<b>391</b>

**This page is intentionally left blank**

# Overview of this manual

---

## About this manual

This manual contains instructions for:

- mechanical and electrical installation of the robot
- maintenance of the robot
- mechanical and electrical repair of the robot.

---

## Usage

This manual should be used during:

- installation, from lifting the robot to its work site and securing it to the foundation, to making it ready for operation
- maintenance work
- repair work and calibration.

---

## Who should read this manual?

This manual is intended for:

- installation personnel
- maintenance personnel
- repair personnel.

---

## Prerequisites

Maintenance/repair/installation personnel working with an ABB Robot must:

- be trained by ABB and have the required knowledge of mechanical and electrical installation/repair/maintenance work.

---

## Product manual scope

The manual covers covers all variants and designs of the IRB 1600/1660ID. Some variants and designs may have been removed from the business offer and are no longer available for purchase.

---

## Organization of chapters

The manual is organized in the following chapters:

Chapter	Contents
Safety, service	Safety information that must be read through before performing any installation or service work on robot. Contains general safety aspects as well as more specific information on how to avoid personal injuries and damage to the product.
Installation and commissioning	Required information about lifting and installation of the robot.
Maintenance	Step-by-step procedures that describe how to perform maintenance of the robot. Based on a maintenance schedule that may be used to plan periodical maintenance.
Repair	Step-by-step procedures that describe how to perform repair activities of the robot. Based on available spare parts.

*Continues on next page*

## Overview of this manual

Continued

Chapter	Contents
Calibration	Calibration procedures and general information about calibration.
Decommissioning	Environmental information about the robot and its components.
Reference information	Useful information when performing installation, maintenance or repair work. Includes lists of necessary tools, additional documents, safety standards, etc.
Spare parts and exploded views	Complete spare part list and complete list of robot components, shown in exploded views.
Circuit diagram	Reference to the circuit diagram for the robot.

## References

Documentation referred to in the manual, is listed in the table below.

Document name	Document ID
<i>Circuit diagram - IRB 1600/1660</i>	3HAC021351-003
<i>Product specification - IRB 1600/1660</i>	3HAC023604-001
<i>Product manual, spare parts - IRB 1600/1660</i>	3HAC049104-001
<i>Operating manual - General safety information <sup>i</sup></i>	3HAC031045-001
<i>Product manual - IRC5</i> IRC5 with main computer DSQC 639.	3HAC021313-001
<i>Product manual - IRC5</i> IRC5 with main computer DSQC1000.	3HAC047136-001
<i>Operating manual - IRC5 with FlexPendant</i>	3HAC050941-001
<i>Operating manual - Service Information System</i>	3HAC050944-001
<i>Operating manual - Calibration Pendulum</i>	3HAC16578-1
<i>Application manual - Additional axes and stand alone controller</i>	3HAC051016-001
<i>Application manual - CalibWare Field 5.0</i>	3HAC030421-001
<i>Technical reference manual - Lubrication in gearboxes</i>	3HAC042927-001
<i>Technical reference manual - System parameters</i>	3HAC050948-001
Instructions lifting accessory 3HAC024483-001	3HAC028664-002

<sup>i</sup> This manual contains all safety instructions from the product manuals for the manipulators and the controllers.

## Revisions

Revision	Description
-	First edition. See also <a href="#">Type A of IRB 1600 on page 373</a> .
A	AW equipped upper arm 1600ID, IRB 1600-6/1.2, IRB 1600-6/1.45, IRB 1600-8/1.2 and IRB 1600-8/1.45 added.
B	<i>Clean Room</i> added. Changes made in: <ul style="list-style-type: none"> <li>• <i>Prerequisites</i> in section <i>Overview</i></li> <li>• <i>Oil change</i> in section <i>Maintenance</i></li> </ul>
C	Content updated in section: <ul style="list-style-type: none"> <li>• <i>Making robot ready for operation, Clean Room / Additional installation procedure.</i></li> </ul>

Continues on next page

Revision	Description
D	<p>Content updated in chapter/section:</p> <ul style="list-style-type: none"> <li>• Maintenance/Cleaning of robot</li> <li>• Maintenance/Maintenance schedule: Interval for replacement of battery pack changed</li> <li>• Section <i>What is an emergency stop?</i> added to chapter Safety.</li> </ul>
E	<p>Content updated in chapter/section:</p> <ul style="list-style-type: none"> <li>• Maintenance/Oil in gearboxes: Amount of oil in gearboxes axes 1 and 2.</li> </ul>
F	<p>Content updated in sections:</p> <ul style="list-style-type: none"> <li>• New graphics for equipment load areas, see <a href="#">Fitting equipment on the robot (robot dimensions) on page 79</a>.</li> <li>• Instruction moved from chapter <i>Repair</i> to <i>Installation</i>, see <a href="#">Installation of the wire feeder shelf for 1600ID/1660ID on page 97</a>.</li> <li>• Spare part list, updated regarding <i>Foundry Plus Cable guard</i>.</li> <li>• <a href="#">Cleaning the IRB 1600/1660ID on page 149</a> in chapter Maintenance updated.</li> <li>• Sealing compound updated in <a href="#">Cut the paint or surface on the robot before replacing parts on page 159</a>.</li> <li>• Decommissioning chapter added.</li> </ul> <p>Updates in the chapter <i>Safety</i>:</p> <ul style="list-style-type: none"> <li>• Updated safety signal graphics for the levels <i>Danger</i> and <i>Warning</i>, see <a href="#">Safety signals in the manual on page 40</a>.</li> <li>• New safety labels on the manipulators, see <a href="#">Safety symbols on product labels on page 42</a>.</li> <li>• Revised terminology: <i>robot</i> replaced with <i>manipulator</i>.</li> </ul>
G	<p>Content updated in sections:</p> <ul style="list-style-type: none"> <li>• Added reference to lifting accessory, see <a href="#">Lifting and turning a suspended mounted robot on page 65</a>.</li> </ul>
H	<p>Content updated in sections:</p> <ul style="list-style-type: none"> <li>• Added note about not inserting guide pin too far into the tool flange, section <a href="#">Fitting equipment on the robot (robot dimensions) on page 79</a>.</li> <li>• Updated spare part numbers, in sections: Base, frame, upper arm, upper arm 1600ID and options.</li> <li>• New and updated safety symbols, see <a href="#">Safety symbols on product labels on page 42</a>.</li> </ul>

Revision	Description
J	<p>This revision includes the following updates:</p> <ul style="list-style-type: none"> <li>• A new block, about general illustrations, added in section <a href="#">How to read the product manual on page 17</a>.</li> <li>• Resolver connection added, connection for resolver signals axis 7 located on the base see section <a href="#">Customer connectors on the robot on page 116</a></li> <li>• Added an illustration that shows the directions of the robot stress forces and changed the value for the force in the Z plane, see <a href="#">Loads on foundation, robot on page 51</a>.</li> <li>• Improvements made in the instruction for replacing the complete ID upper arm, see <a href="#">Replacing the complete upper arm, IRB 1600ID/1660ID on page 188</a>.</li> <li>• Gearboxes and motor pinions from SAMP are added to the spare part lists together with a table that shows compability between the motors and gearboxes, see <a href="#">Spare parts -Compatible gearboxes and motors</a>. The spare part numbers are also removed from the Required equipment lists in the repair instructions for motors and gearboxes, and instead replaced with links to the Spare parts chapter.</li> <li>• The option <i>Foundry Plus Cable Guard</i> is removed.</li> <li>• Some general tightening torques have been changed/added, see updated values in <a href="#">Screw joints on page 379</a>.</li> <li>• Corrected value for working range of wall mounted robots, added working range for IRB 1600ID and updated a figure, see <a href="#">Working range on page 55</a>.</li> <li>• Spare part numbers for axis-4, axis-5 and axis-6 motors for IRB 1600ID are corrected.</li> <li>• Added <a href="#">Safety risks during handling of batteries on page 37</a>.</li> </ul>
K	<p>This revision includes the following updates:</p> <ul style="list-style-type: none"> <li>• Added range and capacity to the denomination of IRB 1600ID.</li> <li>• Added information about IRB 1600ID type A, on first inside page and as a new section <a href="#">Type A of IRB 1600ID on page 374</a>.</li> <li>• Spare part numbers for SAMP motors and upper arms are corrected, see <a href="#">Spare parts - Compatible gearboxes and motors</a>.</li> <li>• Added variants IRB 1600 - 10/1.2 and IRB 1600 - 10/1.45 to the manual.</li> <li>• Updated loads on the foundation, see <a href="#">Loads on foundation, robot on page 51</a>.</li> <li>• Corrected the appearance of figures in section <a href="#">Working range on page 55</a>.</li> <li>• Changed maximum tilt from 60° to 55°, see <a href="#">Requirements, foundation on page 52</a>.</li> <li>• All data about type of lubrication in gearboxes is moved from the manual to a separate lubrication manual, see <a href="#">Type and amount of oil in gearboxes on page 137</a>.</li> <li>• Added information about importance to install the robot with correct X direction in the base coordinate system, see <a href="#">Installation of additional mechanical stops on axis 1 on page 100</a> and <a href="#">Setting the system parameters for a suspended or tilted robot on page 72</a>.</li> <li>• A new SMB unit and battery is introduced, with longer battery lifetime.</li> <li>• Added mounting holes on the lower arm, see <a href="#">Fitting equipment on the robot (robot dimensions) on page 79</a>.</li> </ul>



Revision	Description
L	<p>This revision includes the following updates:</p> <ul style="list-style-type: none"> <li>• Spare numbers in general, updated/corrected.</li> <li>• Spare number for Motor axis 3 (Rexnord) changed.</li> <li>• Added information about risks when scrapping a decommissioned robot, see <a href="#">Scrapping of robot on page 371</a>.</li> <li>• Base connections, illustration updated with new views.</li> <li>• Updated tightening torque for the oil plug on axis 5-6 for IRB 1600ID, see <a href="#">Changing the oil in axes 5 and axis 5 and 6 gearboxes, IRB 1600ID/1660ID on page 141</a>.</li> <li>• <i>Spare parts and exploded views</i> are not included in this document but delivered as a separate document. See <i>Product manual, spare parts - IRB 1600/1660</i>.</li> <li>• Note about the placement of connectors in ID-upper arm added in Repair instructions. See <a href="#">Replacement of motor, axis 5, IRB 1600ID on page 294</a> and <a href="#">Replacing the wrist unit, IRB 1600ID on page 206</a>.</li> <li>• Note about handling the wrist during replacement added. See <a href="#">Replacing the wrist unit, IRB 1600ID on page 206</a>.</li> </ul>
M	<p>This revision includes the following updates:</p> <ul style="list-style-type: none"> <li>• Changed article number for signal lamp, see <a href="#">Installation of signal lamp for 1600 (option) on page 92</a>.</li> <li>• Added detailed view of the orientation of axis-5 motor, see Replacement of axis-5 motor.</li> <li>• Minor corrections.</li> </ul>
N	<p>This revision includes the following updates:</p> <ul style="list-style-type: none"> <li>• Added instructions for measuring the play in the ID wrist, see <a href="#">Measuring the play 1600ID/1660ID, axis 5 on page 233</a>, and <a href="#">Measuring the play 1600ID/1660ID, axis 6 on page 236</a>.</li> <li>• Minor corrections.</li> </ul>
P	<p>This revision includes the following updates:</p> <ul style="list-style-type: none"> <li>• Added a new variant IRB 1600ID - 6/1.55.</li> <li>• Updated the loads on foundation, see <a href="#">Loads on foundation, robot on page 51</a>.</li> <li>• Added maintenance activities for the grease oil in IRB 1600 axes 1 to 4.</li> </ul>
Q	<p>This revision includes the following updates:</p> <ul style="list-style-type: none"> <li>• Rename the new variant IRB 1600ID - 6/1.55 to IRB 1660ID - 6/1.55.</li> <li>• Updated figure that shows cable bracket and cable tie of axis-2 motor cable on the frame, see <a href="#">Replacement of motor, axis 2 on page 262</a>.</li> </ul>
R	<p>Published in release R16.2. The following updates are done in this revision:</p> <ul style="list-style-type: none"> <li>• Added a new variant IRB 1660ID - 4/1.55.</li> <li>• Wall mounting available to IRB 1660ID - X/1.55.</li> </ul>
S	<p>Published in release R17.1. The following updates are made in this revision:</p> <ul style="list-style-type: none"> <li>• Updated the robot weight, see <a href="#">Weight, robot on page 51</a>.</li> <li>• New standard calibration method is introduced (Axis Calibration). See <a href="#">Calibration on page 337</a>.</li> <li>• Information about grounding point is added, see <a href="#">Robot cabling and connection points on page 119</a>.</li> </ul>

Continues on next page

Revision	Description
T	<p>Published in release R17.2. The following updates are made in this revision:</p> <ul style="list-style-type: none"> <li>• Information about coupled axes in <a href="#">Updating revolution counters on page 345</a>.</li> <li>• Caution about removing metal residues added in sections about SMB boards.</li> <li>• Information added into calibration procedure regarding installation of calibration tool on turning disc, see <a href="#">Overview of the calibration procedure on the FlexPendant on page 358</a>.</li> <li>• Information about minimum resonance frequency added.</li> <li>• Bending radius for static floor cables added.</li> <li>• Updated list of applicable standards.</li> <li>• Article number for the Calibration tool box, Axis Calibration is changed.</li> <li>• Section <a href="#">Start of robot in cold environments on page 126</a> added.</li> <li>• Updated information regarding replacement of brake release board.</li> <li>• Updated information regarding lifting tool, upper arm, in section <a href="#">Special tools on page 384</a>.</li> <li>• Updated information regarding disconnecting and reconnecting battery cable to serial measurement board.</li> </ul>
U	<p>Published in release R18.1. The following updates are made in this revision:</p> <ul style="list-style-type: none"> <li>• Information added about fatigue to Axis Calibration tool, see <a href="#">Calibration tools for Axis Calibration on page 352</a>.</li> <li>• Added sections in <a href="#">General procedures on page 154</a>.</li> <li>• Safety restructured.</li> <li>• Updated spare part number brake release unit (was DSQC574, is DSQC1054)</li> <li>• Tool flange figure is updated.</li> <li>• Note added to calibration chapter to emphasize the requirement of equally dressed robot when using previously created reference calibration values.</li> <li>• Information about myABB Business Portal added.</li> <li>• Added Nickel in environmental information.</li> </ul>
V	<p>Published in release R18.2. The following updates are done in this revision:</p> <ul style="list-style-type: none"> <li>• Updated information of holes for mounting of extra equipment for IRB 1600, see <a href="#">Holes for mounting of extra equipment for IRB 1600 on page 84</a>.</li> <li>• Added section for inspection of labels in maintenance chapter.</li> <li>• Updated information regarding o-ring replacement for axis-1 and axis-2 motors.</li> </ul>
W	<p>Published in release R18.2. The following updates are done in this revision:</p> <ul style="list-style-type: none"> <li>• Updated reference.</li> </ul>

# Product documentation

---

## Categories for user documentation from ABB Robotics

The user documentation from ABB Robotics is divided into a number of categories. This listing is based on the type of information in the documents, regardless of whether the products are standard or optional.

All documents can be found via myABB Business Portal, [www.myportal.abb.com](http://www.myportal.abb.com).

---

## Product manuals

Manipulators, controllers, DressPack/SpotPack, and most other hardware is delivered with a **Product manual** that generally contains:

- Safety information.
  - Installation and commissioning (descriptions of mechanical installation or electrical connections).
  - Maintenance (descriptions of all required preventive maintenance procedures including intervals and expected life time of parts).
  - Repair (descriptions of all recommended repair procedures including spare parts).
  - Calibration.
  - Decommissioning.
  - Reference information (safety standards, unit conversions, screw joints, lists of tools).
  - Spare parts list with corresponding figures (or references to separate spare parts lists).
  - References to circuit diagrams.
- 

## Technical reference manuals

The technical reference manuals describe reference information for robotics products, for example lubrication, the RAPID language, and system parameters.

---

## Application manuals

Specific applications (for example software or hardware options) are described in **Application manuals**. An application manual can describe one or several applications.

An application manual generally contains information about:

- The purpose of the application (what it does and when it is useful).
- What is included (for example cables, I/O boards, RAPID instructions, system parameters, software).
- How to install included or required hardware.
- How to use the application.
- Examples of how to use the application.

*Continues on next page*

---

### Operating manuals

The operating manuals describe hands-on handling of the products. The manuals are aimed at those having first-hand operational contact with the product, that is production cell operators, programmers, and troubleshooters.

# How to read the product manual

## Reading the procedures

The procedures contain references to figures, tools, material, and so on. The references are read as described below.

### References to figures

The procedures often include references to components or attachment points located on the manipulator/controller. The components or attachment points are marked with *italic text* in the procedures and completed with a reference to the figure where the current component or attachment point is shown.

The denomination in the procedure for the component or attachment point corresponds to the denomination in the referenced figure.

The table below shows an example of a reference to a figure from a step in a procedure.

	Action	Note/Illustration
8.	Remove the <i>rear attachment screws, gearbox</i> .	Shown in the figure <a href="#">Location of gearbox on page xx</a> .

### References to required equipment

The procedures often include references to equipment (spare parts, tools, etc.) required for the different actions in the procedure. The equipment is marked with *italic text* in the procedures and completed with a reference to the section where the equipment is listed with further information, that is article number and dimensions.

The designation in the procedure for the component or attachment point corresponds to the designation in the referenced list.

The table below shows an example of a reference to a list of required equipment from a step in a procedure.

	Action	Note/Illustration
3.	Fit a new <i>sealing, axis 2</i> to the gearbox.	Art. no. is specified in <a href="#">Required equipment on page xx</a> .

## Safety information

The manual includes a separate safety chapter that must be read through before proceeding with any service or installation procedures. All procedures also include specific safety information when dangerous steps are to be performed.

Read more in the chapter [Safety on page 19](#).

## Illustrations

The robot is illustrated with general figures that does not take painting or protection type in consideration.

Likewise, certain work methods or general information that is valid for several robot models, can be illustrated with illustrations that show a different robot model than the one that is described in the current manual.

**This page is intentionally left blank**

---

# 1 Safety

## 1.1 General safety information

### 1.1.1 Limitation of liability

---

#### Limitation of liability

Any information given in this manual regarding safety must not be construed as a warranty by ABB that the industrial robot will not cause injury or damage even if all safety instructions are complied with.

The information does not cover how to design, install and operate a complete system, nor does it cover all peripheral equipment that can influence the safety of the entire system.

In particular, liability cannot be accepted if injury/damage has been caused for any of the following reasons:

- Use of the robot in other ways than intended.
- Incorrect operation or maintenance.
- Operation of the robot when the safety devices are defective, not in their intended location or in any other way not working.
- When instructions for operation and maintenance are not followed.
- Non-authorized design modifications made in or around the robot.
- Repairs carried out by in-experienced or non-qualified personnel.
- Foreign objects.
- Force majeure.

---

#### Nation/region specific regulations

To protect personnel, the complete system must be designed and installed in accordance with the safety requirements set forth in the standards and regulations of the country where the robot is installed.

---

#### To be observed by the supplier of the complete system

The integrator is responsible that the safety devices necessary to protect people working with the robot system are designed and installed correctly.

When integrating the robot with external devices and machines:

- The supplier of the complete system must ensure that all circuits used in the safety function are interlocked in accordance with the applicable standards for that function.
- The supplier of the complete system must ensure that all circuits used in the emergency stop function are interlocked in a safe manner, in accordance with the applicable standards for the emergency stop function.

*Continues on next page*

# 1 Safety

---

## 1.1.1 Limitation of liability

*Continued*

The integrator of the final application is required to perform an assessment of the hazards and risks (HRA).



### Note

The integrator is responsible for the safety of the final application.

### Safe access

The robot system shall be designed to allow safe access to all areas where intervention is necessary during operation, adjustment, and maintenance.

Where it is necessary to perform tasks within the safeguarded space there shall be safe and adequate access to the task locations.

Safety zones, which must be crossed before admittance, must be set up in front of the robot's working space. Light beams or sensitive mats are suitable devices.

Turntables or the like should be used to keep the operator out of the robot's working space.

A safety fence is recommended to ensure safeguarded space. Sufficient space must be provided around the manipulator to protect those working with or on it from hazards such as crushing.

The fence or enclosure must be dimensioned to withstand the force created if the load being handled by the robot is dropped or released at maximum speed.

Determine the maximum speed from the maximum velocities of the robot axes and from the position at which the robot is working in the work cell (see the section *Robot motion* in the *Product specification*).

Also consider the maximum possible impact caused by a breaking or malfunctioning rotating tool or other device fitted to the robot.

### Safe handling

Users shall not be exposed to hazards, including slipping, tripping, and falling hazards.

It must be possible to safely turn off tools, such as milling cutters, etc. Make sure that guards remain closed until the cutters stop rotating.

It should be possible to release parts by manual operation (valves).

### Safe design

Emergency stop buttons must be positioned in easily accessible places so that the robot can be stopped quickly. If any of the buttons do not stop all the robot workcell motion, each emergency stop button must be marked, if more than one is provided, to indicate its designated safety function.

Grippers/end effectors must be designed so that they do not drop work pieces/tools in the event of a power failure or a disturbance to the controller.

Unauthorized modifications of the originally delivered robot are prohibited. Without the consent of ABB, it is forbidden to attach additional parts through welding, riveting, or drilling of new holes into the castings. The strength of the robot could be affected.



### 1.1.2 Protective stop and emergency stop

---

#### Overview

The protective stops and emergency stops are described in the product manual for the controller.

# 1 Safety

---

## 1.2.1 Fire extinguishing

## 1.2 Safety actions

### 1.2.1 Fire extinguishing



#### Note

Use a CARBON DIOXIDE (CO<sub>2</sub>) extinguisher in the event of a fire in the manipulator or controller.

### 1.2.2 Emergency release of the robot axes

#### Description

In an emergency situation, the brakes on a robot axis can be released manually by pushing a brake release button.

How to release the brakes is described in the section:

- [Manually releasing the brakes on page 66](#).

The robot may be moved manually on smaller robot models, but larger models may require using an overhead crane or similar equipment.

#### Increased injury

Before releasing the brakes, make sure that the weight of the robot does not increase the pressure on the trapped person, further increasing any injury.



#### **DANGER**

When releasing the holding brakes, the robot axes may move very quickly and sometimes in unexpected ways.

Make sure no personnel is near or beneath the robot.

# 1 Safety

---

## 1.2.3 Make sure that the main power has been switched off

### 1.2.3 Make sure that the main power has been switched off

---

#### Description

Working with high voltage is potentially lethal. Persons subjected to high voltage may suffer cardiac arrest, burn injuries, or other severe injuries. To avoid these personal injuries, switch off the main power on the controller before proceeding work.



#### Note

Switch off all main power switches in a MultiMove system.

## **1.3 Safety risks**

### **1.3.1 Safety risks during installation and service work on robots**

---

#### **Requirements on personnel**

Only persons who know the robot and are trained in the operation and handling of the robot are allowed to maintain the robot. Persons who are under the influence of alcohol, drugs or any other intoxicating substances are not allowed to install, maintain, repair, or use the robot.

- Those in charge of operations must make sure that safety instructions are available for the installation in question.
- Those who install or service/maintain the robot must have the appropriate training for the equipment in question and in any safety matters associated with it.
- Personnel should be trained on responding to emergency or abnormal situations.

---

#### **General risks during installation and service**

The instructions in the product manual must always be followed.

Never turn the power on to the robot before it is properly fixed and bolted to its foundation/support.

Make sure that no one else can turn on the power to the controller and robot while you are working with the system. A good method is to always lock the main switch on the controller cabinet with a safety lock.

Make sure that no one else can turn on the power to the controller and robot while you are working with the system. A good method is to remove the power cable to the controller.

If the robot is installed at a height, hanging, or other than standing directly on the floor, there may be additional risks than those for a robot standing directly on the floor.

Energy stored in the robot for the purpose of counterbalancing certain axes may be released if the robot, or parts thereof, are dismantled.

Never use the robot as a ladder, which means, do not climb on the controller, motors, or other parts during service work. There is a risk of slipping because of the high temperature of the motors and oil spills that can occur on the robot. There is also a risk of the robot being damaged.

To avoid damaging the product, make sure that there are no loose screws, turnings, or other parts inside the product after work has been performed.

---

#### **Safety risks during operational disturbances**

Corrective maintenance must only be carried out by qualified personnel who are familiar with the entire installation as well as the special risks associated with its different parts.

*Continues on next page*

# 1 Safety

---

## 1.3.1 Safety risks during installation and service work on robots

*Continued*

If the working process is interrupted, extra care must be taken due to risks other than those associated with regular operation. Such an interruption may have to be rectified manually.

---

### **Spare parts and special equipment**

ABB does not supply spare parts and special equipment which have not been tested and approved by ABB. The installation and/or use of such products could negatively affect the structural properties of the robot and as a result of that affect the active or passive safety operation. ABB is not liable for damages caused by the use of non-original spare parts and special equipment. ABB is not liable for damages or injuries caused by unauthorized modifications to the robot.

---

### **Connection of external safety devices**

Apart from the built-in safety functions, the robot is also supplied with an interface for the connection of external safety devices. An external safety function can interact with other machines and peripheral equipment via this interface. This means that control signals can act on safety signals received from the peripheral equipment as well as from the robot.

---

### **Personal protective equipment**

Always use suitable personal protective equipment, based on the risk assessment for the installation.

---

### **Allergenic material**

See [Environmental information on page 369](#) for specification of allergenic materials in the product, if any.

---

## 1.3.2 Moving robots are potentially lethal

### Description

Any moving robot is a potentially lethal machine.

When running, the robot may perform unexpected and sometimes irrational movements. Moreover, all movements are performed with great force and may seriously injure any personnel and/or damage any piece of equipment located within the working range of the robot.

### Safe handling

	Action	Note
1	Before attempting to run the robot, make sure all emergency stop equipment is correctly installed and connected.	Emergency stop equipment such as gates, tread mats, light curtains, etc.
2	Usually the hold-to-run function is active only in manual full speed mode. To increase safety it is also possible to activate hold-to-run for manual reduced speed with a system parameter. The hold-to-run function is used in manual mode, not in automatic mode.	How to use the hold-to-run function is described in section <i>How to use the hold-to-run function</i> in the <i>Operating manual - IRC5 with FlexPendant</i> .
3	Make sure no personnel are present within the working range of the robot before pressing the start button.	

# 1 Safety

---

## 1.3.3 First test run may cause injury or damage

### 1.3.3 First test run may cause injury or damage

---

#### Description

After installation and performing service activities, there are several safety risks to take into consideration before the first test run.

---

#### Safe handling

Use this procedure when performing the first test run after installation, maintenance, or repair.



#### **DANGER**

Running the robot without fulfilling the following aspects, may involve a risk of injury and cause severe damage to the robot.

	Action
1	Remove all tools and foreign objects from the robot and its working area.
2	Verify that the robot is properly secured to its position by all screws, before it is powered up.
3	Verify that any safety equipment installed to secure the position or restrict the robot motion during service activity is removed.
4	Verify that the fixture and work piece are well secured, if applicable.
5	Install all safety equipment properly.
6	Make sure all personnel are standing at a safe distance from the robot, and is out of its reach behind safety fences, or similar.
7	If maintenance or repair has been done, pay special attention to the function of the part that was serviced.

#### Collision risks



#### **CAUTION**

When programming the movements of the robot, always identify potential collision risks before the first test run.



### 1.3.4 Work inside the working range of the robot



#### WARNING

If work must be carried out within the work area of the robot, then the following points must be observed:

- The operating mode selector on the controller must be in the manual mode position to render the three-position enabling device operational and to block operation from a computer link or remote control panel.
- The maximum speed of the robot is limited to 250 mm/s when the operating mode selector is in the position *Manual mode with reduced speed*. This should be the normal position when entering the working space.

The position *Manual mode with full speed (100%)* may only be used by trained personnel who are aware of the risks that this entails. *Manual mode with full speed (100%)* is not available in USA or Canada.

- Pay attention to the rotating axes of the robot. Keep away from axes to not get entangled with hair or clothing. Also, be aware of any danger that may be caused by rotating tools or other devices mounted on the robot or inside the cell.
- Keep clear of moving parts so that limbs, hands, or fingers do not get trapped or crushed by the robot.
- To prevent anyone else from taking control of the robot, always put a safety lock on the cell door and bring the three-position enabling device with you when entering the working space.



#### WARNING

**NEVER**, under any circumstances, stay beneath any of the robot's axes! There is always a risk that the robot will move unexpectedly when robot axes are moved using the three-position enabling device or during other work inside the working range of the robot.

### 1.3.5 Enabling device and hold-to-run functionality

---

#### Three-position enabling device

The three-position enabling device is a manually operated, constant pressure push-button which, when continuously activated in one position only, allows potentially hazardous functions but does not initiate them. In any other position, hazardous functions are stopped safely.

The three-position enabling device is of a specific type where you must press the push-button only half-way to activate it. In the fully in and fully out positions, operating the robot is impossible.



#### Note

The three-position enabling device is a push-button located on the teach pendant which, when pressed halfway in, switches the system to MOTORS ON. When the enabling device is released or pushed all the way in, the manipulator switches to the MOTORS OFF state.

To ensure safe use of the teach pendant, the following must be implemented:

- The enabling device must never be rendered inoperational in any way.
- During programming and testing, the enabling device must be released as soon as there is no need for the robot to move.
- Anyone entering the working space of the robot must always hold the teach pendant. This is to prevent anyone else from taking control of the robot without his/her knowledge.

#### Hold-to-run function

The hold-to-run function allows movement when a button connected to the function is actuated manually and immediately stops any movement when released. The hold-to-run function can only be used in manual mode.

How to operate the hold-to-run function for IRC5 is described in *Operating manual - IRC5 with FlexPendant*.

---

### 1.3.6 Risks associated with live electric parts

---

#### Voltage related risks, general

Work on the electrical equipment of the robot must be performed by a qualified electrician in accordance with electrical regulations.

Although troubleshooting may, on occasion, need to be carried out while the power supply is turned on, the robot must be turned off (by setting the main switch to OFF) when repairing faults, disconnecting electric leads, and disconnecting or connecting units.

The main supply to the robot must be connected in such a way that it can be turned off from outside the working space of the robot.

Make sure that no one else can turn on the power to the controller and robot while you are working with the system. A good method is to always lock the main switch on the controller cabinet with a safety lock.

The necessary protection for the electrical equipment and robot during installation, commissioning, and maintenance is guaranteed if the valid regulations are followed.

---

#### Voltage related risks, IRC5 controller

A danger of high voltage is associated with, for example, the following parts:

- Be aware of stored electrical energy (DC link, Ultracapacitor bank unit) in the controller.
- Units such as I/O modules, can be supplied with power from an external source.
- The main supply/main switch
- The transformers
- The power unit
- The control power supply (230 VAC)
- The rectifier unit (262/400-480 VAC and 400/700 VDC. Note: capacitors!)
- The drive unit (400/700 VDC)
- The drive system power supply (230 VAC)
- The service outlets (115/230 VAC)
- The customer power supply (230 VAC)
- The power supply unit for additional tools, or special power supply units for the machining process.
- The external voltage connected to the controller remains live even when the robot is disconnected from the mains.
- Additional connections.

---

#### Voltage related risks, manipulator

A danger of low voltage is associated with the manipulator in:

- The power supply for the motors (up to 800 VDC).
- The user connections for tools or other parts of the installation (max. 230 VAC).

*Continues on next page*

# 1 Safety

---

## 1.3.6 Risks associated with live electric parts

*Continued*

---

### **Voltage related risks, tools, material handling devices, etc.**

Tools, material handling devices, etc., may be live even if the robot system is in the OFF position. Power supply cables which are in motion during the working process may be damaged.

### 1.3.7 The unit is sensitive to ESD

#### Description

ESD (electrostatic discharge) is the transfer of electrical static charge between two bodies at different potentials, either through direct contact or through an induced electrical field. When handling parts or their containers, personnel not grounded may potentially transfer high static charges. This discharge may destroy sensitive electronics.

#### Safe handling

	Action	Note
1	Use a wrist strap. The wrist strap button is located inside the controller.	Wrist straps must be tested frequently to ensure that they are not damaged and are operating correctly. <ul style="list-style-type: none"> <li>• <i>Product manual - IRC5</i></li> <li>• <i>Product manual - IRC5 Compact</i></li> <li>• <i>Product manual - IRC5 Panel Mounted Controller</i></li> </ul>
2	Use an ESD protective floor mat.	The mat must be grounded through a current-limiting resistor.
3	Use a dissipative table mat.	The mat should provide a controlled discharge of static voltages and must be grounded.

# 1 Safety

---

## 1.3.8 Hot parts may cause burns

### 1.3.8 Hot parts may cause burns

---

#### Description

During normal operation, many parts become hot. Touching these may cause burns.

There is also a risk of fire if flammable materials are put on hot surfaces.

---

#### Safe handling

Always use your hand, at some distance, to feel if heat is radiating from the potentially hot component before actually touching it.

Wait until the potentially hot component has cooled if it is to be removed or handled in any other way.

Do not put anything on hot metal surfaces, e.g. paper or plastic.

### 1.3.9 Safety risks related to pneumatic/hydraulic systems

#### General

Special safety regulations apply to pneumatic and hydraulic systems.



#### Note

All components that remain pressurized after separating the machine from the power supply must be provided with clearly visible drain facilities and a warning sign that indicates the need for pressure relief before adjustments or performing any maintenance on the robot system.

#### Residual energy

Residual energy can be present in these systems. After shutdown, particular care must be taken.

The pressure must be released in the complete pneumatic or hydraulic systems before starting to repair them.

Work on hydraulic equipment may only be performed by persons with special knowledge and experience of hydraulics.

All pipes, hoses, and connections have to be inspected regularly for leaks and damage. Damage must be repaired immediately.

Splashed oil may cause injury or fire.

#### Safe design

Gravity may cause any parts or objects held by these systems to drop.

Dump valves should be used in case of emergency.

Shot bolts should be used to prevent tools, etc., from falling due to gravity.

# 1 Safety

---

## 1.3.10 Brake testing

### 1.3.10 Brake testing

---

#### When to test

During operation, the holding brake of each axis normally wears down. A test can be performed to determine whether the brake can still perform its function.

---

#### How to test

The function of the holding brake of each axis motor may be verified as described below:

- 1 Run each robot axis to a position where the combined weight of the robot arm and any load is maximized (maximum static load).
- 2 Switch the motor to the MOTORS OFF.
- 3 Inspect and verify that the axis maintains its position.

If the robot does not change position as the motors are switched off, then the brake function is adequate.



### 1.3.11 Safety risks during handling of batteries

---

#### Description

Under normal conditions of use, the electrode materials and liquid electrolyte in the batteries are not exposed to the outside, provided the battery integrity is maintained and seals remain intact.

There is a risk of exposure only in case of abuse (mechanical, thermal, electrical) which leads to the activation of safety valves and/or the rupture of the battery container. Electrolyte leakage, electrode materials reaction with moisture/water or battery vent/explosion/fire may follow, depending upon the circumstances.

**Note**

Appropriate disposal regulations must be observed.

---

#### Safe handling

Use safety glasses when handling the batteries.

In the event of leakage, wear rubber gloves and chemical apron.

In the event of fire, use self-contained breathing apparatus.

Do not short circuit, recharge, puncture, incinerate, crush, immerse, force discharge or expose to temperatures above the declared operating temperature range of the product. Risk of fire or explosion.

Operating temperatures are listed in [Pre-installation procedure on page 50](#).

# 1 Safety

## 1.3.12 Safety risks during work with gearbox lubricants (oil or grease)

### 1.3.12 Safety risks during work with gearbox lubricants (oil or grease)

#### Description

When handling gearbox lubricants, there is a risk of both personal injury and product damage occurring. The following safety information must be regarded before performing any work with lubricants in the gearboxes.



#### Note

When handling oil, grease, or other chemical substances the safety information of the manufacturer must be observed.



#### Note

When aggressive media is handled, an appropriate skin protection must be provided. Gloves and goggles are recommended.



#### Note



Appropriate disposal regulations must be observed.



#### Note

Take special care when handling hot lubricants.





#### Safe handling

Warning	Description	Elimination/Action
 <b>Hot oil or grease</b>	Changing and draining gearbox oil or grease may require handling hot lubricant heated up to 90 °C.	Make sure that protective gear like goggles and gloves are always worn during this activity.
 <b>Allergic reaction</b>	When working with gearbox lubricant there is a risk of an allergic reaction.	Make sure that protective gear like goggles and gloves are always worn.
 <b>Possible pressure build-up in gearbox</b>	When opening the oil or grease plug, there may be pressure present in the gearbox, causing lubricant to spray from the opening.	Open the plug carefully and keep away from the opening. Do not overfill the gearbox when filling.

Continues on next page

## 1.3.12 Safety risks during work with gearbox lubricants (oil or grease)

*Continued*

Warning	Description	Elimination/Action
 <p><b>Do not overfill</b></p>	<p>Overfilling of gearbox lubricant can lead to internal over-pressure inside the gearbox which in turn may:</p> <ul style="list-style-type: none"> <li>• damage seals and gaskets</li> <li>• completely press out seals and gaskets</li> <li>• prevent the robot from moving freely.</li> </ul>	<p>Make sure not to overfill the gearbox when filling it with oil or grease.</p> <p>After filling, verify that the level is correct.</p>
 <p><b>Do not mix types of oil</b></p>	<p>Mixing types of oil may cause severe damage to the gearbox.</p>	<p>When filling gearbox oil, do not mix different types of oil unless specified in the instructions. Always use the type of oil specified by the manufacturer.</p>
 <p><b>Heat up the oil</b></p>	<p>Warm oil drains quicker than cold oil.</p>	<p>When changing gearbox oil, first run the robot for a time to heat up the oil.</p>
 <p><b>Specified amount depends on drained volume</b></p>	<p>The specified amount of oil or grease is based on the total volume of the gearbox. When changing the lubricant, the amount refilled may differ from the specified amount, depending on how much has previously been drained from the gearbox.</p>	<p>After filling, verify that the level is correct.</p>
 <p><b>Contaminated oil in gear boxes</b></p>	<p>When draining the oil make sure that as much oil as possible is drained from the gearbox. The reason for this is to drain as much oil sludge and metal chips as possible from the gearbox. The magnetic oil plugs will take care of any remaining metal chips.</p>	

# 1 Safety

## 1.4.1 Safety signals in the manual

## 1.4 Safety signals and symbols

### 1.4.1 Safety signals in the manual





#### Introduction to safety signals

This section specifies all safety signals used in the user manuals. Each signal consists of:



- A caption specifying the danger level (DANGER, WARNING, or CAUTION) and the type of danger.
- A brief description of what will happen if the the danger is not eliminated.
- Instruction about how to eliminate danger to simplify doing the work.

#### Danger levels

The table below defines the captions specifying the danger levels used throughout this manual.

Symbol	Designation	Significance
	DANGER	Warns that an accident <i>will</i> occur if the instructions are not followed, resulting in a serious or fatal injury and/or severe damage to the product. It applies to warnings that apply to danger with, for example, contact with high voltage electrical units, explosion or fire risk, risk of poisonous gases, risk of crushing, impact, fall from height, and so on.
	WARNING	Warns that an accident <i>may</i> occur if the instructions are not followed that can lead to serious injury, possibly fatal, and/or great damage to the product. It applies to warnings that apply to danger with, for example, contact with high voltage electrical units, explosion or fire risk, risk of poisonous gases, risk of crushing, impact, fall from height, etc.
	ELECTRICAL SHOCK	Warns for electrical hazards which could result in severe personal injury or death.
	CAUTION	Warns that an accident may occur if the instructions are not followed that can result in injury and/or damage to the product. It also applies to warnings of risks that include burns, eye injury, skin injury, hearing damage, crushing or slipping, tripping, impact, fall from height, etc. Furthermore, it applies to warnings that include function requirements when fitting and removing equipment where there is a risk of damaging the product or causing a breakdown.
	ELECTROSTATIC DISCHARGE (ESD)	Warns for electrostatic hazards which could result in severe damage to the product.

Continues on next page

Symbol	Designation	Significance
	NOTE	Describes important facts and conditions.
	TIP	Describes where to find additional information or how to do an operation in an easier way.

# 1 Safety

## 1.4.2 Safety symbols on product labels

### 1.4.2 Safety symbols on product labels

#### Introduction to labels

This section describes safety symbols used on labels (stickers) on the product. Symbols are used in combinations on the labels, describing each specific warning. The descriptions in this section are generic, the labels can contain additional information such as values.



#### Note

The safety and health symbols on the labels on the product must be observed. Additional safety information given by the system builder or integrator must also be observed.



#### Types of labels

Both the manipulator and the controller are marked with several safety and information labels, containing important information about the product. The information is useful for all personnel handling the robot, for example during installation, service, or operation.



The safety labels are language independent, they only use graphics. See [Symbols on safety labels on page 42](#).

The information labels can contain information in text (English, German, and French).

#### Symbols on safety labels

Symbol	Description
 xx0900000812	<b>Warning!</b> Warns that an accident <i>may</i> occur if the instructions are not followed that can lead to serious injury, possibly fatal, and/or great damage to the product. It applies to warnings that apply to danger with, for example, contact with high voltage electrical units, explosion or fire risk, risk of poisonous gases, risk of crushing, impact, fall from height, etc.
 xx0900000811	<b>Caution!</b> Warns that an accident may occur if the instructions are not followed that can result in injury and/or damage to the product. It also applies to warnings of risks that include burns, eye injury, skin injury, hearing damage, crushing or slipping, tripping, impact, fall from height, etc. Furthermore, it applies to warnings that include function requirements when fitting and removing equipment where there is a risk of damaging the product or causing a breakdown.
 xx0900000839	<b>Prohibition</b> Used in combinations with other symbols.

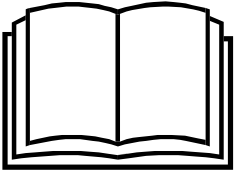
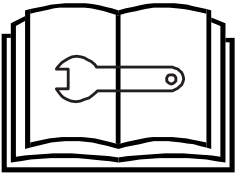
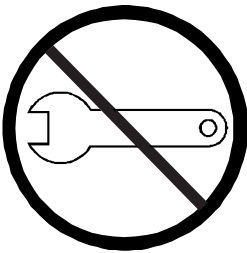
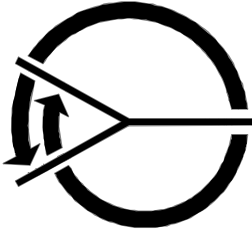



*Continues on next page*

Symbol	Description
 <p>xx0900000813</p>	<p><b>See user documentation</b>            Read user documentation for details.            Which manual to read is defined by the symbol:</p> <ul style="list-style-type: none"> <li>• No text: <i>Product manual</i>.</li> <li>• EPS: <i>Application manual - Electronic Position Switches</i>.</li> </ul>
 <p>xx0900000816</p>	<p><b>Before disassemble, see product manual</b></p>
 <p>xx0900000815</p>	<p><b>Do not disassemble</b>            Disassembling this part can cause injury.</p>
 <p>xx0900000814</p>	<p><b>Extended rotation</b>            This axis has extended rotation (working area) compared to standard.</p>
 <p>xx0900000808</p>	<p><b>Brake release</b>            Pressing this button will release the brakes. This means that the robot arm can fall down.</p>

# 1 Safety

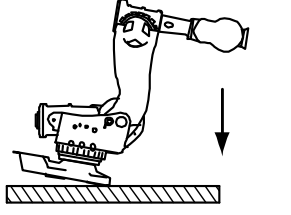
## 1.4.2 Safety symbols on product labels

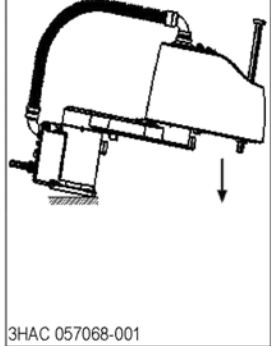
Continued

Symbol	Description
 <p>xx0900000810</p>   <p>3HAC 057068-001</p> <p>xx1500002402</p>	<p><b>Tip risk when loosening bolts</b> The robot can tip over if the bolts are not securely fastened.</p>
 <p>xx0900000817</p>	<p><b>Crush</b> Risk of crush injuries.</p>

Continues on next page



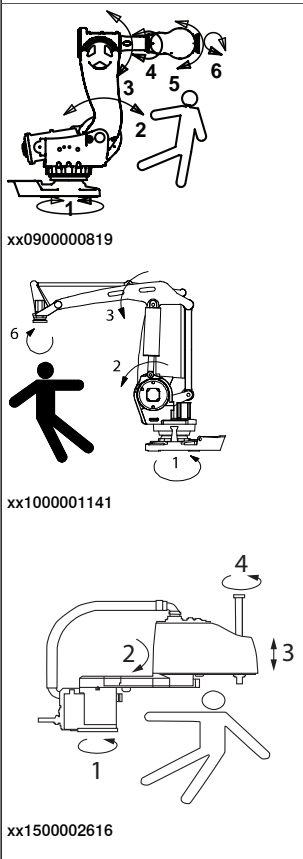





Symbol	Description
 <p>xx0900000818</p> <p>xx1300001087</p>	<p><b>Heat</b> Risk of heat that can cause burns. (Both signs are used)</p>
 <p>xx0900000819</p> <p>xx1000001141</p> <p>xx1500002616</p>	<p><b>Moving robot</b> The robot can move unexpectedly.</p>

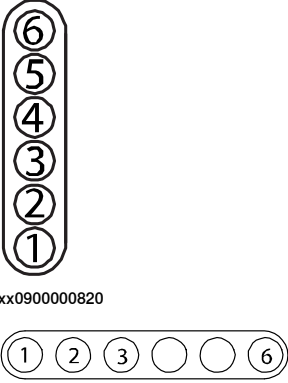

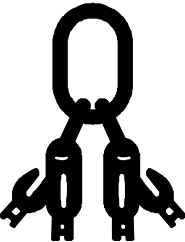

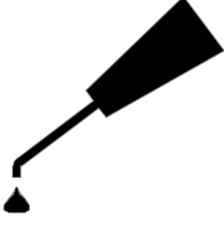
# 1 Safety

## 1.4.2 Safety symbols on product labels

Continued

Symbol	Description
 <p>xx0900000820</p> <p>xx1000001140</p>	<b>Brake release buttons</b>
 <p>xx0900000821</p>	<b>Lifting bolt</b>
 <p>xx1000001242</p>	<b>Chain sling with shortener</b>
 <p>xx0900000822</p>	<b>Lifting of robot</b>
 <p>xx0900000823</p>	<b>Oil</b> Can be used in combination with prohibition if oil is not allowed.
 <p>xx0900000824</p>	<b>Mechanical stop</b>

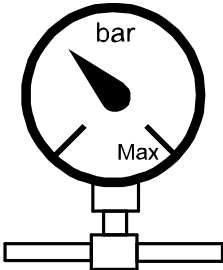
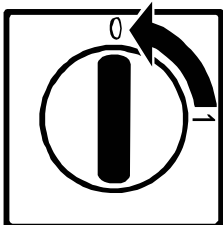
Continues on next page

Symbol	Description
 <p>xx1000001144</p>	<p><b>No mechanical stop</b></p>
 <p>xx0900000825</p>	<p><b>Stored energy</b> Warns that this part contains stored energy. Used in combination with <i>Do not disassemble</i> symbol.</p>
 <p>xx0900000826</p>	<p><b>Pressure</b> Warns that this part is pressurized. Usually contains additional text with the pressure level.</p>
 <p>xx0900000827</p>	<p><b>Shut off with handle</b> Use the power switch on the controller.</p>
 <p>xx1400002648</p>	<p><b>Do not step</b> Warns that stepping on these parts can cause damage to the parts.</p>

**This page is intentionally left blank**

## 2 Installation and commissioning

### 2.1 Introduction

---

#### General

This chapter contains assembly instructions and information for installing the IRB 1600/1660ID at the working site.

More detailed technical data can be found in the *Product specification* for the IRB 1600/1660ID, such as:

- Load diagram
- Permitted extra loads (equipment), if any
- Location of extra loads (equipment), if any.

---

#### Safety information

Before any installation work is commenced, it is extremely important that all safety information is observed.

There are general safety aspects that must be read through, as well as more specific safety information that describes the danger and safety risks when performing the procedures. Read the chapter [Safety on page 19](#) before performing any installation work.



#### Note

If the IRB 1600/1660ID is connected to power, always make sure that the robot is connected to protective earth before starting any installation work.

For more information see:

- *Product manual - IRC5*

## 2 Installation and commissioning

### 2.2.1 Pre-installation procedure

## 2.2 Unpacking

### 2.2.1 Pre-installation procedure

#### Introduction

This section is intended for use when unpacking and installing the robot for the first time. It also contains information useful during later re-installation of the robot.

#### Prerequisites for installation personnel

Installation personnel working with an ABB product must:

- be trained by ABB and have the required knowledge of mechanical and electrical installation/maintenance/repair work
- conform to all national and local codes.

#### Checking the pre-requisites for installation

	Action
1	Make a visual inspection of the packaging and make sure that nothing is damaged.
2	Remove the packaging.
3	Check for any visible transport damage.  <b>Note</b> Stop unpacking and contact ABB if transport damages are found.
4	Clean the unit with a lint-free cloth, if necessary.
5	Make sure that the lifting accessory used (if required) is suitable to handle the weight of the robot as specified in: <a href="#">Weight, robot on page 51</a>
6	If the robot is not installed directly, it must be stored as described in: <a href="#">Storage conditions, robot on page 53</a>
7	Make sure that the expected operating environment of the robot conforms to the specifications as described in: <a href="#">Operating conditions, robot on page 53</a>
8	Before taking the robot to its installation site, make sure that the site conforms to: <ul style="list-style-type: none"><li>• <a href="#">Loads on foundation, robot on page 51</a></li><li>• <a href="#">Protection classes, robot on page 54</a></li><li>• <a href="#">Requirements, foundation on page 52</a></li></ul>
9	Before moving the robot, please observe the stability of the robot: <a href="#">Risk of tipping/stability on page 61</a>
10	When these prerequisites are met, the robot can be taken to its installation site as described in section: <a href="#">On-site installation on page 63</a>
11	Install required equipment, if any. <ul style="list-style-type: none"><li>• <a href="#">Installation of signal lamp for 1600 (option) on page 92</a></li></ul>

*Continues on next page*

### Weight, robot

The table shows the weight of the robot.

Robot model	Weight
IRB 1600/1660ID	IRB 1600/IRB 1600ID: 250 kg IRB 1660ID: 260 kg



#### Note

The weight does not include tools and other equipment fitted on the robot.

### Loads on foundation, robot

The illustration shows the directions of the robots stress forces.

The directions are valid for all floor mounted, suspended and inverted robots.

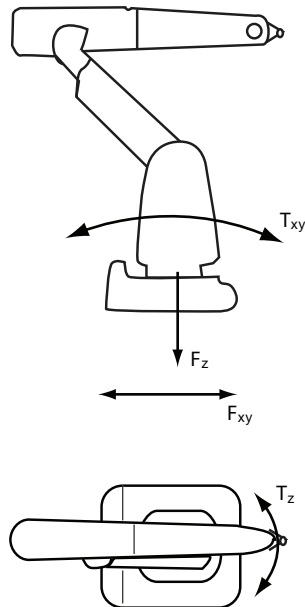

xx110000521

$F_{xy}$	Force in any direction in the XY plane
$F_z$	Force in the Z plane
$T_{xy}$	Bending torque in any direction in the XY plane
$T_z$	Bending torque in the Z plane

The table shows the various forces and torques working on the robot during different kinds of operation.



#### Note

These forces and torques are extreme values that are rarely encountered during operation. The values also never reach their maximum at the same time!

Continues on next page

## 2 Installation and commissioning

### 2.2.1 Pre-installation procedure

Continued



#### WARNING

The robot installation is restricted to the mounting options given in following load table(s).

#### Floor mounted

Force	Endurance load (in operation)	Max. load (emergency stop)
Force xy	± 1850 N	± 3900 N
Force z	- 2700 ± 1150 N	- 2700 ± 2200 N
Torque xy	± 1750 Nm	± 4000 Nm
Torque z	± 855 Nm	± 1500 Nm

#### Wall mounted

Force	Endurance load (in operation)	Max. load (emergency stop)
Force xy	± 3900 N	± 5300 N
Force z	± 1400 N	± 2800 N
Torque xy	± 2310 Nm	± 3850 Nm
Torque z	± 855 Nm	± 1550 Nm

#### Suspended

Force	Endurance load (in operation)	Max. load (emergency stop)
Force xy	± 1850 N	± 3900 N
Force z	+ 2700 ± 1150 N	+ 2700 ± 2200 N
Torque xy	± 1750 Nm	± 4000 Nm
Torque z	± 855 Nm	± 1500 Nm

### Requirements, foundation

The table shows the requirements for the foundation where the weight of the installed robot is included:

Requirement	Value	Note
Flatness of foundation surface	0.5 mm	Flat foundations give better repeatability of the resolver calibration compared to original settings on delivery from ABB. The value for levelness aims at the circumstance of the anchoring points in the robot base. In order to compensate for an uneven surface, the robot can be recalibrated during installation. If resolver/encoder calibration is changed this will influence the absolute accuracy.
Maximum tilt	55°	The limit for the maximum payload on the robot is reduced if the robot is tilted from 0°. Contact ABB for further information about acceptable loads.

Continues on next page



Requirement	Value	Note
Minimum resonance frequency	25 Hz  <b>Note</b> It may affect the manipulator life-time to have a lower resonance frequency than recommended.	The value is recommended for optimal performance. Due to foundation stiffness, consider robot mass including equipment. <sup>i</sup> For information about compensating for foundation flexibility, see <i>Application manual - Controller software IRC5</i> , section <i>Motion Process Mode</i> .

<sup>i</sup> The minimum resonance frequency given should be interpreted as the frequency of the robot mass/inertia, robot assumed stiff, when a foundation translational/torsional elasticity is added, i.e., the stiffness of the pedestal where the robot is mounted. The minimum resonance frequency should not be interpreted as the resonance frequency of the building, floor etc. For example, if the equivalent mass of the floor is very high, it will not affect robot movement, even if the frequency is well below the stated 25 Hz. The robot should be mounted as rigid as possible to the floor.

Disturbances from other machinery will affect the robot and the tool accuracy. The robot has resonance frequencies in the region 10 – 20 Hz and disturbances in this region will be amplified, although somewhat damped by the servo control. This might be a problem, depending on the requirements from the applications. If this is a problem, the robot needs to be isolated from the environment.

#### Storage conditions, robot

The table shows the allowed storage conditions for the robot:

Parameter	Value
Minimum ambient temperature	-25° C
Maximum ambient temperature	+55° C
Maximum ambient temperature (less than 24 hrs)	+70° C
Maximum ambient humidity	95% at constant temperature (gaseous only)



#### Note

If the manipulator should not be used immediately, all unpainted/unprotected surfaces must be treated with a rust inhibitor, type Vaseline or similar.

#### Operating conditions, robot

The table shows the allowed operating conditions for the robot:

Parameter	Value
Minimum ambient temperature	+5° C
Maximum ambient temperature	+45° C
Maximum ambient humidity	Max. 95% at constant temperature

*Continues on next page*

## 2 Installation and commissioning

---

### 2.2.1 Pre-installation procedure

*Continued*

---

#### Protection classes, robot

The table shows the available protection types of the robot, with the corresponding protection class.

Protection type	Protection class
Manipulator, protection type Standard	IRB 1600: IP 54 IRB 1600ID: IP 40 IRB 1660ID: IP 40 (Wrist: IP 67)
Manipulator, protection type Foundry Plus	IP 67
Manipulator, protection type Clean Room	IP 54
Manipulator, protection type Wash	IP 67

## 2.2.2 Working range

## Range of movement - IRB 1600

Axis	Type of motion	Range of movement 1.2 m reach	Range of movement 1.45 m reach
1	Rotation motion	+180° to -180° <sup>i</sup>	+180° to -180° <sup>i</sup>
2	Arm motion	+110° to -63° +136° to -63° (with axis 1 limited to ±100°)	+120° to -90° +150° to -90° (with axis 1 limited to ±95°)
3	Arm motion	+55° to -235°	+65° to -245°
4	Rotation motion	+200° to -200° default +190 rev. <sup>ii</sup> to -190 rev. maximum <sup>iii</sup>	+200° to -200° default +190 rev. <sup>ii</sup> to -190 rev. maximum <sup>iii</sup>
5	Bend motion	+115° to -115°	+115° to -115°
6	Turn motion	+400° to -400° default +288 rev. <sup>ii</sup> to -288 rev. maximum <sup>iii</sup>	+400° to -400° default +288 rev. <sup>ii</sup> to -288 rev. maximum <sup>iii</sup>

<sup>i</sup> The working range of axis 1 has the following limitations for wall mounted robots:

- IRB 1600-6/x: ± 20°
- IRB 1600-10/x: ± 60°

If the robot is tilted, the following combinations of tilt angles and axis 1 working ranges are allowed:

- IRB 1600-6/x: axis 1 ± 45° with tilt angles up to 30°
- IRB 1600-10/x: axis 1 ± 180° with tilt angles up to 55°

<sup>ii</sup> rev. = Revolutions

<sup>iii</sup> The default working range for axis 4 and axis 6 can be extended by changing parameter values in the software.

Option 610-1 "Independent axis" can be used for resetting the revolution counter after the axis has been rotated (no need for "rewinding" the axis).

## Range of movement - IRB 1600ID

Axis	Type of motion	Range of movement 1.5 m reach
1	Rotation motion	+180° to -180° <sup>i</sup>
2	Arm motion	+150° to -90°
3	Arm motion	+79° to -238°
4	Rotation motion	+155° to -155°
5	Bend motion	+135° to -90°
6	Turn motion	+200° to -200° +288 rev. <sup>ii</sup> to -288 rev. maximum <sup>iii</sup>

<sup>i</sup> If the robot is tilted, the working range with tilt angles is:

- ± 40° with tilt angles up to 30°

<sup>ii</sup> rev. = Revolutions

<sup>iii</sup> The default working range for axis 6 can be extended by changing parameter values in the software. Option 610-1 "Independent axis" can be used for resetting the revolution counter after the axis has been rotated (no need for "rewinding" the axis).

## Range of movement - IRB 1660ID

Axis	Type of motion	Range of movement 1.55 m reach
1	Rotation motion	+180° to -180° <sup>i</sup>

*Continues on next page*

## 2 Installation and commissioning

### 2.2.2 Working range

Continued

Axis	Type of motion	Range of movement 1.55 m reach
2	Arm motion	+150° to -90°
3	Arm motion	+79° to -238°
4	Rotation motion	+175° to -175°
5	Bend motion	+120° to -120°
6	Turn motion	+400° to -400° +191 rev. <sup>ii</sup> to -191 rev. maximum <sup>iii</sup>

i The working range of axis 1 has the following limitations for wall mounted robots:

- IRB 1660ID-X/1.55:  $\pm 45^\circ$

If the robot is tilted, the working range with tilt angles is:

- $\pm 180^\circ$  with tilt angles up to  $45^\circ$

ii rev. = Revolutions

iii The default working range for axis 6 can be extended by changing parameter values in the software. Option 610-1 "Independent axis" can be used for resetting the revolution counter after the axis has been rotated (no need for "rewinding" the axis).

### Positions at wrist center 1.2 m reach

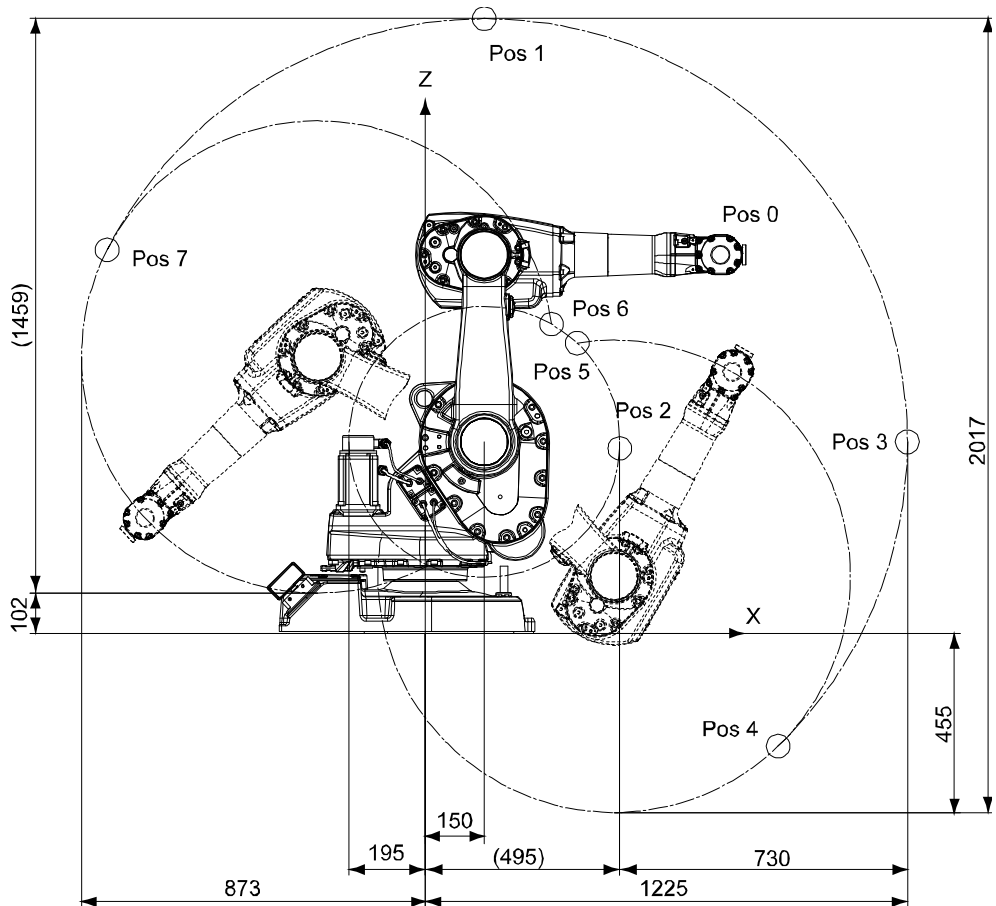

xx100000914

Position	X (mm)	Z (mm)	Axis 2 angle (degrees)	Axis 3 angle (degrees)
0	750	962	0	0
1	150	1562	0	-90

Continues on next page

## 2 Installation and commissioning

### 2.2.2 Working range

*Continued*

Position	X (mm)	Z (mm)	Axis 2 angle (degrees)	Axis 3 angle (degrees)
2	494	470	0	+55
3	1225	487	+90	-90
4	897	-287	+136	-90
5	386	737	+136	-235
6	321	786	-63	+55
7	-808	975	-63	-90

#### Positions at wrist center 1.45 m reach

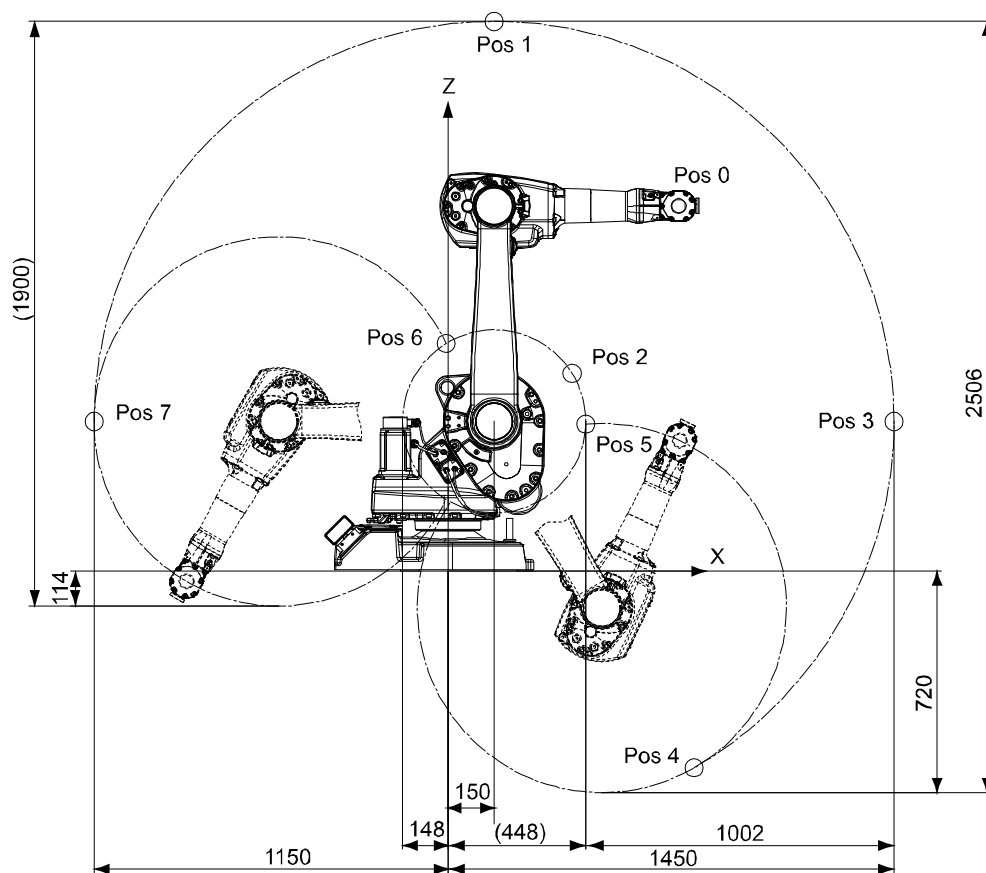

xx1000000915

Position	X (mm)	Z (mm)	Axis 2 angle (degrees)	Axis 3 angle (degrees)
0	750	1187	0	0
1	150	1787	0	-90
2	404	643	0	+65
3	1450	487	+90	-90
4	800	-639	+150	-90
5	448	478	+150	-245
6	-6	740	-90	+65

*Continues on next page*

## 2 Installation and commissioning

### 2.2.2 Working range

Continued

Position	X (mm)	Z (mm)	Axis 2 angle (degrees)	Axis 3 angle (degrees)
7	-1150	487	-90	-90

### Positions at wrist center IRB 1600ID

IRB 1600ID-4/1.5

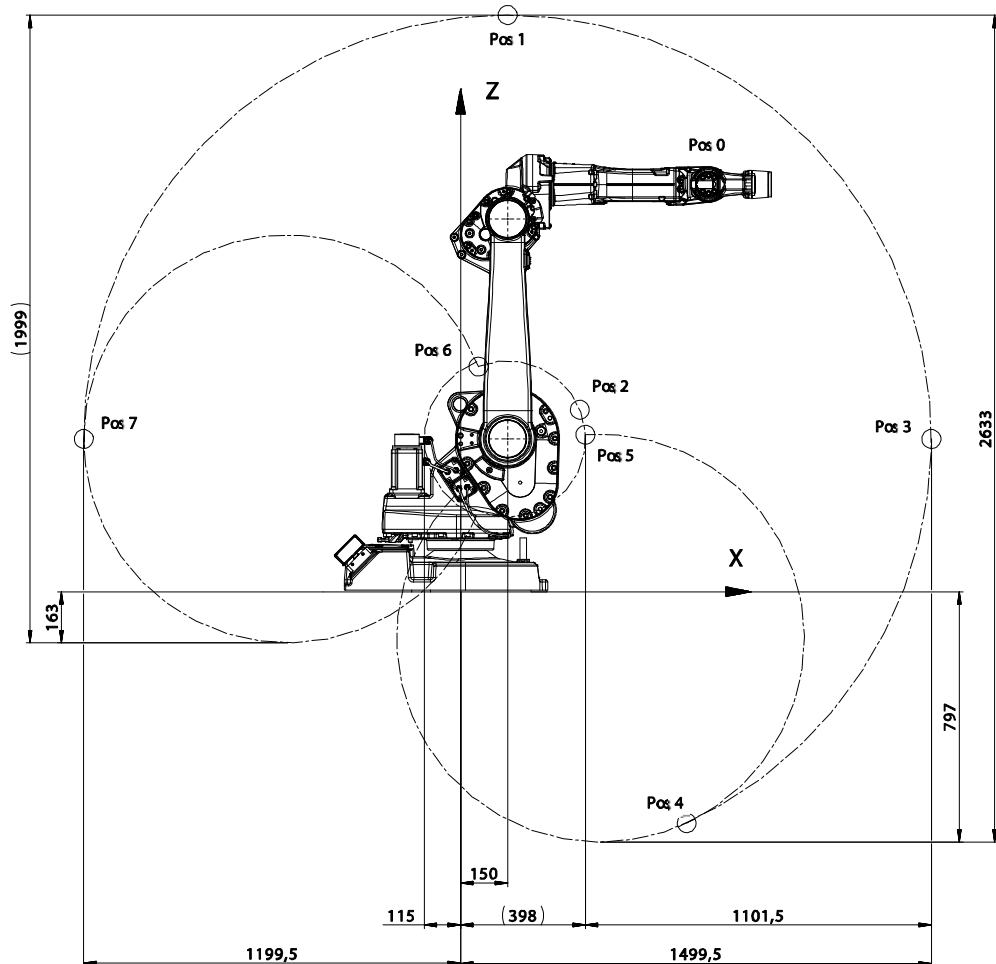

xx0700000136

Position	X (mm)	Z (mm)	Axis 2 angle (degrees)	Axis 3 angle (degrees)
0	790	1297	0	0
1	150	1836	0	-80
2	380	579	0	+79
3	1500	487	+90	-80
4	721	-737	+150	-80
5	398	500	+150	-238
6	58	717	-90	+79
7	-1200	487	-90	-80

Continues on next page

#### Positions at wrist center IRB 1660ID

IRB 1660ID-X/1.55

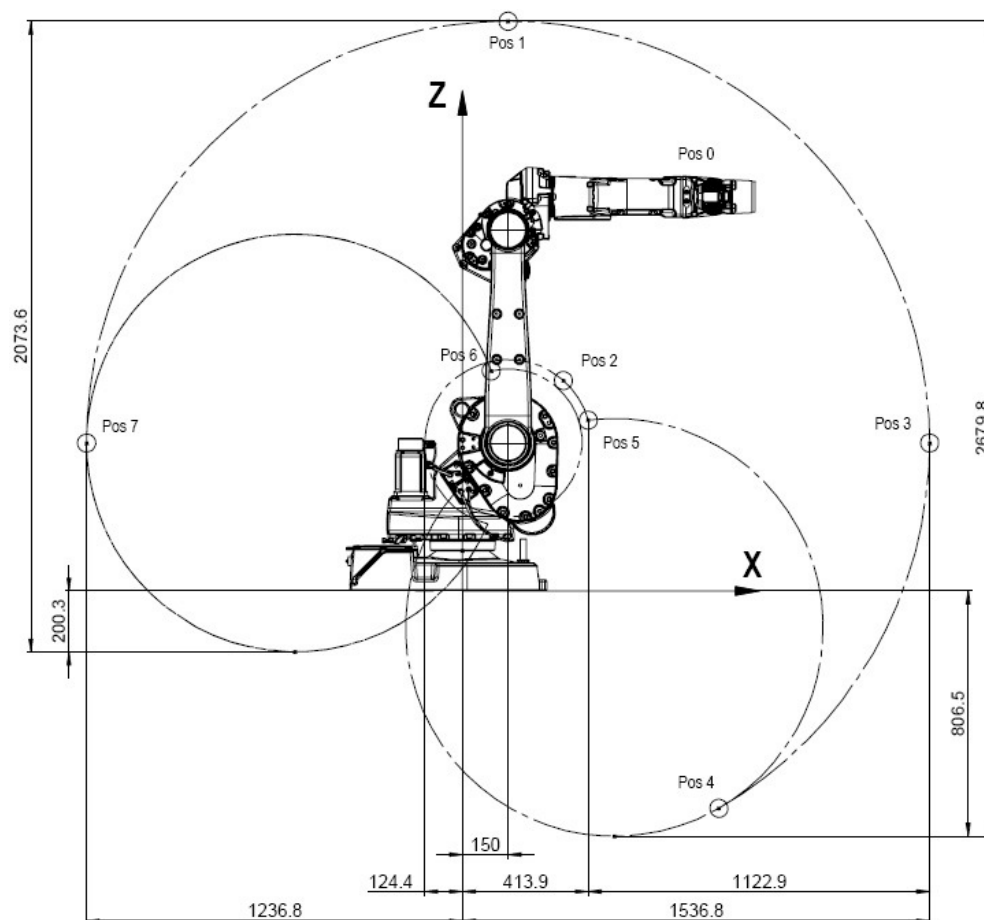

xx1500001246

Position	X (mm)	Z (mm)	Axis 2 angle (degrees)	Axis 3 angle (degrees)
0	828	1,296.5	0	0
1	150	1,873.3	0	-81
2	332.2	691.7	0	+79
3	1,536.8	486.5	+90	-81
4	843.4	-714.5	+150	-81
5	413.9	561.7	+150	-238
6	94.6	723.7	-90	+79
7	-1,236.8	486.5	-90	-81

*Continues on next page*

## 2 Installation and commissioning

### 2.2.2 Working range

Continued

#### Turning radius

The turning radius for the robot is shown in the figure below. Notice the differences depending on the length of the lower arm.

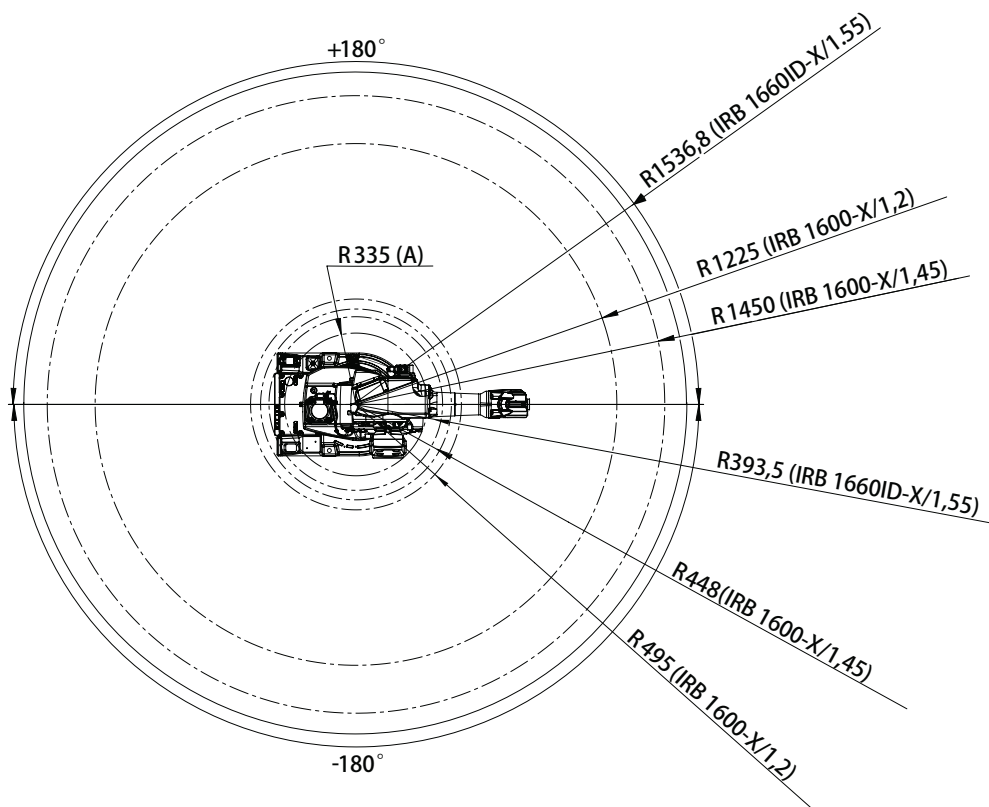

xx1500002817

(A)	Minimum turning radius axis 1 (all models)
-----	--



### 2.2.3 Risk of tipping/stability

#### Risk of tipping

If the robot is not fastened to the foundation while moving the arm, the robot is not stable in the whole working area. Moving the arm will displace the center of gravity, which may cause the robot to tip over.

The shipping position is the most stable position.

**Do not change the robot position before securing it to the foundation!**

#### Shipping and transportation position

This figure shows the robot in its shipping position and transportation position.

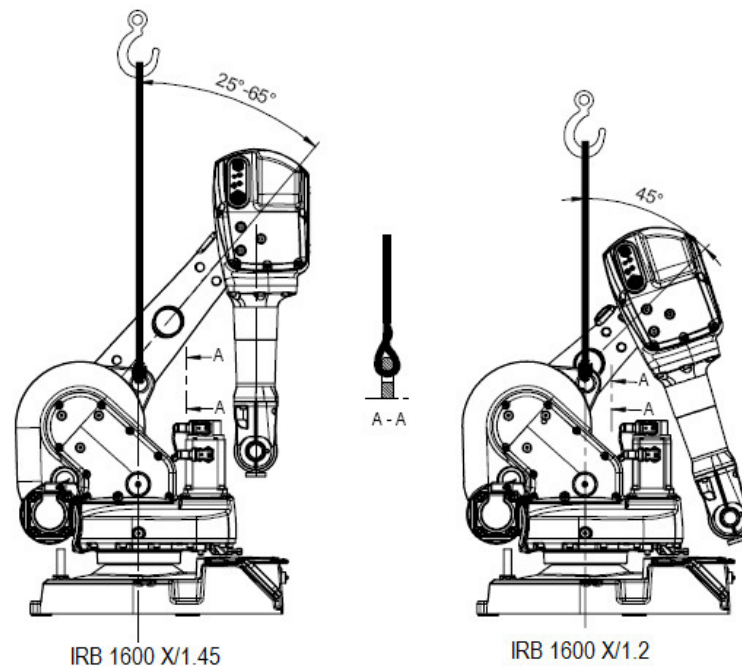

xx1500001247

*Continues on next page*

## 2 Installation and commissioning

### 2.2.3 Risk of tipping/stability

Continued

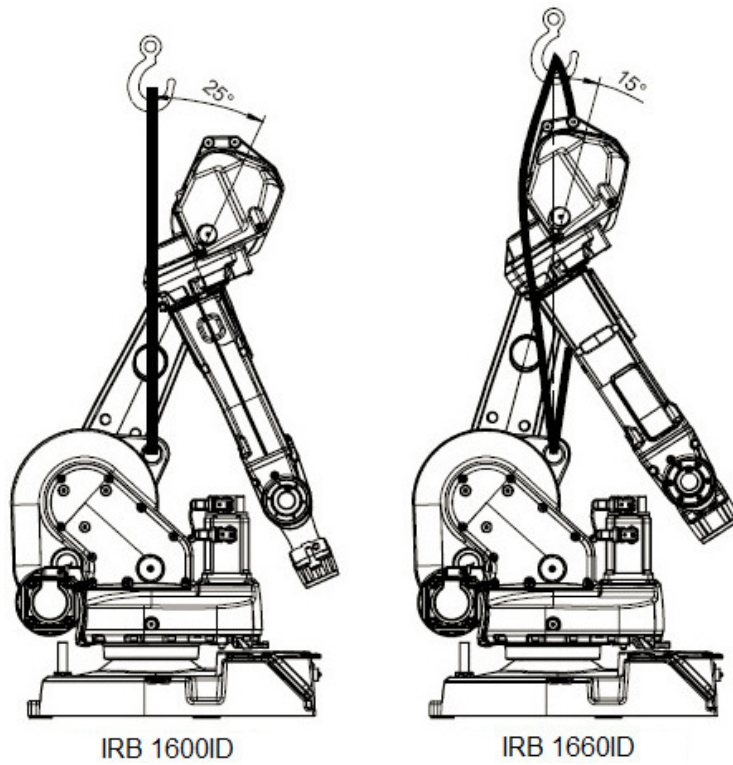

xx1500001248



#### WARNING

The robot is likely to be mechanically unstable if not secured to the foundation.

## 2.3 On-site installation

### 2.3.1 Lifting robot with roundslings

#### Attaching the roundslings

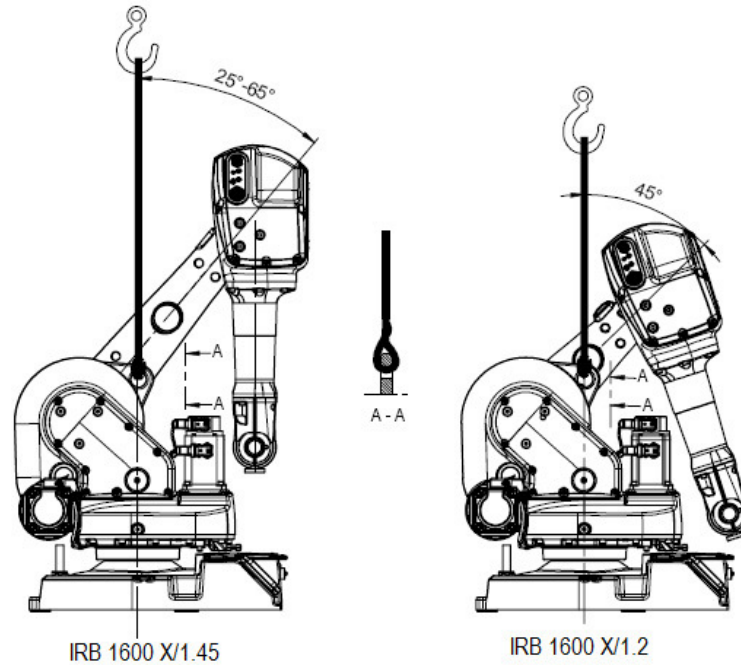

xx1500001247

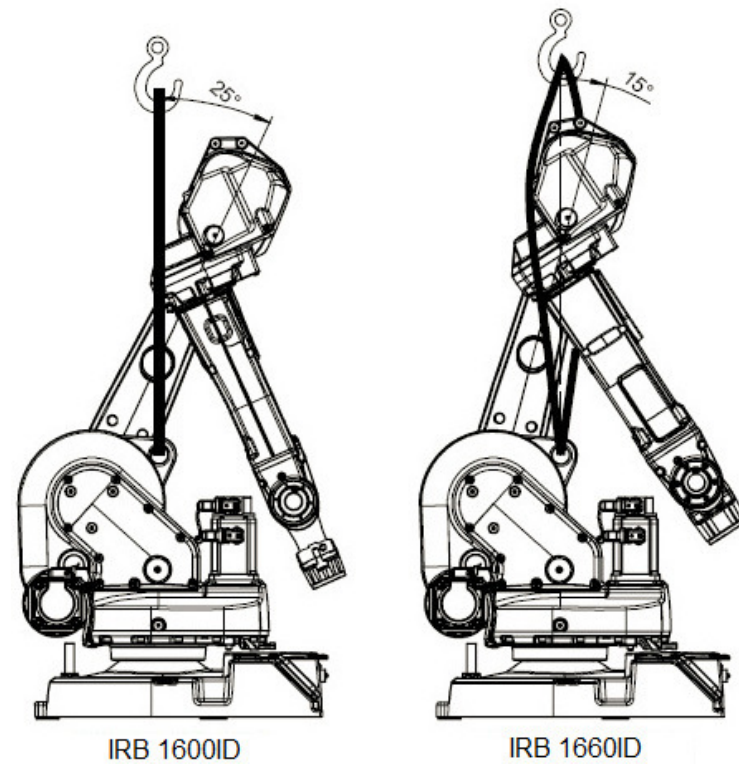

xx1500001248

*Continues on next page*

## 2 Installation and commissioning

### 2.3.1 Lifting robot with roundslings



Continued

#### Required equipment

Equipment	Art. no.	Note
Overhead crane	-	Lifting capacity: 500 kg.
Roundsling	-	Length: 2 m. Lifting capacity: 500 kg.

#### Lifting the robot with roundslings

Use this procedure to lift the robot with roundslings.

	Action	Note
1	Move the robot to an appropriate lifting position.	See <a href="#">Risk of tipping/stability on page 61</a> .
2	Secure the <i>roundsling</i> safely at the lifting lug in the frame and at the overhead crane.	Make sure the roundsling has free space and does not wear against any part of the robot. Capacity for the roundsling is specified in <a href="#">Required equipment on page 64</a> . See attachment in <a href="#">Attaching the roundslings on page 63</a> .
3	 <b>CAUTION</b> The robot weighs IRB 1600/IRB 1600ID: 250 kg IRB 1660ID: 260 kg All lifting accessories used must be sized accordingly!	
4	 <b>WARNING</b> Personnel must not, under any circumstances, be present under the suspended load!	
5	Raise the overhead crane to lift the robot.	

### 2.3.2 Lifting and turning a suspended mounted robot

#### Introduction

How to lift and turn the robot into a suspended position using turning accessory 3HAC037108-001 is described in the lifting instruction (article number 3HAC028664-002) delivered with the turning accessory. Contact ABB for more information.

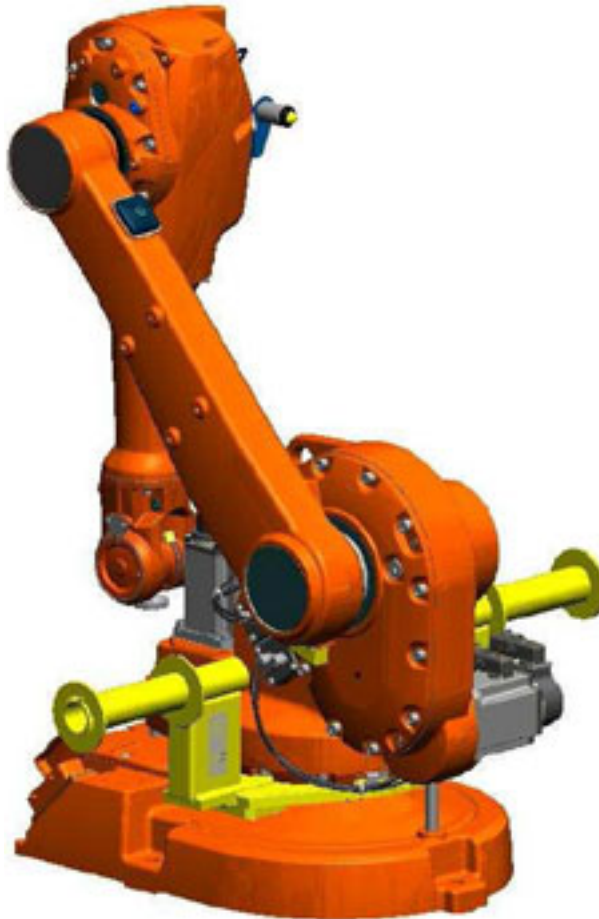

xx100000320

## 2 Installation and commissioning

### 2.3.3 Manually releasing the brakes

### 2.3.3 Manually releasing the brakes

#### General



The section below details how to release the holding brakes of each axis' motor.

This may be done in one of three ways:

- using the brake release unit when the robot is connected to the controller.
- using the brake release unit when the robot is disconnected from the controller, but connected to an external power supply at the connector R1.MP.
- using an external voltage supply directly on the motor connector.

#### Using the brake release unit when the robot is connected to the controller

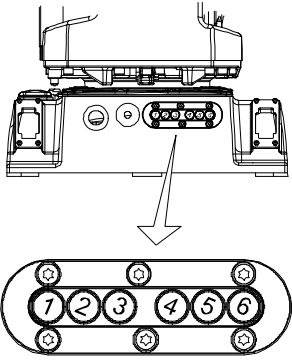
Use this procedure to release the holding brakes with the internal brake release unit.

	Action	Note
1	The internal brake release unit is located at the base of the robot and equipped with six buttons for controlling the axes brakes. The buttons are numbered according to the numbers of the axes.	 xx0400001255
2	 <b>DANGER</b> When releasing the holding brakes, the robot axes may move very quickly and sometimes in unexpected ways! Make sure no personnel is near or beneath the robot arm!	
3	Release the holding brake on a particular robot axis by pressing the corresponding button on the internal brake release panel and keeping it depressed. The brake will function again as soon as the button is released.	

*Continues on next page*

#### Using the brake release unit with an external power supply

This section details how to release the holding brakes with the internal brake release unit using an external voltage supply. This is done if the robot is not connected to the controller.

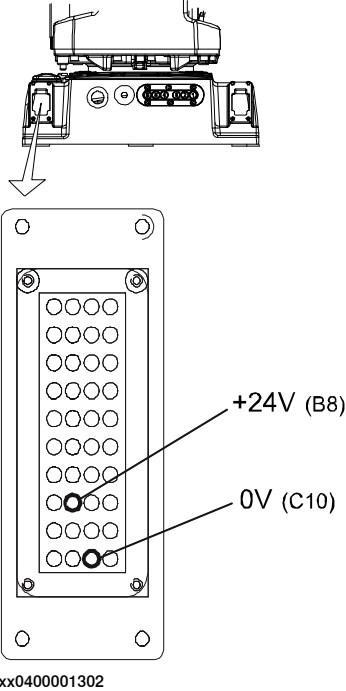
	Action	Note
1	 <p><b>DANGER</b></p> <p>Incorrect connections, such as supplying power to the wrong pin, may cause all brakes to be released simultaneously!</p>	<p>Also, be careful not to interchange the 24V and 0V pins. If they are mixed up, damage can be caused to a resistor diode and to the system board.</p>
2	<p>Connect an external power supply to connector R1.MP.</p>	 <p>xx0400001302</p> <p>Supply:</p> <ul style="list-style-type: none"> <li>• 0V on pin C10</li> <li>• 24V on pin B8</li> </ul>
3	<p>Push the brake release button to release the holding brakes, according to the previous procedure.</p>	

## 2 Installation and commissioning

### 2.3.4 Orienting and securing the robot

### 2.3.4 Orienting and securing the robot

#### General

This section details how to orient and secure the robot at a horizontal level at the installation site.

#### Hole configuration, base

The figure shows the hole pattern and dimensions of the robot base.

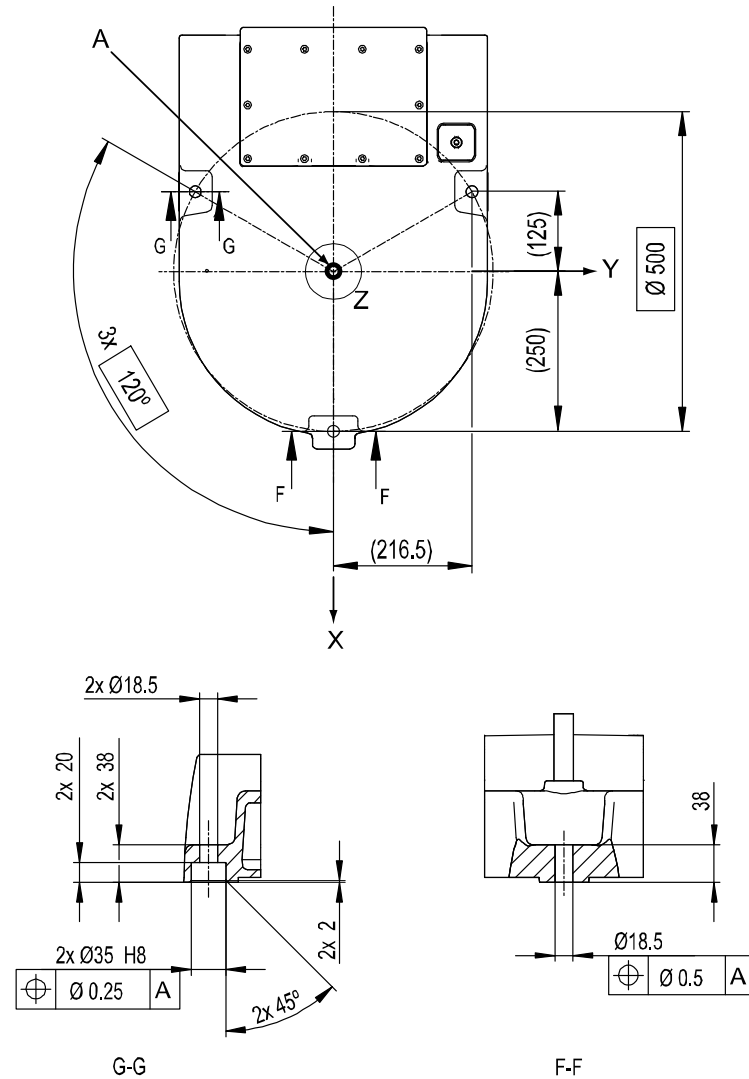

A	Center of axis 1
---	------------------

Continues on next page



## 2 Installation and commissioning

### 2.3.4 Orienting and securing the robot

*Continued*

#### Dimension, mounting surface and guiding sleeve

The figure shows the dimension of the mounting surface and guiding sleeves, if used.

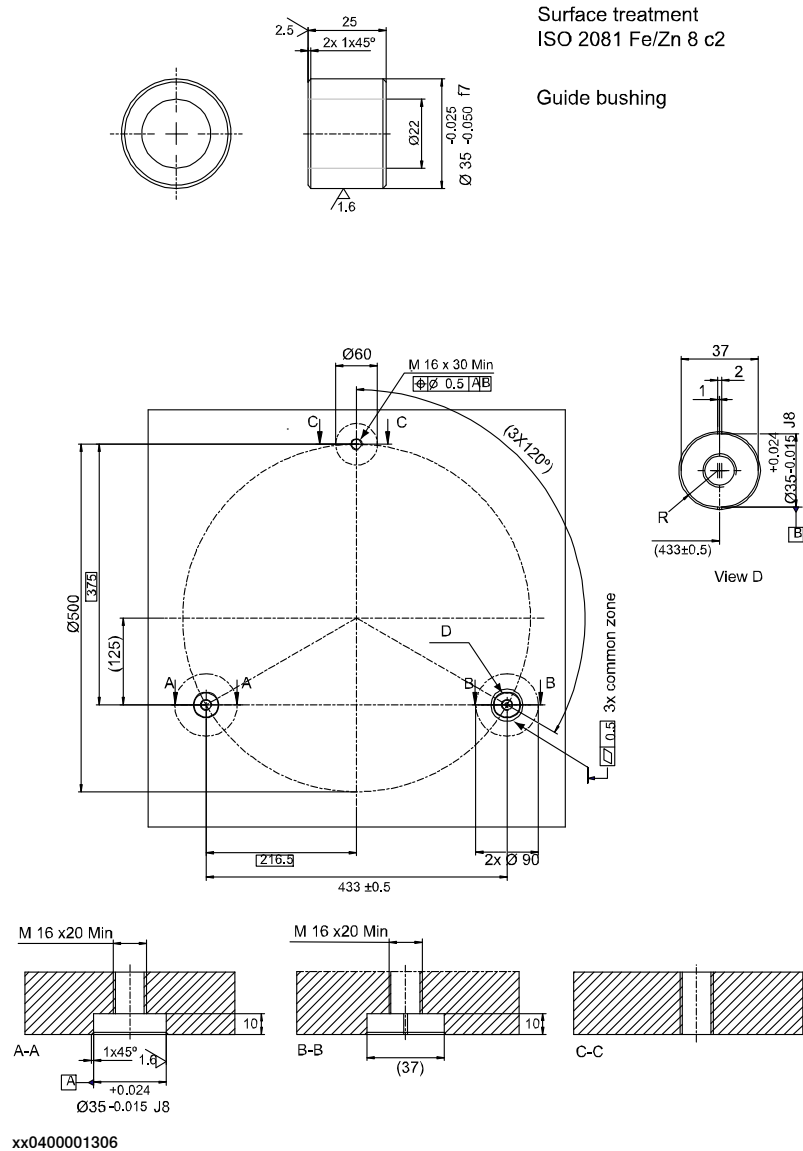

#### Attachment bolts, specification

Attachment bolts	3 pcs M16 x 60 (installation directly on foundation of steel), M16 x 70/80 (installation on foundation or base plate, using guiding sleeves)
Washers	30 x 17 x 3
Quality	8.8 (wall or angle mounted robot: Quality 12.9)
Tightening torque	200 Nm

#### Guiding sleeves

Use a pair of guiding sleeves to make the robot installation easier.

*Continues on next page*

## 2 Installation and commissioning

### 2.3.4 Orienting and securing the robot

Continued

The guiding sleeves are absolutely needed if the robot is wall or angle mounted, or if the robot is calibrated with AbsAcc.

#### Orienting and securing the robot to installation site

	Action	Note
1	Make sure the installation site for the robot conforms to the specifications in section <a href="#">Pre-installation procedure on page 50</a> .	
2	Prepare the installation site with attachment holes. If the robot is calibrated with AbsAcc, it must be installed using guiding sleeves.	Hole configuration of the base is shown in the figure <a href="#">Hole configuration, base on page 68</a> . Dimension of mounting surface and the guiding sleeves are shown in the figure <a href="#">Dimension, mounting surface and guiding sleeve on page 69</a> .
3	Lift the robot to the installation site.	Detailed in section <a href="#">Lifting robot with roundslings on page 63</a> .
4	Guide the robot gently using two of the attachment bolts while lowering it into its mounting position.	
5	Fit and tighten the <i>bolts and washers</i> in the base attachment holes.	Specified in section <a href="#">Attachment bolts, specification on page 69</a> .

#### Isolating AW manipulator



#### CAUTION

If the manipulator is used for arc welding and is mounted on a pedestal, make sure that the manipulator is isolated from the pedestal with isolators.

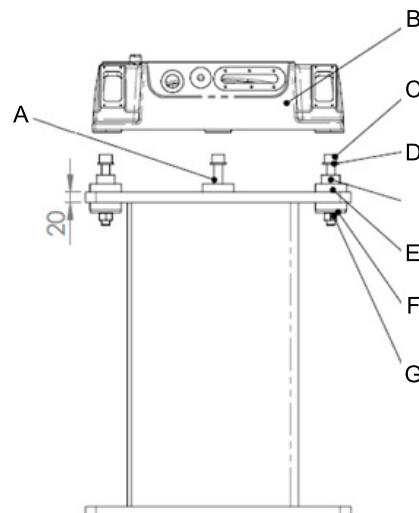

A	Attachment point, front (no guide sleeve)
B	Manipulator base
C	Screw M16x120

Continues on next page

## 2 Installation and commissioning

---

### 2.3.4 Orienting and securing the robot

*Continued*

D	Plain washer
E	Guide sleeve
F	Isolator
G	Nut M16

## 2 Installation and commissioning

### 2.3.5 Setting the system parameters for a suspended or tilted robot

### 2.3.5 Setting the system parameters for a suspended or tilted robot

#### General

The robot is configured for mounting parallel to the floor, without tilting, on delivery. The method for mounting the robot in a suspended (upside down) or tilted position is basically the same as for floor mounting, but the system parameters that describe the mounting angle (how the robot is oriented relative to the gravity) must be re-defined.



#### Note

With suspended installation, make sure that the gantry or corresponding structure is rigid enough to prevent unacceptable vibrations and deflections, so that optimum performance can be achieved.



#### Note

The allowed mounting positions are described in the product specification for the robot. The requirements on the foundation are described in [Requirements, foundation on page 52](#).

#### The x-direction in the base coordinate system

If the robot is wall mounted or mounted in a tilted position, it is important that the x-direction of the robot base coordinate system points downwards, as shown in the following figure.

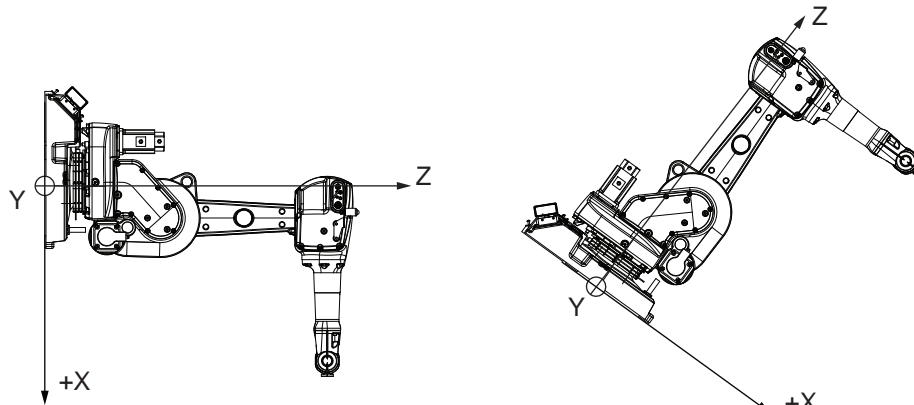

xx1200001354

*Continues on next page*

#### System parameters



#### Note

The mounting angle must be configured correctly in the system parameters so that the robot system can control the movements in the best possible way. An incorrect definition of the mounting angle will result in:

- Overloading the mechanical structure.
- Lower path performance and path accuracy.
- Some functions will not work properly, for example *Load Identification* and *Collision detection*.

#### Gravity Beta

If the robot is mounted upside down or on a wall (rotated around the y-axis), then the robot base frame and the system parameter *Gravity Beta* must be redefined. *Gravity Beta* should then be  $\pi$  (+3.141593) if the robot is mounted upside down (suspended), or  $\pm\pi/2$  ( $\pm 1.570796$ ) if mounted on a wall.

The *Gravity Beta* is a positive rotation direction around the y-axis in the base coordinate system. The value is set in radians.

#### Gravity Alpha

If the robot is mounted on a wall (rotated around the x-axis), then the robot base frame and the system parameter *Gravity Alpha* must be redefined. The value of *Gravity Alpha* should then be  $\pm\pi/2$  ( $\pm 1.570796$ ).

The *Gravity Alpha* is a positive rotation direction around the x-axis in the base coordinate system. The value is set in radians.



#### Note

The system parameter *Gravity Alpha* is not supported for all robot types. It is not supported for IRB 140, IRB 1410, IRB 1600ID, IRB 2400, IRB 4400, IRB 6400R, IRB 6400 (except for IRB 6400 200/2.5 and IRB 6400 200/2.8), IRB 6600, IRB 6650, IRB 6650S and IRB 7600 (except for IRB 7600 325/3.1).

If the robot does not support *Gravity Alpha*, then use *Gravity Beta* along with the recalibration of axis 1 to define the rotation of the robot around the x-axis.



#### Note

The parameter is supported for all robots on track when the system parameter *7 axes high performance motion* is set, see *Technical reference manual - System parameters*.

#### Gamma Rotation

*Gamma Rotation* defines the orientation of the robot foot on the travel carriage (track motion).

*Continues on next page*

## 2 Installation and commissioning

---

### 2.3.5 Setting the system parameters for a suspended or tilted robot

*Continued*

---

#### Mounting angles and values

The parameter *Gravity Beta* (or *Gravity Alpha*) specifies the mounting angle of the robot in radians. It is calculated in the following way.

$\text{Gravity Beta} = A^\circ \times 3.141593/180 = B \text{ radians}$ , where **A** is the mounting angle in degrees and **B** is the mounting angle in radians.

Example of position	Mounting angle (A °)	Gravity Beta
Floor mounted	0°	0.000000 (Default)
Tilted mounting	30°	0.523599
Wall mounting	90°	1.570796
Suspended mounting	180°	3.141593

*Continues on next page*

## 2 Installation and commissioning

### 2.3.5 Setting the system parameters for a suspended or tilted robot

*Continued*

Examples of mounting angles tilted around the Y axis (*Gravity Beta*)

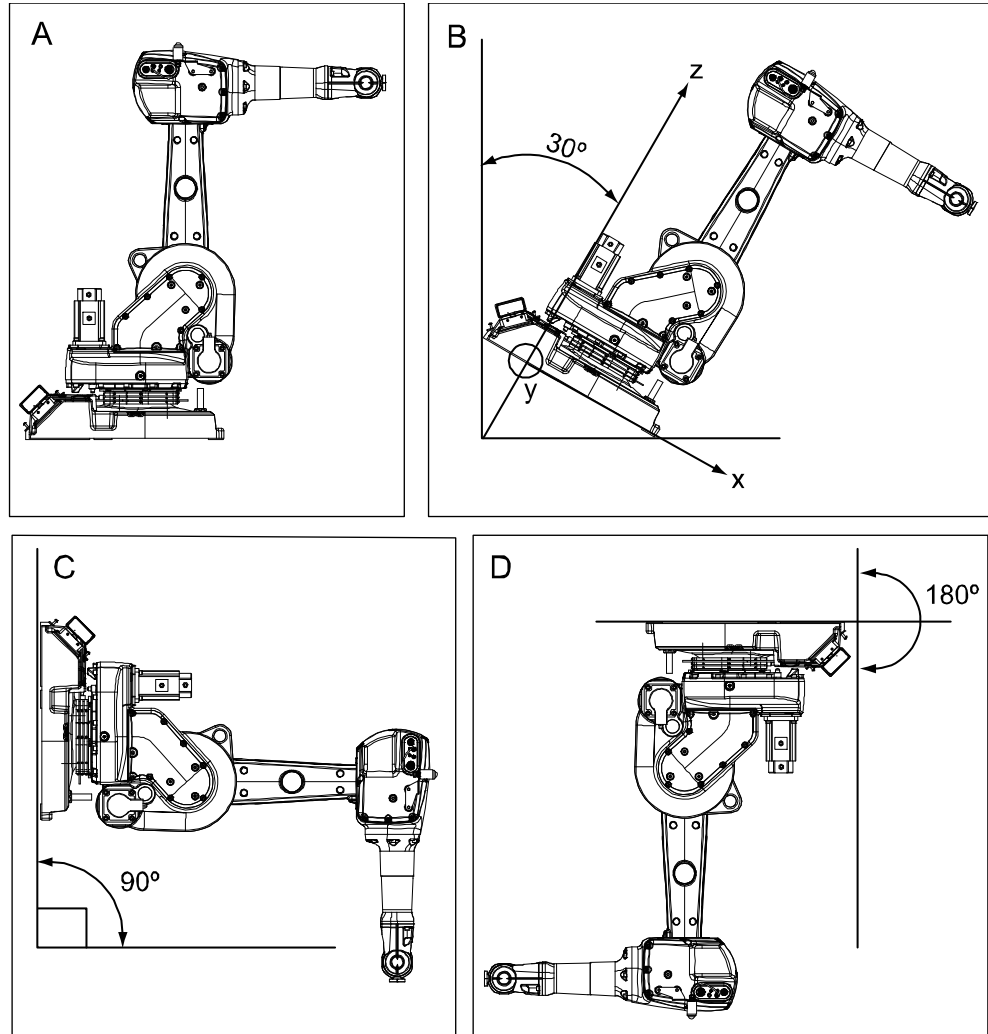

xx0600002779

A	Floor mounted
B	Tilted mounting, mounting angle 30°
C	Wall mounted, mounting angle 90°
D	Suspended mounting, mounting angle 180°

*Continues on next page*

## 2 Installation and commissioning

### 2.3.5 Setting the system parameters for a suspended or tilted robot

Continued

Examples of mounting angles tilted around the X axis (*Gravity Alpha*)

The following illustration shows the IRB 120, but the same principle applies for all robots.

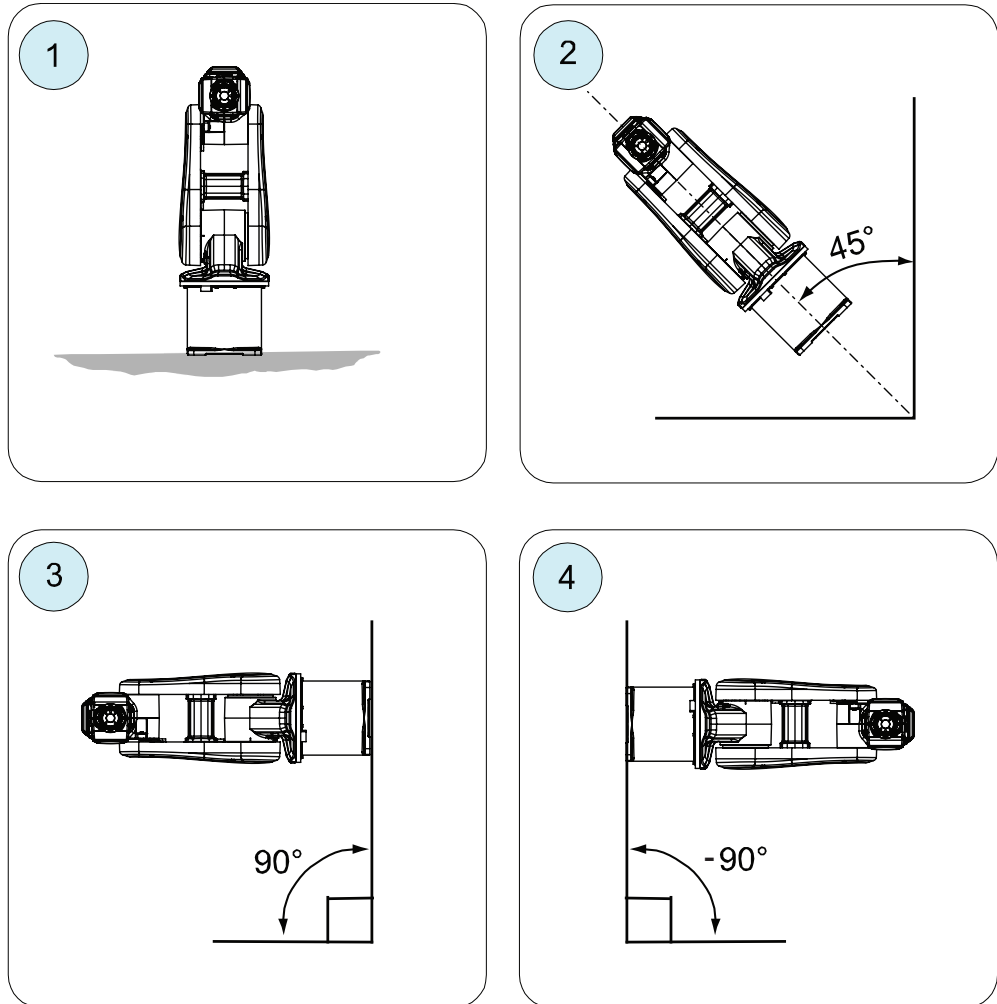

xx1500000532

Pos	Mounting angle	Gravity Alpha
1	0° (Floor mounted)	0
2	45° (Tilted)	0.785398
3	90° (Wall)	1.570796
4	-90° (Wall)	-1.570796



#### Note

For suspended robots (180°), it is recommended to use *Gravity Beta* instead of *Gravity Alpha*.

Continues on next page



---

#### Limitations in working area

If tilting a floor mounted robot or mounting the robot on a wall, the working range of axis 1 is limited. These limitations are specified in the table [Working range on page 55](#).

---

#### Defining the parameter in the IRC5 software

The value of the system parameters that define the mounting angle must be redefined when changing the mounting angle of the robot. The parameters belong to the type *Robot*, in the topic *Motion*.

How to calculate a new value is detailed in [Mounting angles and values on page 74](#).

The system parameters are described in *Technical reference manual - System parameters*.

The system parameters are redefined in the **Configuration Editor**, in RobotStudio or on the FlexPendant.

## 2 Installation and commissioning

---

### 2.3.6 Loads fitted to the robot, stopping time and braking distances

### 2.3.6 Loads fitted to the robot, stopping time and braking distances

---

#### General

Any loads mounted on the robot must be defined correctly and carefully (with regard to the position of center of gravity and mass moments of inertia) in order to avoid jolting movements and overloading motors, gears and structure.



#### CAUTION

Incorrectly defined loads may result in operational stops or major damage to the robot.

#### References

Load diagrams, permitted extra loads (equipment) and their positions are specified in the product specification. The loads must be defined in the software.

- *Operating manual - IRC5 with FlexPendant*

#### Stopping time and braking distances

The performance of the motor brake depends on if there are any loads attached to the robot. For more information, see product specification for the robot.

#### 2.3.7 Fitting equipment on the robot (robot dimensions)

##### Load areas

Extra loads can be mounted on the wrist, the upper arm housing, and on the frame. Load areas and permitted loads are shown in graphic below. The center of gravity of the extra load shall be within the marked load areas.

IRB 1600 - 5 kg and 7 kg

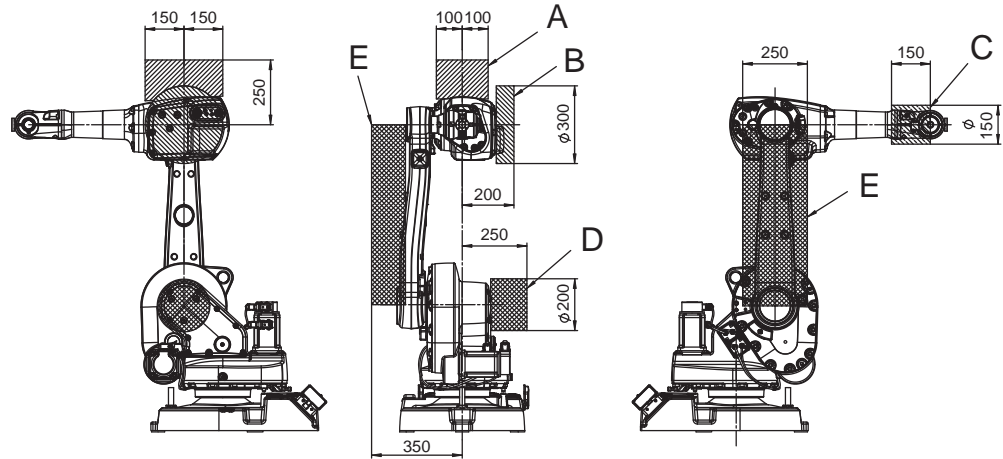

xx1000000154

Robot	Maximum load in load area					
	A	B	C	D	E	A+B+E
IRB 1600-5/X	15 kg	5 kg	0.5 kg	15 kg	15 kg	15 kg
IRB 1600-7/X	5 kg	5 kg	0.5 kg	15 kg	5 kg	5 kg

*Continues on next page*

## 2 Installation and commissioning

### 2.3.7 Fitting equipment on the robot (robot dimensions)

Continued

IRB 1600 - 6 kg, 8 kg, 10 kg, 1600ID, and 1660ID

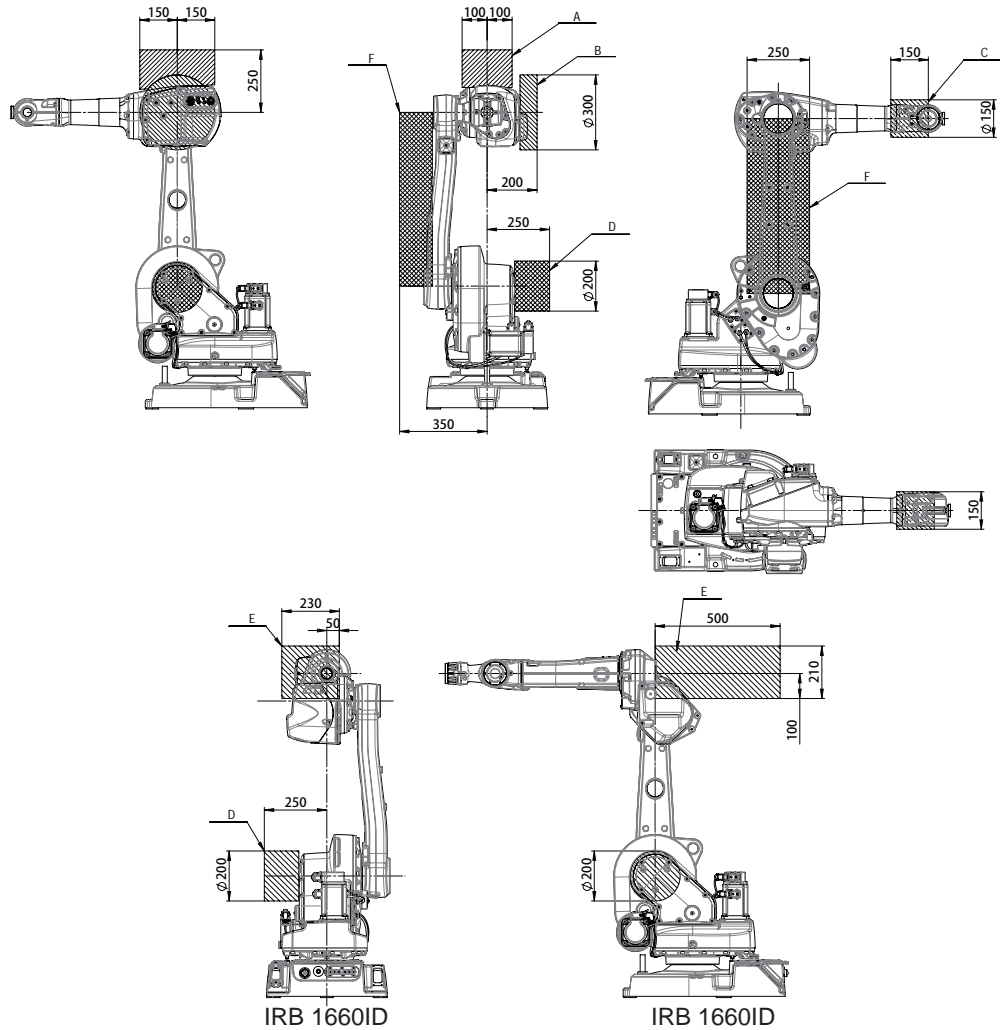

xx1500001249

Robot	Maximum load in load area							
	A	B	C	D	E	F	A+B+F	E+F
IRB 1600-6/X	15 kg	5 kg	0.5 kg	15 kg	-	15 kg	15 kg	-
IRB 1600-8/X	5 kg	5 kg	0.5 kg	15 kg	-	5 kg	5 kg	-
IRB 1600-10/X	5 kg	5 kg	0.5 kg	15 kg	-	5 kg	5 kg	-
IRB 1600ID-4/1.5	-	-	-	15 kg	15 kg	15 kg	-	15 kg
IRB 1660ID-6/1.55	-	-	-	15 kg	10 kg	15 kg	-	15 kg
IRB 1660ID-4/1.55	-	-	-	15 kg	12 kg	15 kg	-	15 kg

Continues on next page

## 2 Installation and commissioning

### 2.3.7 Fitting equipment on the robot (robot dimensions)

Continued

#### Dimensions IRB 1600-X/1.2 (1.45)

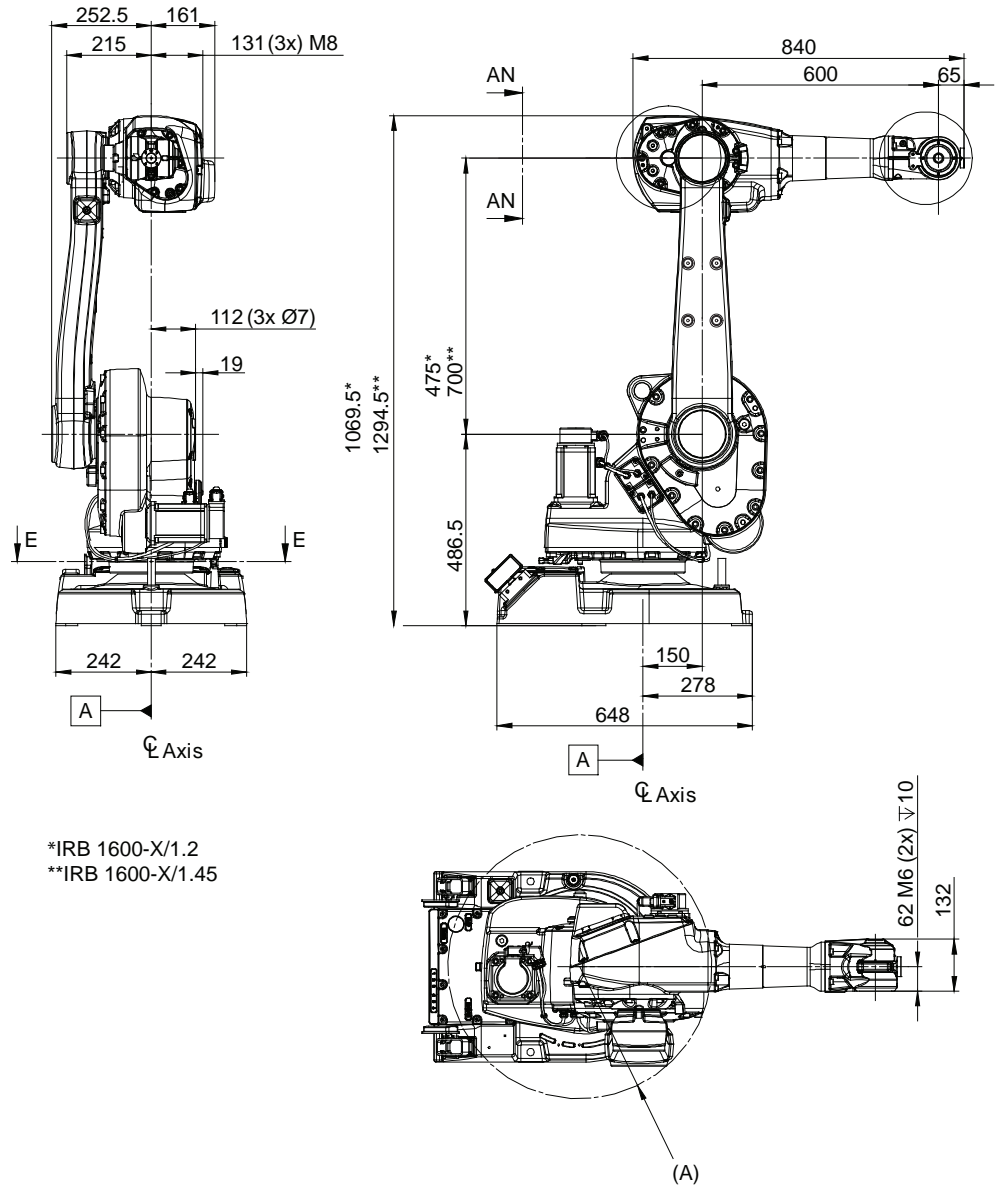

\*IRB 1600-X/1.2  
\*\*IRB 1600-X/1.45

xx1000000972

A	R335 Minimum turning radius
---	-----------------------------

Continues on next page

## 2 Installation and commissioning

### 2.3.7 Fitting equipment on the robot (robot dimensions)

Continued

#### Dimensions IRB 1600ID

##### IRB 1600ID-4/1.5

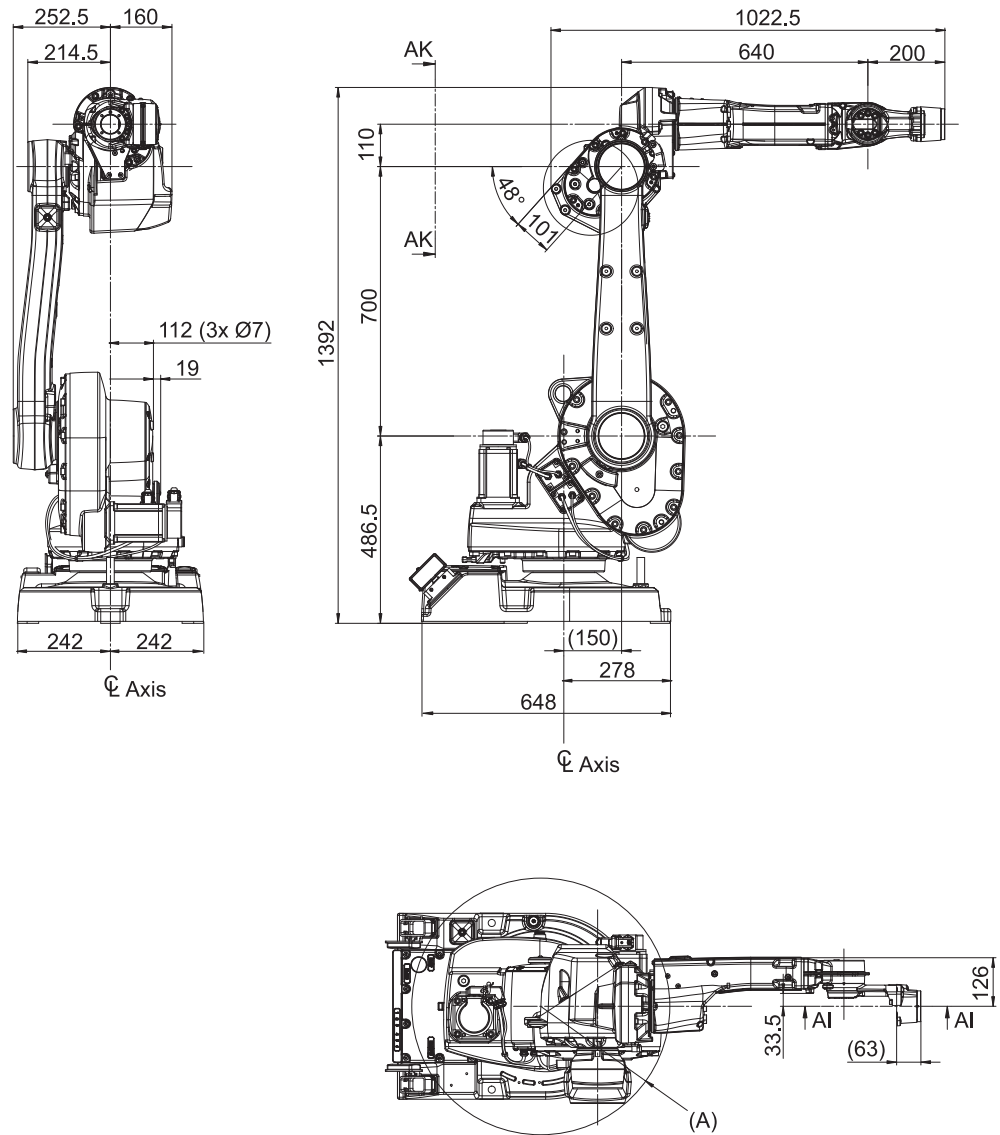

xx1000000893

A	R335 Minimum turning radius
---	-----------------------------

Continues on next page

## 2 Installation and commissioning

### 2.3.7 Fitting equipment on the robot (robot dimensions)

*Continued*

#### Dimensions IRB 1660ID

IRB 1660ID-X/1.55

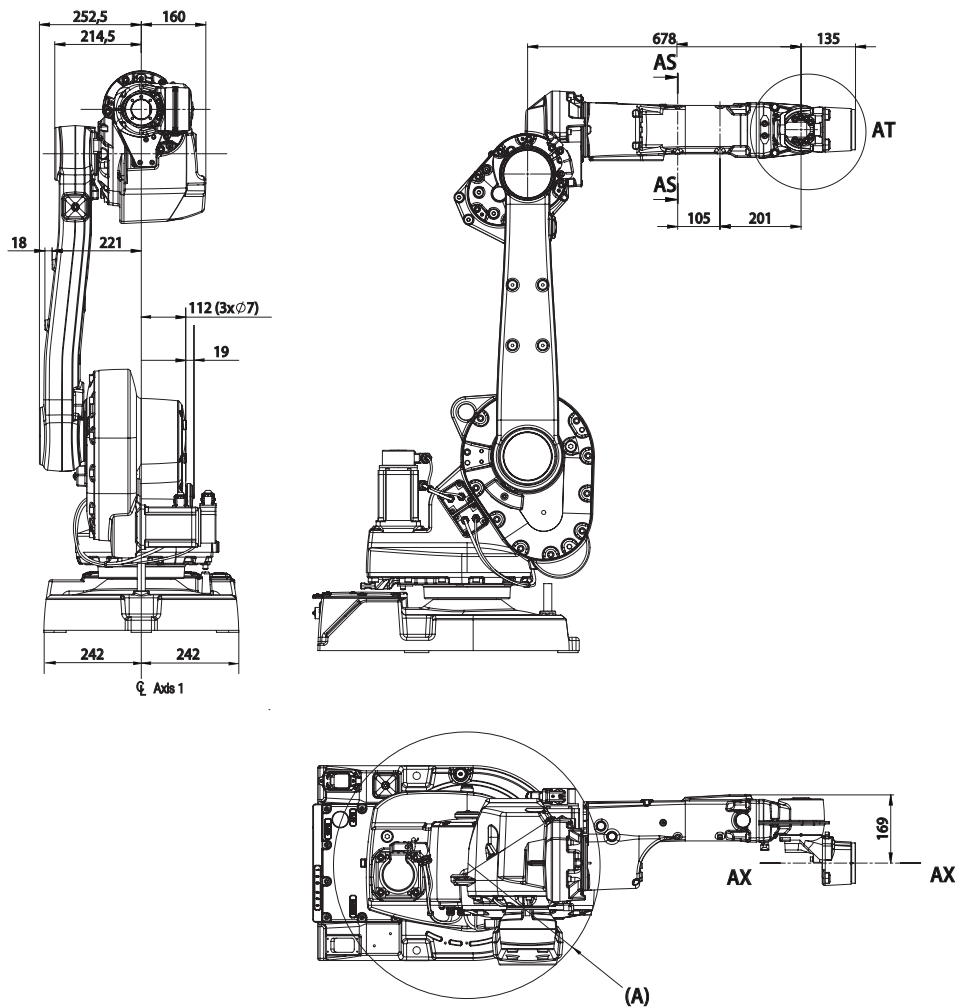

xx1500001250

A	R335 Minimum turning radius
---	-----------------------------

*Continues on next page*

## 2 Installation and commissioning

### 2.3.7 Fitting equipment on the robot (robot dimensions)

Continued

#### Holes for mounting of extra equipment for IRB 1600

The robot has holes for mounting extra equipment.

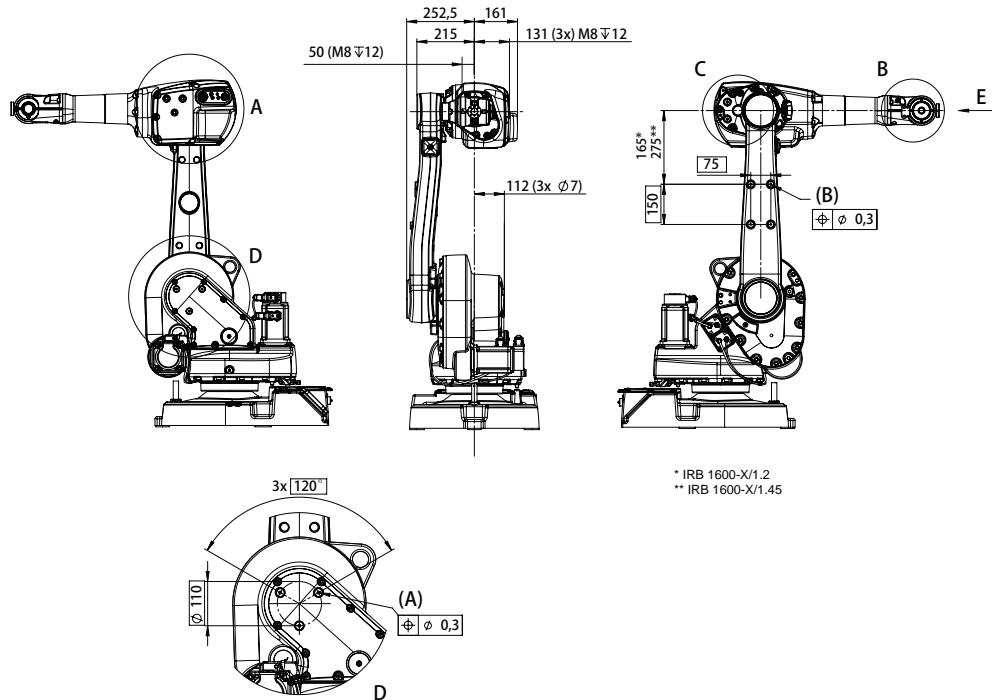

xx1500003258

A	3x∅7 maximum depth 27, mounting holes for equipment
B	4xM8 depth 12, mounting holes for equipment

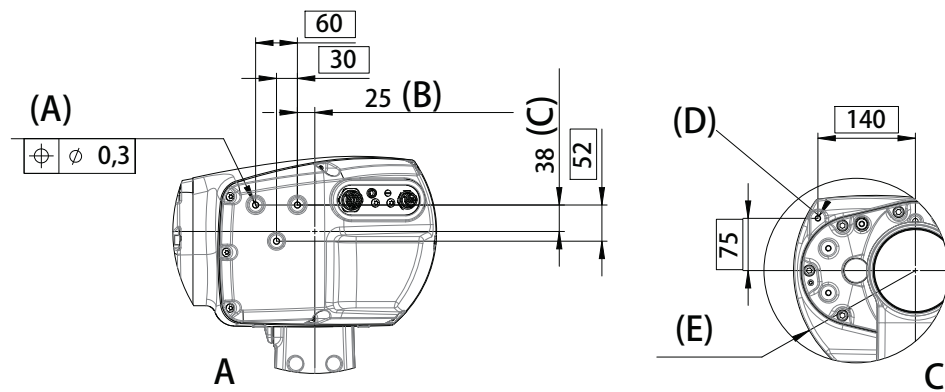

xx1500003262

A	3xM8 depth 12, mounting holes for equipment
B	From center line axis 3
C	From center line axis 4
D	3xM8 depth 16, mounting holes for equipment
E	R175, Axis 3 turning radius

Continues on next page



## 2 Installation and commissioning

### 2.3.7 Fitting equipment on the robot (robot dimensions)

*Continued*



#### Note

Note! When mounting heavier equipment, for example wire feeders in holes (A), the bracket must be supported in the opposite holes (D).

Design until June 2006

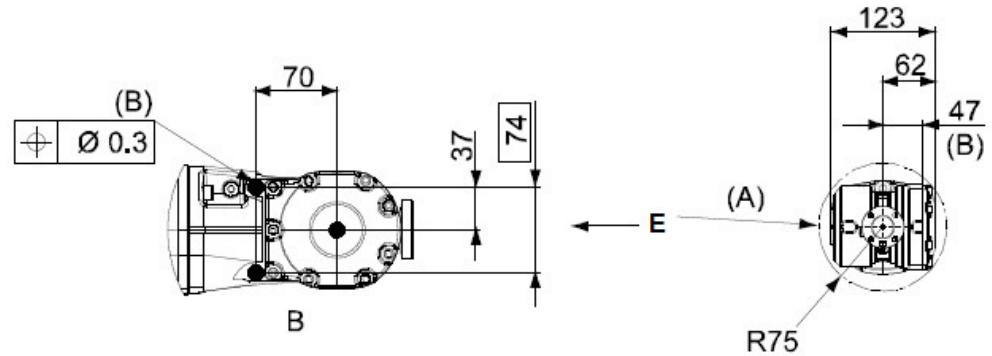

xx1500003259

A	View from E
B	2xM5 depth 7.5, mounting holes for equipment

Design after June 2006, type A

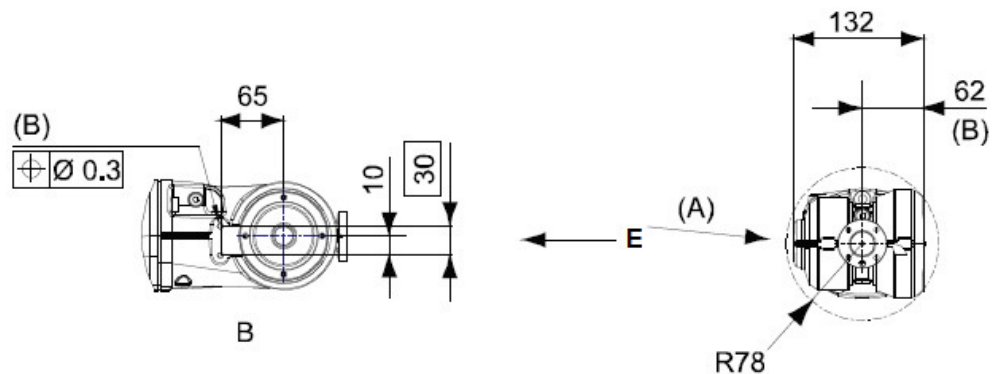

xx1500003260

A	View from E
B	2xM6 depth 10, mounting holes for equipment

*Continues on next page*

## 2 Installation and commissioning

### 2.3.7 Fitting equipment on the robot (robot dimensions)

Continued

#### Holes for mounting of extra equipment for IRB 1600ID

IRB 1600ID-4/1.5

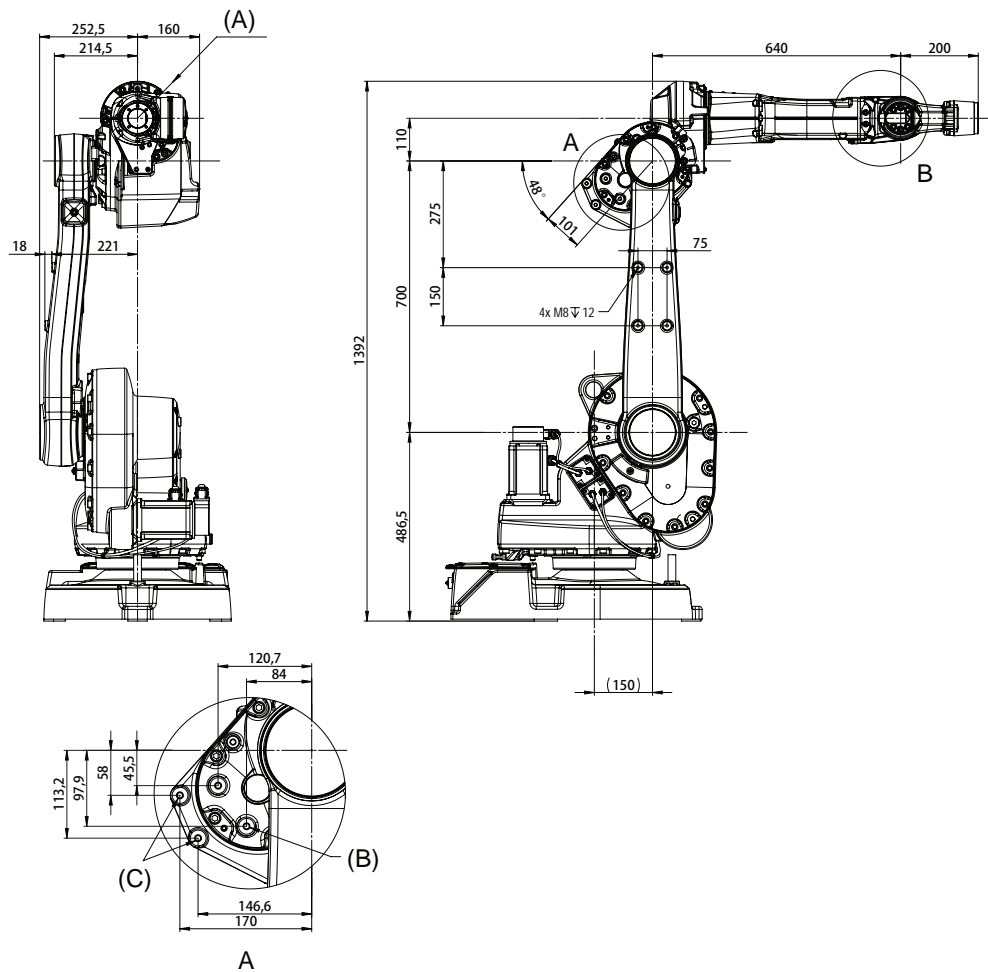

xx100000911

A	R130, smallest circumscribed radius of axis 4
B	2xM8 depth 16, mounting holes for equipment
C	2xM8, mounting holes for equipment

Continues on next page

## 2 Installation and commissioning

### 2.3.7 Fitting equipment on the robot (robot dimensions)

Continued

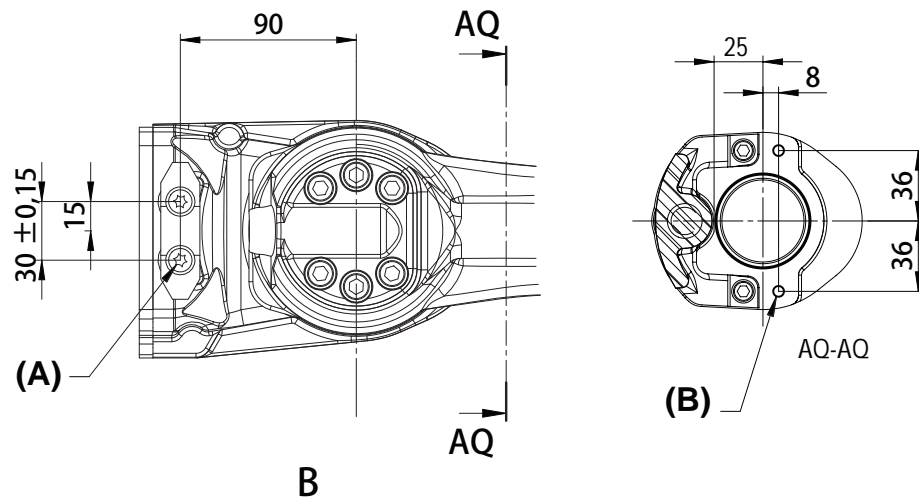

xx1500003261

A	2xM6 depth 12, mounting holes for equipment
B	2xM6 depth 12, mounting holes for equipment



#### Note

Lower arms among IRB 1600, IRB 1600ID, and IRB 1660ID are the same. For holes on the lower arm, see [Holes for mounting of extra equipment for IRB 1600 on page 84](#).

Continues on next page

## 2 Installation and commissioning

### 2.3.7 Fitting equipment on the robot (robot dimensions)

Continued

#### Holes for mounting of extra equipment for IRB 1660ID

IRB 1660ID-X/1.55

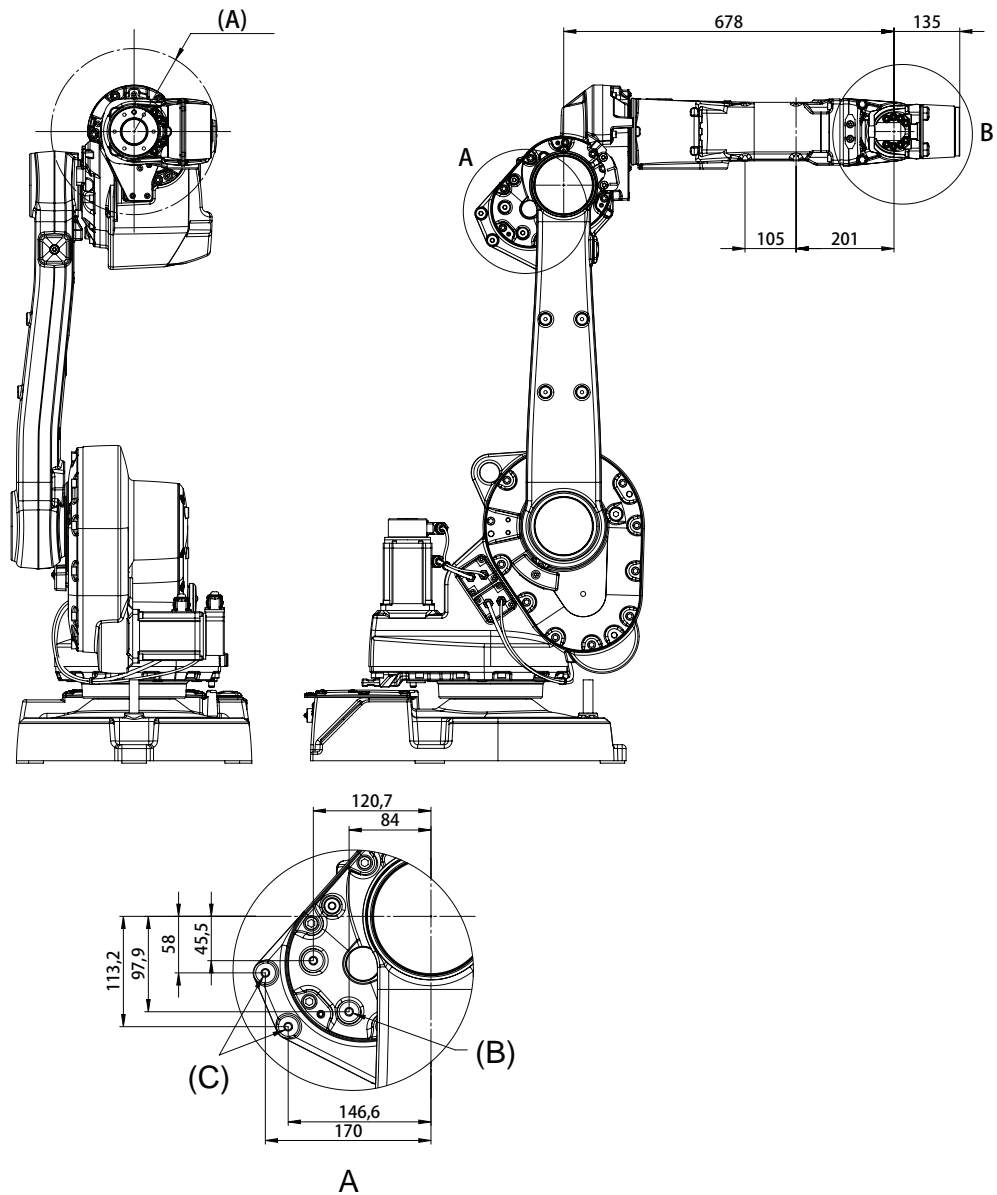

xx1500001253

A	R170.4, smallest circumscribed radius of axis 4
B	2xM8 depth 16, mounting holes for equipment
C	2xM8, mounting holes for equipment

Continues on next page

## 2 Installation and commissioning

### 2.3.7 Fitting equipment on the robot (robot dimensions)

Continued

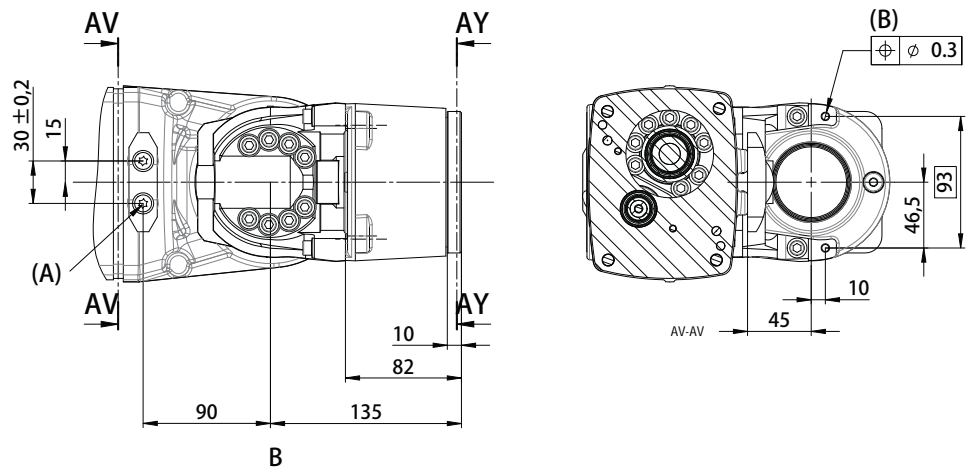

xx1500001251

A	2xM6 depth 12, mounting holes for equipment
B	2xM6 depth 18, mounting holes for equipment



#### Note

Lower arms among IRB 1600, IRB 1600ID, and IRB 1660ID are the same. For holes on the lower arm, see [Holes for mounting of extra equipment for IRB 1600 on page 84](#).

### Robot tool flange

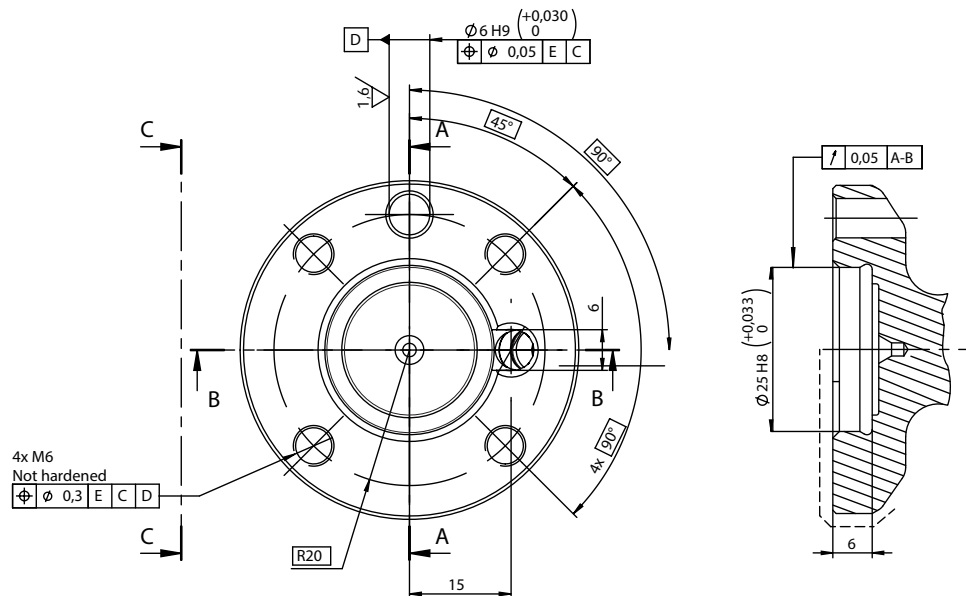

xx1000000912

Continues on next page

## 2 Installation and commissioning

### 2.3.7 Fitting equipment on the robot (robot dimensions)

Continued



#### Note

The tool flange dimensions are the same over time, but a hole for the Axis calibration method is added. This hole is not perpendicular to the surface so it is easily noticed.

### Robot tool flange for IRB 1600ID

IRB 1600ID-4/1.5

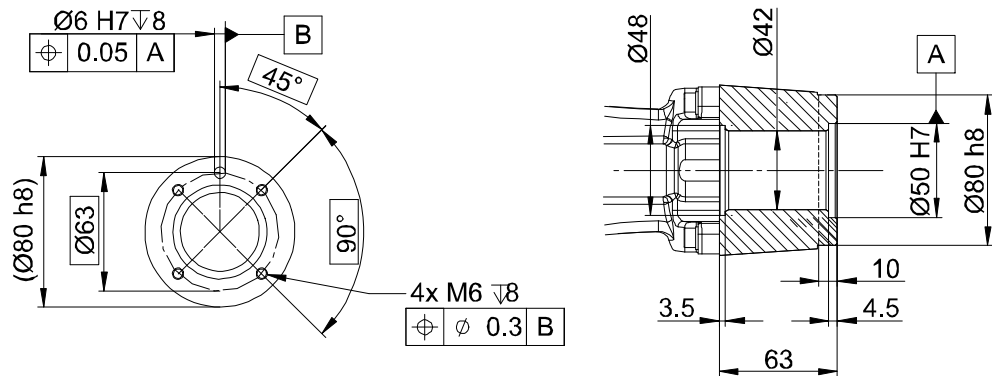

xx100000913



#### Note

Make sure that the guide pin is not inserted more than max. 9.5mm in the tool flange.

Before mounting the tool, insert the screw and measure the length of the screw sticking out, behind the tool. The length must not exceed 9.5mm. Otherwise there is a risk that the screw damages the sealing behind the tool flange.

The length, 9.5mm, refers to the total length of the screw, not just the thread length.

Continues on next page

#### Robot tool flange for IRB 1660ID

IRB 1660ID-X/1.55

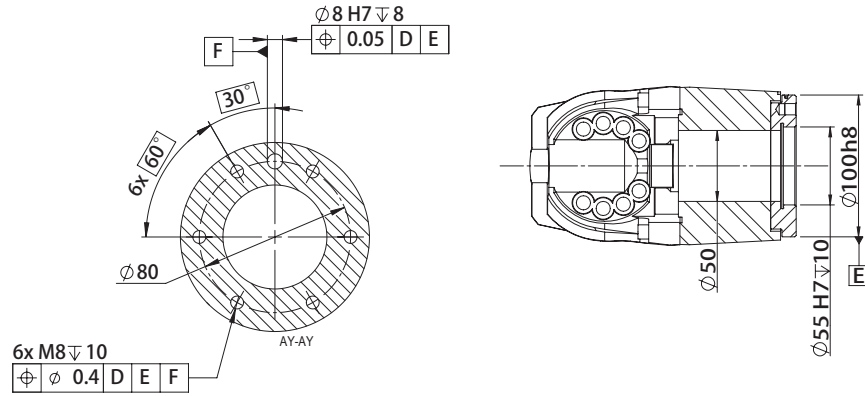

xx1500001254

#### Fastener quality

When fitting tools on the turning disk, use only screws with quality 12.9. When fitting equipment on other places, standard screws with quality 8.8 can be used.

## 2 Installation and commissioning

### 2.3.8 Installation of signal lamp for 1600 (option)

### 2.3.8 Installation of signal lamp for 1600 (option)

#### General

A signal lamp with a yellow fixed light can be mounted on the robot, as a safety device. The signal lamp is required on an UL/UR approved robot.

The lamp is active in MOTORS ON mode.



#### Note

Do not use the signal lamp option in a Clean Room environment.

#### Different signal lamps on IRB 1600 and IRB 1600ID

This instruction details how to install the signal lamp on IRB 1600. If installing the lamp on an IRB 1600ID or an IRB 1660ID robot, see [Installation of signal lamp for 1600ID/1660ID \(option\) on page 95](#).

#### Location of signal lamp

The signal lamp is fitted to the upper arm housing of the robot, as shown in the figure below.

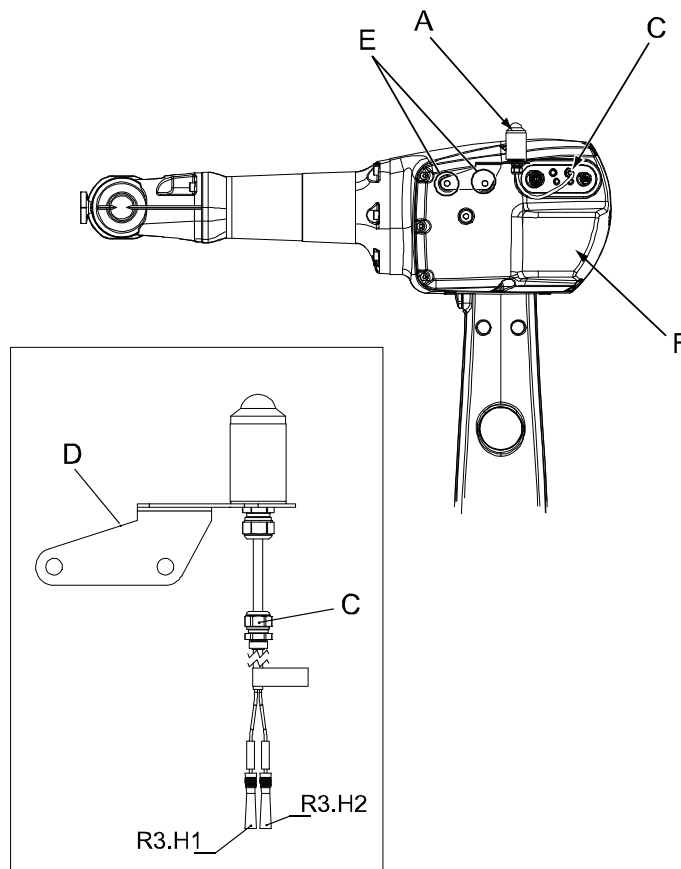

xx0400001265

A	Signal lamp
C	Cable gland

Continues on next page



## 2 Installation and commissioning

### 2.3.8 Installation of signal lamp for 1600 (option)

*Continued*

D	Cable bracket
E	Attachment holes for the signal lamp
F	Cover, upper arm housing

#### Required equipment

Equipment	Art. no.	Note
Signal lamp	3HAC050417-001	ABB Orange
	3HAC050418-001	Graphite White
Gasket, customer connections	3HAC022050-001	Replace if damaged.
Gasket, upper arm cover	3HAC022049-001	Replace if damaged.

#### Installation, signal lamp

The procedure below details how to install the signal lamp to the robot.

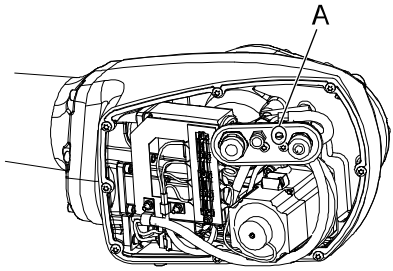
	Action	Note/Illustration
1	 <p><b>DANGER</b></p> <p>Turn off all:</p> <ul style="list-style-type: none"> <li>• electric power supply</li> <li>• hydraulic pressure supply</li> <li>• air pressure supply</li> </ul> <p>to the robot, before entering the robot working area.</p>	
2	Remove the <i>cover from the upper arm housing</i> to get access to the connectors inside the housing.	Shown in the figure <a href="#">Location of signal lamp on page 92</a> .
3	Remove the protection plug (A) from the insertion hole in the contact panel. Run the cables of the lamp through the hole in the contact panel. Secure the cable gland in the hole.	 <p>xx0400001264</p> <ul style="list-style-type: none"> <li>• A: Plug with o-ring, M10</li> </ul>
4	Connect the lamp connectors, R3.H1 and R3.H2 and place the cables safely inside the housing.	
5	Take out the lamp unit through the hole in the <i>upper arm housing cover</i> and refit the cover. Make sure the gaskets are not damaged.	Shown in the figure <a href="#">Location of signal lamp on page 92</a> .

*Continues on next page*

## 2 Installation and commissioning

### 2.3.8 Installation of signal lamp for 1600 (option)

Continued

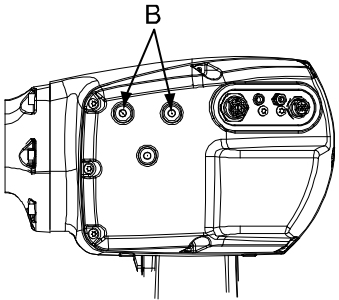
	Action	Note/Illustration
6	Fit the <i>cable bracket</i> of the signal lamp to the two mounting holes in the upper arm housing (B).	Shown in the figure <a href="#">Location of signal lamp on page 92</a> .  xx0400001263 <ul style="list-style-type: none"><li>• B: Mounting holes, M8 x 12</li></ul>
7	The signal lamp is now ready for use and is lit in MOTORS ON mode.	

### 2.3.9 Installation of signal lamp for 1600ID/1660ID (option)

#### General

A signal lamp with a yellow fixed light can be mounted on the robot, as a safety device. The signal lamp is required on an UL/UR approved robot.

The lamp is active in MOTORS ON mode.



#### Note

Do not use the signal lamp option in a Clean Room environment.

#### Location of signal lamp

The signal lamp is fitted to the upper arm housing of the robot, as shown in the figure below

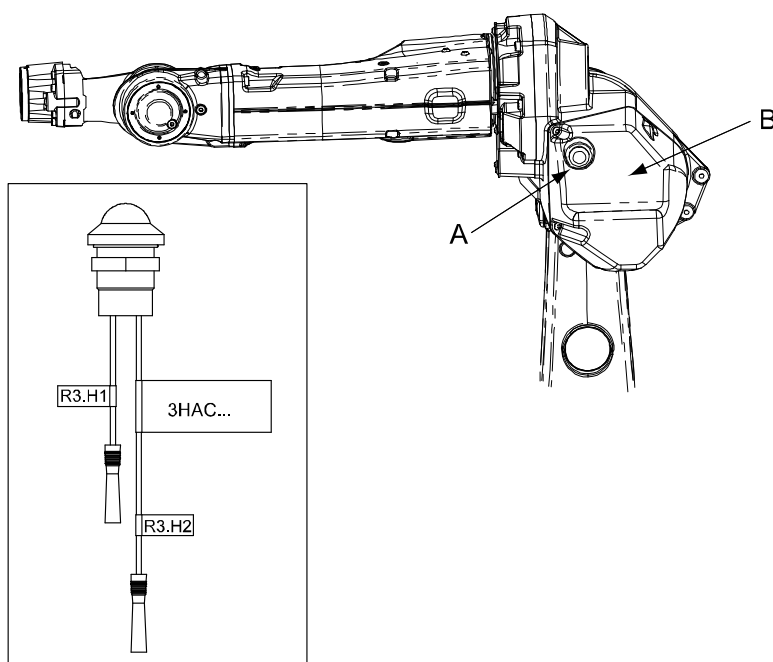

xx0700000100

A	Signal lamp
B	Cover, upper arm housing

#### Required equipment

Equipment	Art. no.	Note
Signal lamp	3HAC9258-1	
Drill	-	Diameter 22.5 mm

*Continues on next page*

## 2 Installation and commissioning

### 2.3.9 Installation of signal lamp for 1600ID/1660ID (option)

Continued

Equipment	Art. no.	Note
Standard toolkit	-	The contents of the toolkit is defined in section, <a href="#">Standard tools on page 383</a>

#### Installation, signal lamp

	Action	Note
1	 <b>DANGER</b> Turn off all: <ul style="list-style-type: none"><li>• electric power supply</li><li>• hydraulic pressure supply</li><li>• air pressure supply</li></ul> to the robot, before entering the robot working area.	
2	Remove the <i>cover from the upper arm housing</i> .	Shown in the figure <a href="#">Location of signal lamp on page 95</a> .
3	On the cover there is a mark where the lamp is to be installed. Find the mark and drill a hole with a diameter of 22.5mm.	
4	Fit the lamp and tighten the nut.	
5	In the upper arm housing find the two cables marked R3.H1 and R3.H2 and connect them with the lamp	
6	Refit the cover on the upper arm housing.	
7	The signal lamp is now ready for use and is lit in MOTORS ON mode.	

#### 2.3.10 Installation of the wire feeder shelf for 1600ID/1660ID

##### Location of shelf, wire feeder

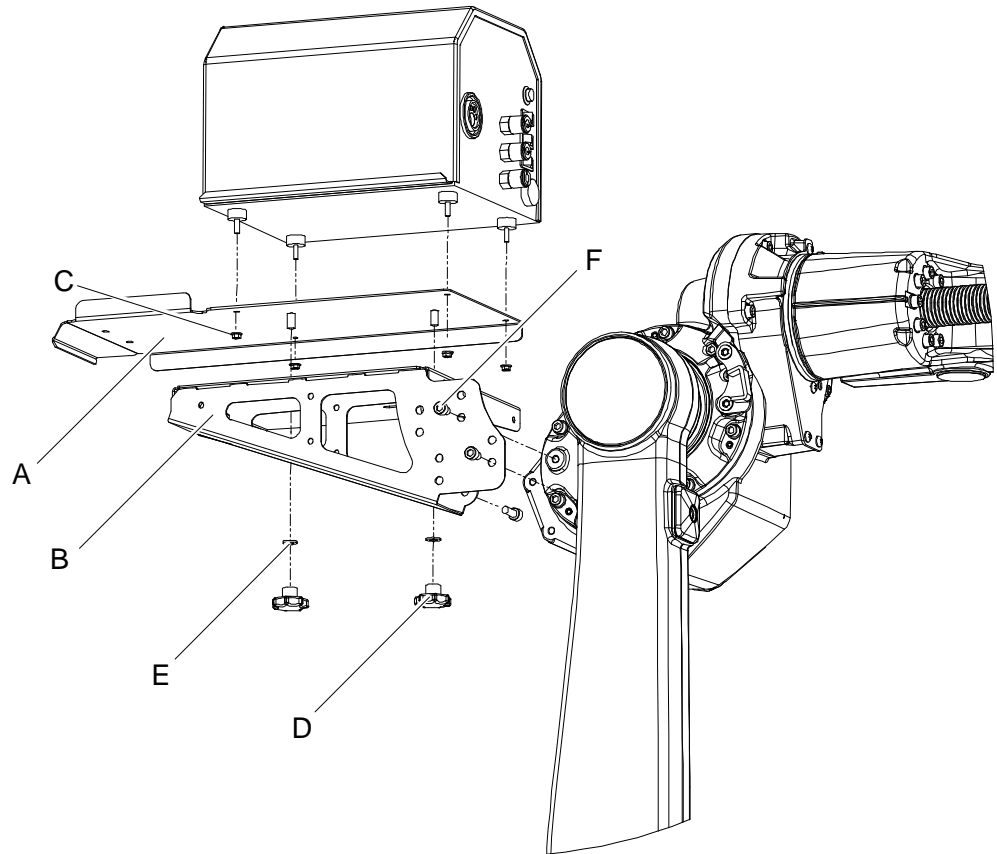

xx0700000311

A	Bracket ESAB wire feeder
B	Shelf, wire feeder
C	Hexagon nut with flange M5
D	Knob
E	Plain washer (8.4x16x1.6)
F	Hex socket head cap screw (M8x12)

##### Fitting the wire feeder shelf

	Action	Note
1	Fit the Shelf, wire feeder (B) using the four (4) Hex socket head cap screw (F).	Shown in figure <a href="#">Location of shelf, wire feeder on page 97</a>

*Continues on next page*

## 2 Installation and commissioning

### 2.3.10 Installation of the wire feeder shelf for 1600ID/1660ID

Continued

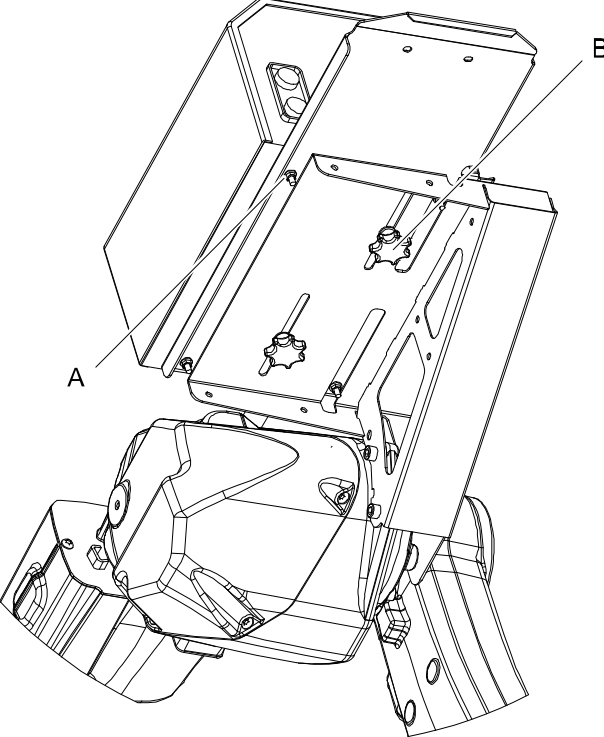
	Action	Note
2	Fit the bracket on the wire feeder using the four (4) Hexagon nut with flange (A).	 <p data-bbox="794 1061 898 1077">xx0700000312</p> <p data-bbox="826 1099 1171 1160">A Hexagon nut with flange M5 B Knob</p>
3	Fit the wire feeder with the mounted bracket on the Shelf, wire feeder and mount the two knobs.	

## 2.4 Restricting the working range

### 2.4.1 Axes with restricted working range

#### General

When installing the robot, make sure that it can move freely within its entire working space. If there is a risk that it may collide with other objects, its working space should be limited.

The working range of the following axes may be restricted:

- Axis 1, hardware (mechanical stop and position switch) and software
- Axis 2, hardware (mechanical stop) and software
- Axis 3, hardware (mechanical stop) and software.

This section describes how to install hardware that restricts the working range.



#### Note

Adjustments must also be made in the robot configuration software (system parameters). References to relevant manuals are included in the installation procedures.

## 2 Installation and commissioning

### 2.4.2 Installation of additional mechanical stops on axis 1

#### 2.4.2 Installation of additional mechanical stops on axis 1

##### General

This section details how to install additional mechanical stops on axis 1 in order to restrict the working range of the axis.

##### Restrictions in working range

The working range of axis 1 can be restricted by fitting one or two additional mechanical stops on the casted groove at the base.

The figure below shows both the minimum and maximum working range of the robot, when restricted by the additional mechanical stops. The working range can be restricted freely within the shown scope, depending on where the mechanical stop is installed along the casted groove.

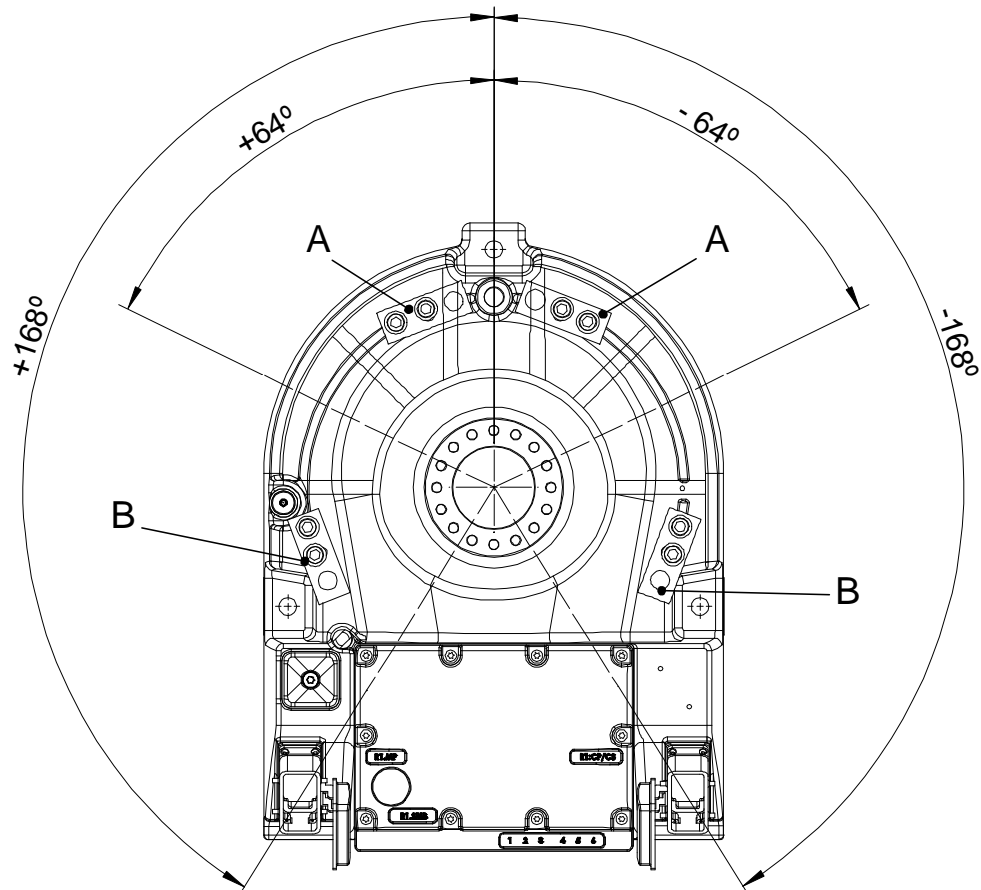

xx0400001286

A	Mounting position of two additional stops for maximum working area ( $\pm 168^\circ$ )
B	Mounting position of two additional stops for minimum working area ( $\pm 64^\circ$ )

*Continues on next page*



Keep X direction downwards (tilted or wall mounted robot)

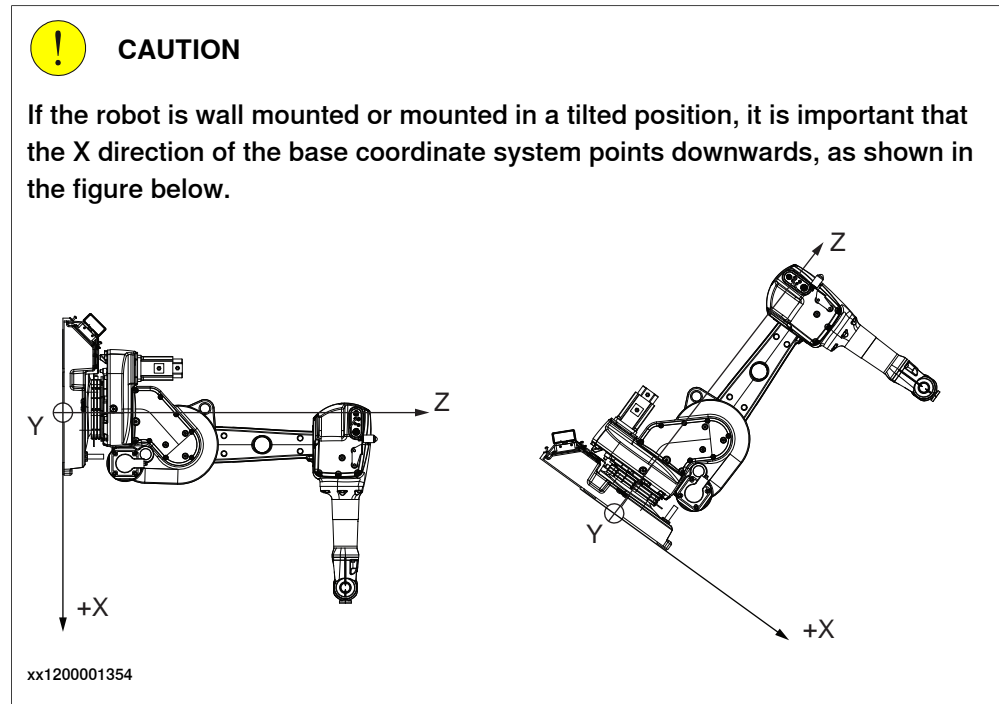

Negative directions in axis 1 have extra gravity force (tilted or wall mounted robots)

If the robot is wall mounted or mounted in a tilted position, the additional mechanical stop pin restricts the robot when the axis 1 moves in a positive direction, for example from 0° and upwards to 90° (b).

The stop pin does not manage the extra gravity force that comes from when axis 1 moves in a negative direction, for example from 180° downwards to 90° (a).

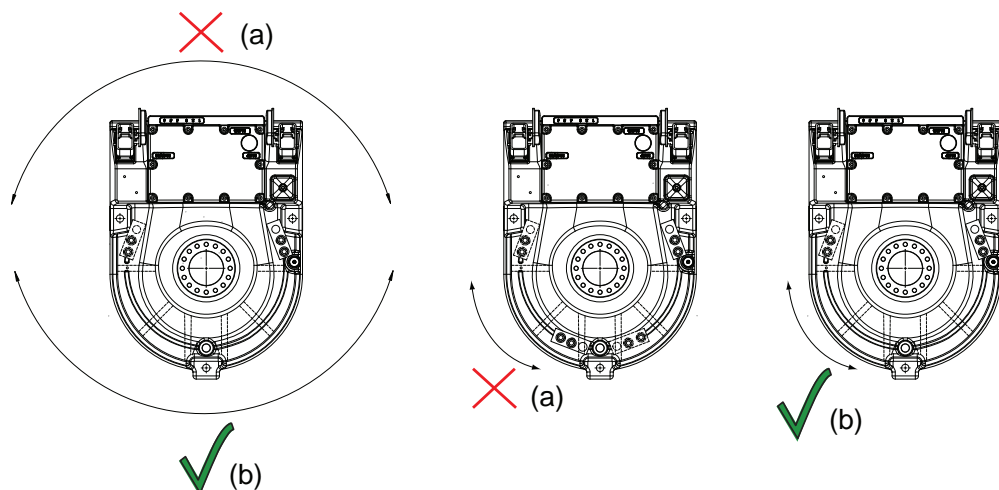

(a)	The additional stop pin does not manage the extra gravity force in this restricted working area (for tilted or wall mounted robots).
(b)	The additional stop pin manages to restrict this working area (for tilted or wall mounted robots).

*Continues on next page*

## 2 Installation and commissioning

### 2.4.2 Installation of additional mechanical stops on axis 1

Continued

#### Required equipment

Equipment	Art. no.	Note
Working range limit axis 1	3HAC026119-001	Includes mechanical stops (2 pcs), attachment bolts and washers.
<i>Technical reference manual - System parameters</i>	-	Art. no. is specified in section <a href="#">References on page 10</a> .

#### Illustration, mechanical stop, axis 1

The additional mechanical stop of axis 1 is fitted to the base of the robot, as shown in the figure below.

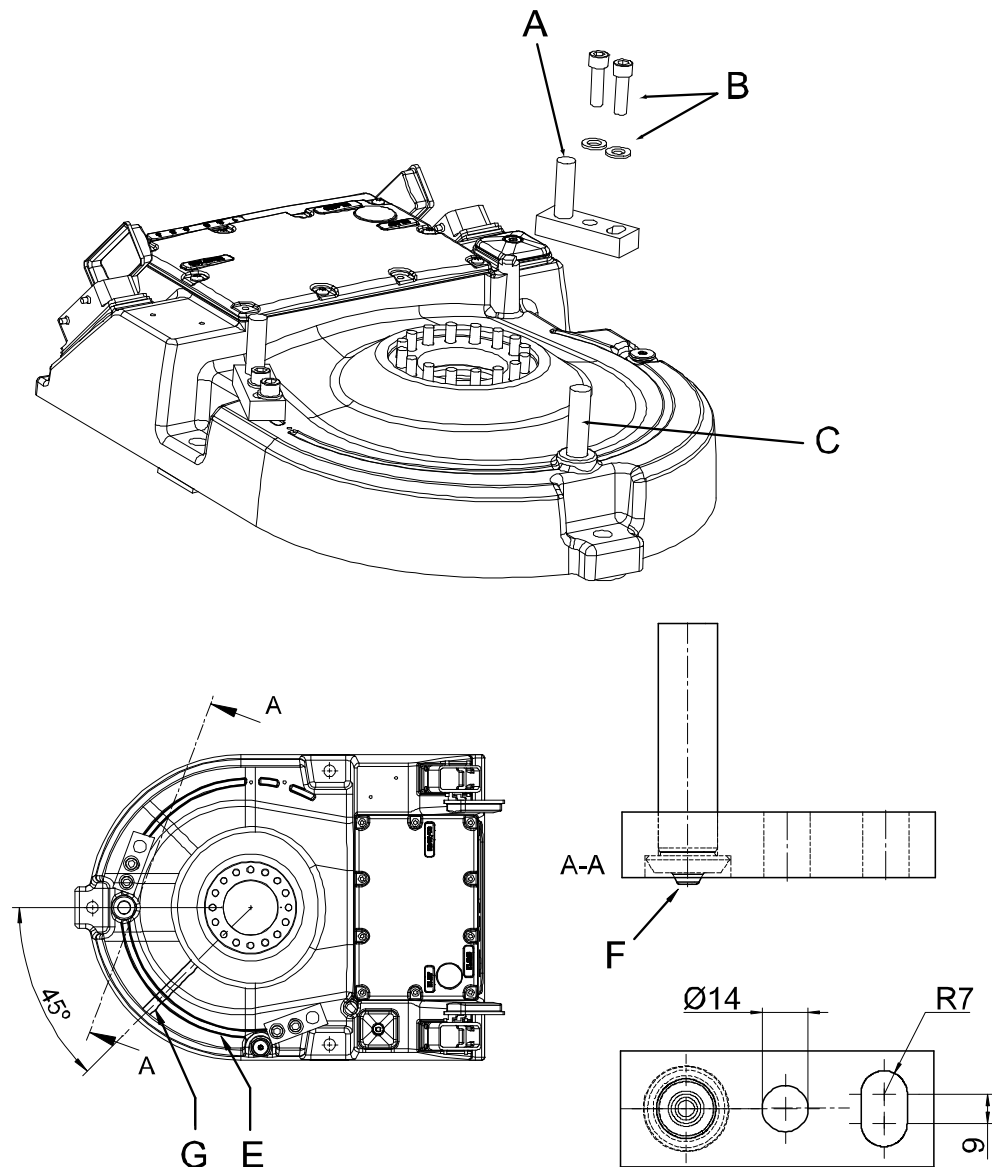

xx0400001287

A	Mechanical stop, axis 1 (additional)
B	Attachment bolts and washers, mechanical stop

Continues on next page

## 2 Installation and commissioning

### 2.4.2 Installation of additional mechanical stops on axis 1

*Continued*

C	Stop pin (standard)
E	Casted groove
F	Guiding pin
G	Hidden stiffening ribs

#### Installation of mechanical stop, axis 1

The procedure below details how to install the mechanical stop to axis 1.

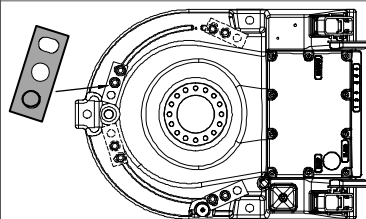
	Action	Note/Illustration
1	 <p><b>DANGER</b></p> <p>Turn off all:</p> <ul style="list-style-type: none"> <li>• electric power supply</li> <li>• hydraulic pressure supply</li> <li>• air pressure supply</li> </ul> <p>to the robot, before entering the robot working area.</p>	
2	<p>Place the stop at the base, with the <i>guiding pin</i> in the casted groove. Turn the stop until the holes align with the groove.</p> <p>The stop can be mounted in either direction, resulting in differences in the working range.</p>	 <p>xx0400001288</p> <p>Also see the figure <i>Illustration, mechanical stop, axis 1</i> on page 102.</p>
3	<p>Drill two holes in the casted groove, with guidance from the circular and the elliptical hole.</p> <p>Drill the holes through 10.2 mm.</p> <p>If drilling in a stiffening rib, drill depth must be min. 30 mm.</p>	
4	<p>Cut the threads M12.</p> <p>If cutting in a stiffening rib, thread depth must be min. 23 mm.</p>	
5	Fit the stop to the base without tightening the bolts.	
6	Turn axis 1 manually and check the working area between the stops.	How to release the holding brake of the axis motor is detailed in section <i>Manually releasing the brakes</i> on page 66.
7	Tighten the bolts.	2 pcs/stop: M12 x 40, tightening torque: 85 Nm.
8	Adjust the software working range limitations (system parameter configuration) to correspond to the mechanical limitations.	The system parameters that must be changed ( <i>Upper joint bound</i> and <i>Lower joint bound</i> ) are described in <i>Technical reference manual - System parameters</i> .

*Continues on next page*

## 2 Installation and commissioning

---

### 2.4.2 Installation of additional mechanical stops on axis 1

*Continued*

	Action	Note/Illustration
9	 <b>WARNING</b> If the <i>mechanical stop pin</i> is deformed after a hard collision, it must be replaced! Deformed <i>movable stops</i> and/or <i>additional stops</i> as well as deformed <i>attachment screws</i> must also be replaced after a hard collision.	

#### 2.4.3 Installation of additional mechanical stop on axis 2

##### General

This section details how to install an additional mechanical stop on axis 2 in order to restrict the working range of the axis.

##### Restrictions in working range

The working range of axis 2 can be restricted by fitting an additional mechanical stop at the frame. The working range can only be restricted backwards, as shown in the figures below. Notice the different working ranges for the different models!

IRB 1600 - x/1.2

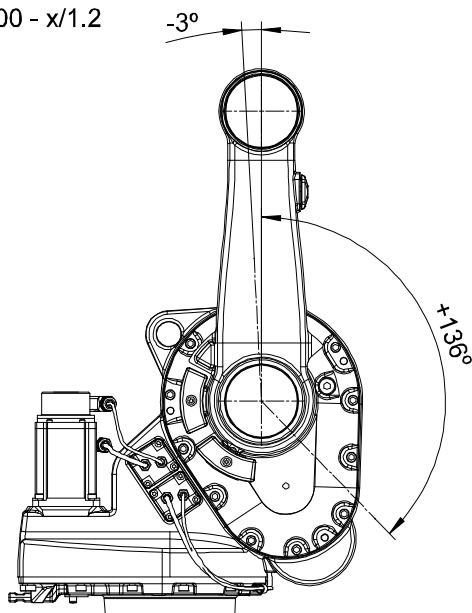

xx0400001289

*Continues on next page*

## 2 Installation and commissioning

### 2.4.3 Installation of additional mechanical stop on axis 2

Continued

IRB 1600 - x/1.45

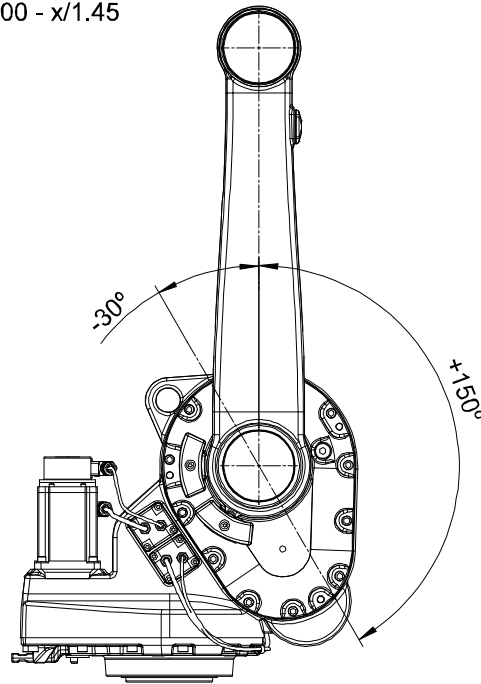

xx0400001290

#### Illustration, mechanical stop, axis 2

The additional mechanical stop for axis 2 is fitted together with a damper to the frame, as shown in the figure below.

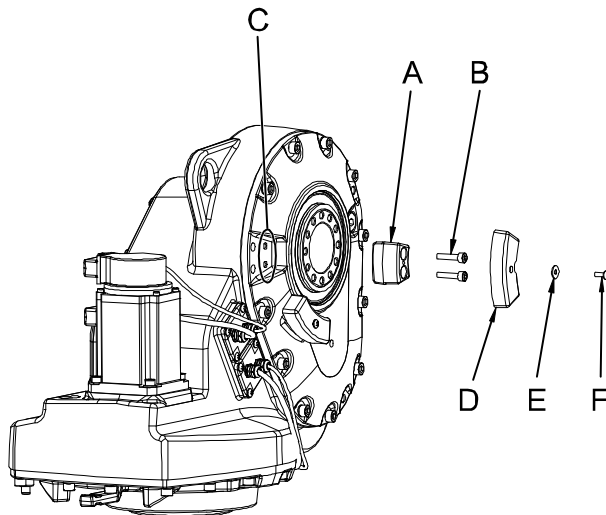

xx0400001291

A	Mechanical stop, axis 2
B	Attachment bolts, mechanical stop (2 pcs)
C	Attachment holes, mechanical stop
D	Damper, axis 2
E	Washer
F	Attachment screw, damper

Continues on next page

## 2 Installation and commissioning

### 2.4.3 Installation of additional mechanical stop on axis 2

*Continued*

#### Required equipment

Equipment	Art. no.	Note
Working range limit axis 2	3HAC026120-001	Includes mechanical stop, damper and attachment bolts.
<i>Technical reference manual - System parameters</i>	-	Art. no. is specified in section <a href="#">References on page 10</a> .

#### Installation of mechanical stop, axis 2

The procedure below details how to install the mechanical stop to axis 2.

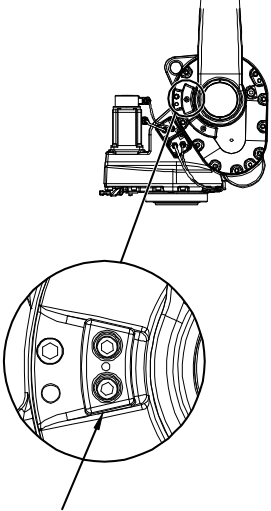
	Action	Note/Illustration
1	 <p><b>DANGER</b></p> <p>Turn off all:</p> <ul style="list-style-type: none"> <li>• electric power supply</li> <li>• hydraulic pressure supply</li> <li>• air pressure supply</li> </ul> <p>to the robot, before entering the robot working area.</p>	
2	Fit the mechanical stop to the frame, without tightening the bolts.	Attachment holes are shown in the figure <a href="#">Illustration, mechanical stop, axis 2 on page 106</a> .
3	Make sure that the stop is in contact with the lower boss on the gearbox, as the arrow shows in the figure to the right.	 <p>xx0400001292</p> <p><b>Note!</b> It is important that the mechanical stop is fitted in contact with the lower boss on the gearbox!</p>
4	Tighten the attachment bolts.	2 pcs; M8 x 35, tightening torque: 25 Nm.
5	Fit the <i>damper</i> to the mechanical stop, with its attachment screw and washer. Tighten the screw.	Shown in the figure <a href="#">Illustration, mechanical stop, axis 2 on page 106</a> .

*Continues on next page*

## 2 Installation and commissioning

### 2.4.3 Installation of additional mechanical stop on axis 2

Continued

	Action	Note/Illustration
6	Adjust the software working range limitations (system parameter configuration) to correspond to the mechanical limitations.	The system parameters that must be changed ( <i>Upper joint bound</i> and <i>Lower joint bound</i> ) are described in <i>Technical reference manual - System parameters</i> .
7	 <b>WARNING</b>  If the <i>mechanical stop pin</i> is deformed after a hard collision, it must be replaced!  Deformed <i>movable stops</i> and/or <i>additional stops</i> as well as deformed <i>attachment screws</i> must also be replaced after a hard collision.	



#### 2.4.4 Installation of additional mechanical stops on axis 3

##### General

This section details how to install an additional mechanical stop on axis 3 in order to restrict the working range of the axis.

##### Restrictions in working range

The working range of axis 3 can be restricted into two different working areas, as shown in the two figures below. Notice the differences between the different models.

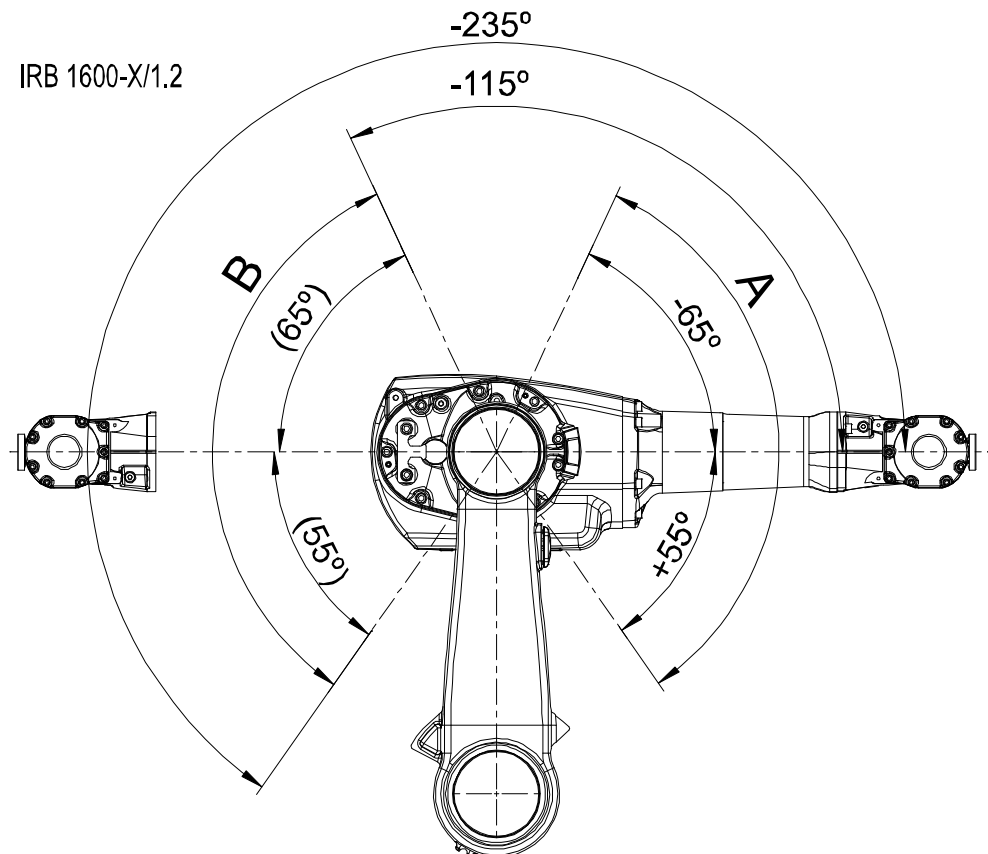

xx0400001283

-	Robot models IRB 1600 - x/1.2
A	Working range A
B	Working range B

*Continues on next page*

## 2 Installation and commissioning

### 2.4.4 Installation of additional mechanical stops on axis 3

Continued

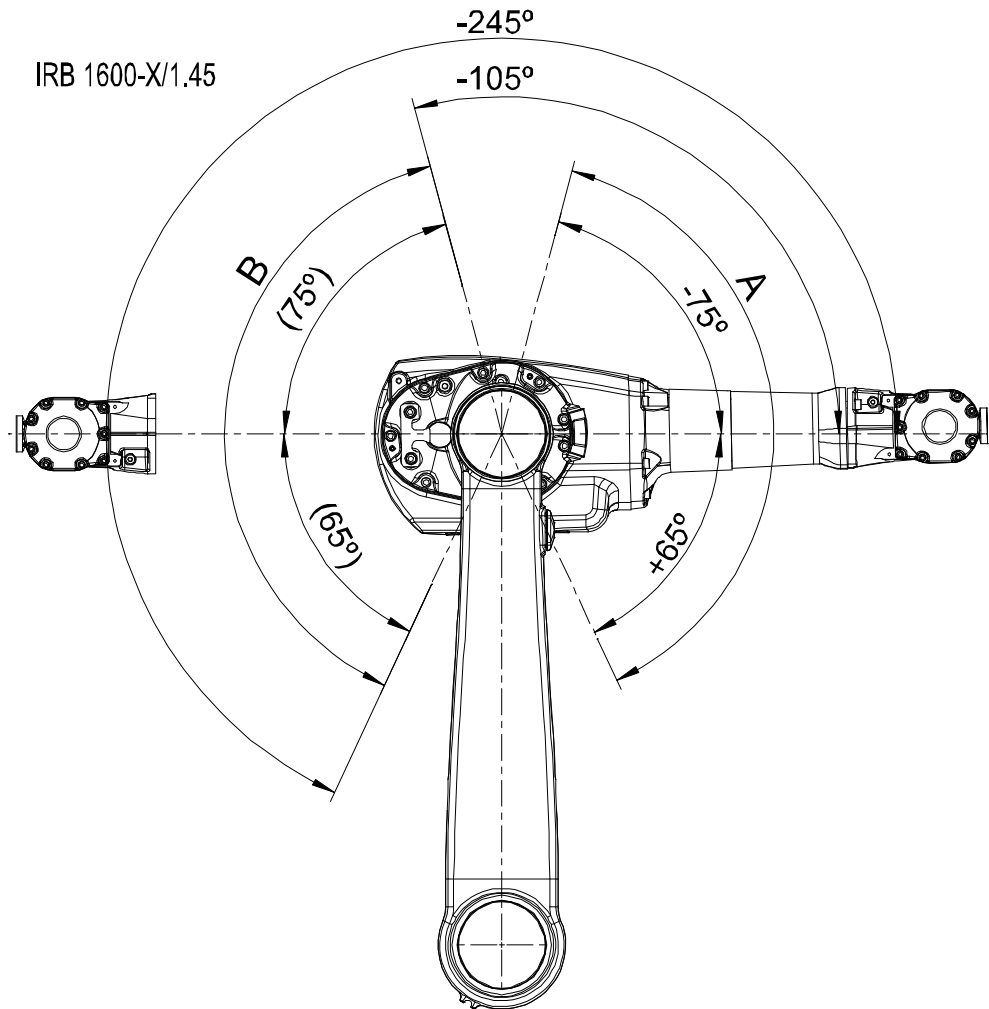

xx0400001284

-	Robot models IRB 1600 - x/1.45
A	Working range A
B	Working range B

Continues on next page

#### Illustration, mechanical stop, axis 3

The mechanical stop is installed at the upper arm housing, as shown in the figure below.

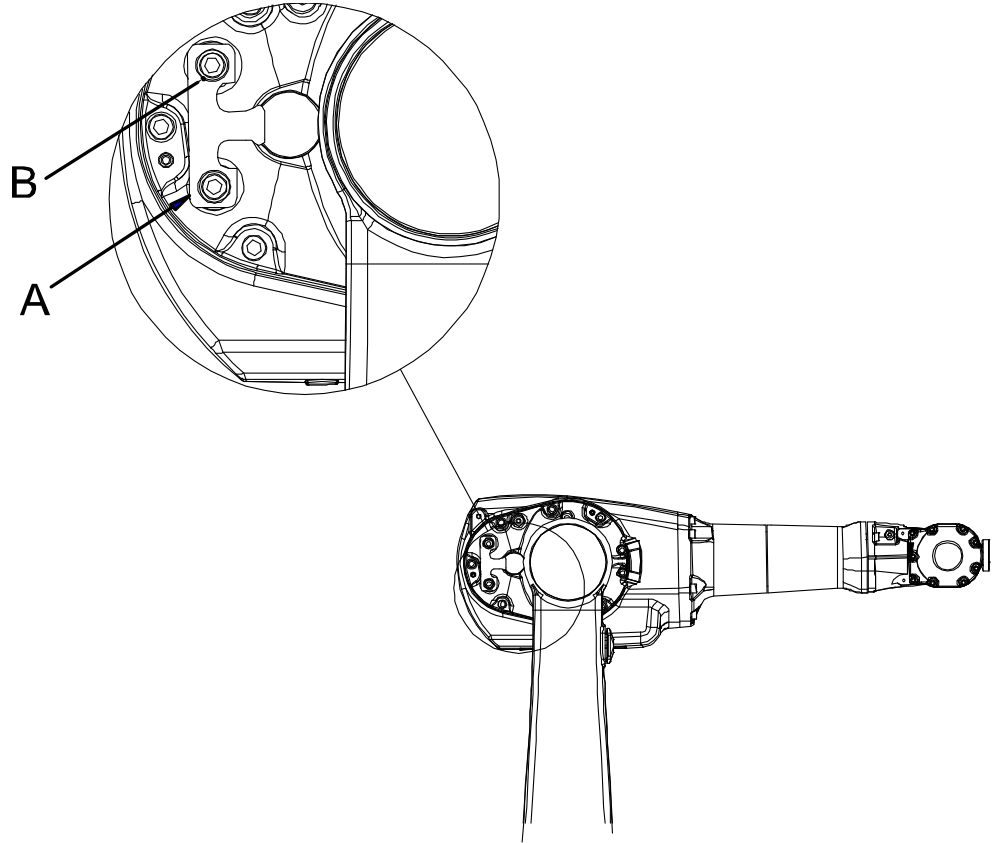

xx0400001285

A	Mechanical stop, axis 3
B	Attachment screws and washers (2 pcs)

#### Required equipment

Equipment	Art. no.	Note
Working range limit axis 3	3HAC026121-001	Includes mechanical stop, attachment screws and washers.
<i>Technical reference manual - System parameters</i>	-	Art. no. is specified in <a href="#">References on page 10</a> .

*Continues on next page*



## 2 Installation and commissioning

### 2.4.4 Installation of additional mechanical stops on axis 3

*Continued*

#### Installation of mechanical stop, axis 3

The procedure below details how to install the mechanical stop to axis 3.

	Action	Note
1	 <b>DANGER</b> Turn off all: <ul style="list-style-type: none"><li>• electric power supply</li><li>• hydraulic pressure supply</li><li>• air pressure supply</li></ul> to the robot, before entering the robot working area.	
2	Fit the mechanical stop to the two mounting holes at the upper arm housing, with the two attachment screws and washers. Tighten the screws.	See <i>Illustration, mechanical stop, axis 3 on page 111</i> . 2 pcs: M8 x 25, tightening torque: 25 Nm.
3	Adjust the software working range limitations (system parameter configuration) to correspond to the mechanical limitations.	The system parameters that must be changed ( <i>Upper joint bound</i> and <i>Lower joint bound</i> ) are described in <i>Technical reference manual - System parameters</i> .
4	 <b>WARNING</b> If the <i>mechanical stop pin</i> is deformed after a hard collision, it must be replaced! Deformed <i>movable stops</i> and/or <i>additional stops</i> as well as deformed <i>attachment screws</i> must also be replaced after a hard collision.	

#### 2.4.5 Installation of position switch, axis 1

##### General

This section details how to install the position switch to axis 1.

##### Location of position switch, axis 1

The position switch is installed between the frame and the base, as shown in the figure below.

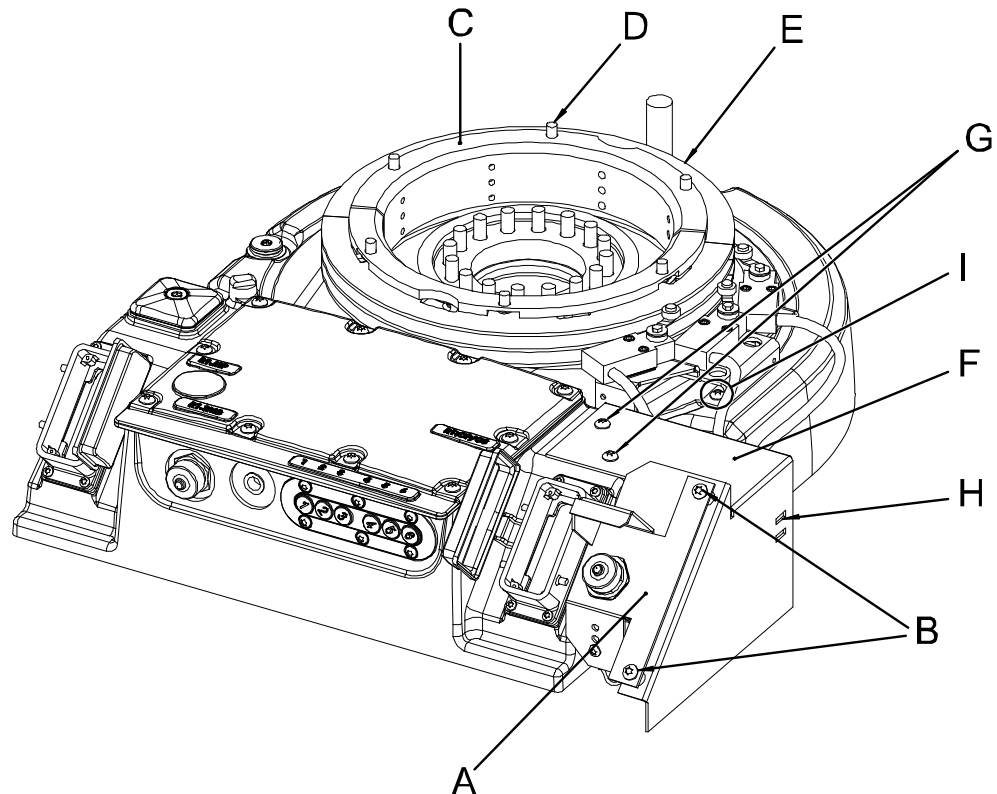

xx0400001356

A	Position switch
B	Attachment screws, position switch, 2 pcs: M6 x 30
C	Holder ring (2 parts)
D	Attachment screws, holder ring, 6 pcs: M8 x 12
E	Cam
F	Bracket
G	Attachment screws, housing, 2 pcs: M6 x 8
H	Cable straps
I	Attachment screws, attachment plate, 2 pcs: M6 x 16

*Continues on next page*

## 2 Installation and commissioning

### 2.4.5 Installation of position switch, axis 1

Continued

#### Required equipment

Equipment	Art. no.	Note
Position switch, axis 1	3HAC023973-001	Includes 3 switches. All parts are included in the delivery. Instruction of how to cut the cams is enclosed in the kit.
<i>Technical reference manual - System parameters</i>		Art. no. is specified in section <a href="#">References on page 10</a> .

#### Installation, position switch axis 1

The procedure below details how to install the position switch to the robot.

	Action	Note
1	 <b>DANGER</b> Turn off all: <ul style="list-style-type: none"><li>• electric power supply</li><li>• hydraulic pressure supply</li><li>• air pressure supply</li></ul> to the robot, before entering the robot working area.	
2	Fit the two <i>holder rings</i> underneath the frame with the six attachment screws.	Shown in the figure <a href="#">Location of position switch, axis 1 on page 113</a> . 6 pcs, M8 x 12.
3	Cut the <i>cams</i> according to instructions, enclosed with the position switch kit.	
4	Fit the <i>cams</i> to the holder ring with the attachment screws.	Shown in the figure <a href="#">Location of position switch, axis 1 on page 113</a> . M6 x 12.
5	Attach the position switch to the bracket with two attachment screws.	2 pcs, M6 x 30.
6	Fit the complete <i>bracket</i> to the base of the robot with the two attachment screws.	Shown in the figure <a href="#">Location of position switch, axis 1 on page 113</a> . 2 pcs, M6 x 8.

Continues on next page

## 2 Installation and commissioning

### 2.4.5 Installation of position switch, axis 1

Continued

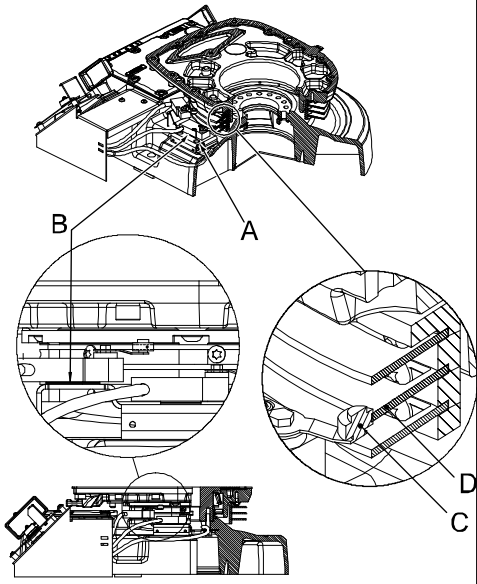
	Action	Note
7	<p>Fit the <i>attachment plate</i> to the base of the robot with the two attachment screws. Fit the switches to the attachment plate. Adjust the height of the switches with <i>shims</i> until each roller aligns with corresponding cam.</p>	<p>2 pcs, M6 x 16. Shown in the figure <a href="#">Location of position switch, axis 1 on page 113</a>.</p>  <p>xx0400001358</p> <p>A Attachment plate B Shims C Roller D Cam</p>
8	<p>Secure the cabling inside the housing with <i>cable straps</i>.</p>	<p>Shown in the figure <a href="#">Location of position switch, axis 1 on page 113</a>.</p>
9	<p>Connect the position switch cabling.</p>	<p>The cabling and connection points are specified in section <a href="#">Position switch cables, robot base to controller (option) on page 121</a>.</p>
10	<p>Adjust the software working range limitations (system parameter configuration) to correspond to the mechanical limitations.</p>	<p>The system parameters that must be changed (<i>Upper joint bound</i> and <i>Lower joint bound</i>) are described in <i>Technical reference manual - System parameters</i>.</p>

## 2 Installation and commissioning

### 2.5.1 Customer connectors on the robot

## 2.5 Electrical connections

### 2.5.1 Customer connectors on the robot

#### General

Customer connections are options, the cables for them are integrated in the robot and the connectors are placed on the upper arm housing.

The customer connections are:

- The standard connections for signals, power and air.
- The integrated wire feed cabling for signals and power.
- The 7-axis connection.



#### Note

No customer/application connections are available for IRB 1660ID.

#### Connections at robot base

The graphics below show the customer connections on the robot base. For description of all connection types see [Connection table on page 117](#).

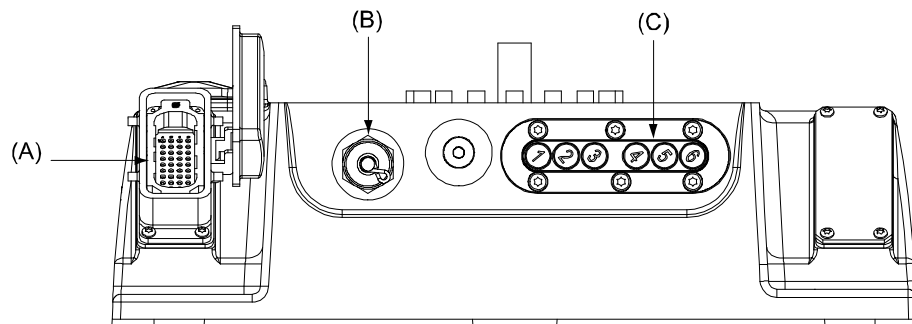

xx100000918

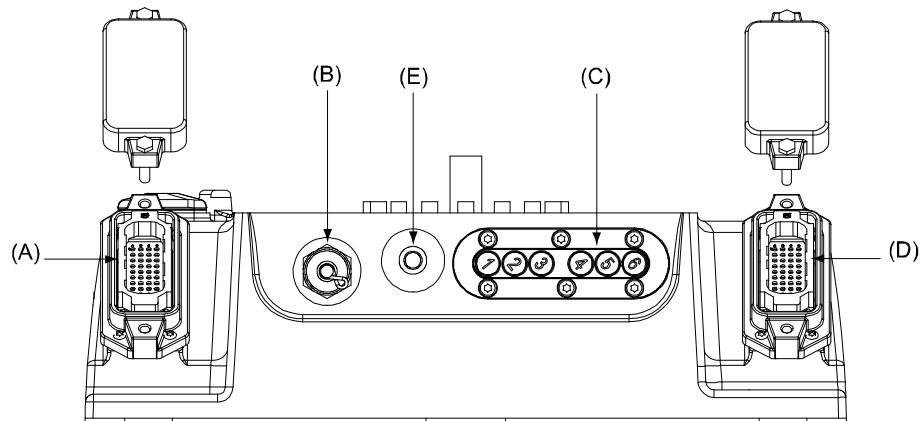

xx100000919

*Continues on next page*



## 2 Installation and commissioning

### 2.5.1 Customer connectors on the robot

*Continued*

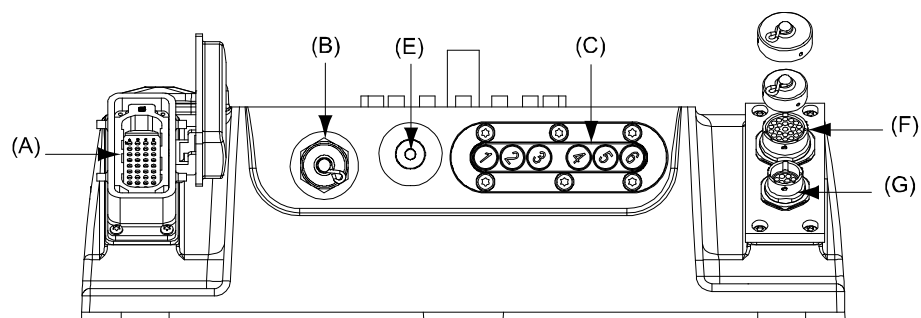

xx100000920

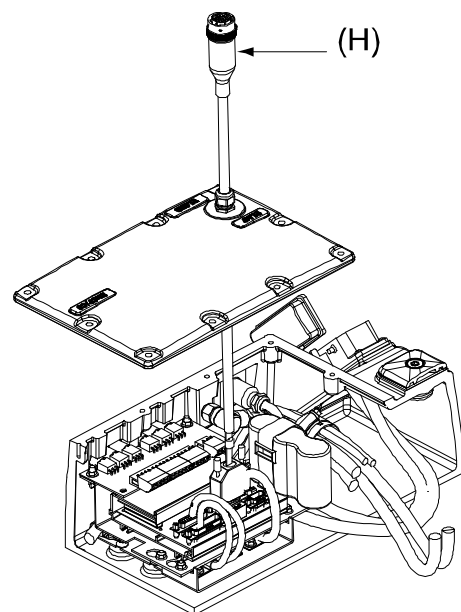

xx100000921

#### Connection table

Pos	Connection type	Description
A	R1.MP	Motor power
B	R1.SMB	Serial measurement board signal
C	-	Robot axes brake release buttons
D	R.1 CP/CS	Standard customer power and customer signal
E	R.1Air	Standard air
F	R1.CS	Customer signal for integrated wirefeed interface
G	R1.CP	Customer power for integrated wirefeed interface
H	R1.FB7	Axis 7 connection, 1.5 m cable

*Continues on next page*

## 2 Installation and commissioning

### 2.5.1 Customer connectors on the robot

Continued

#### Connections on upper arm

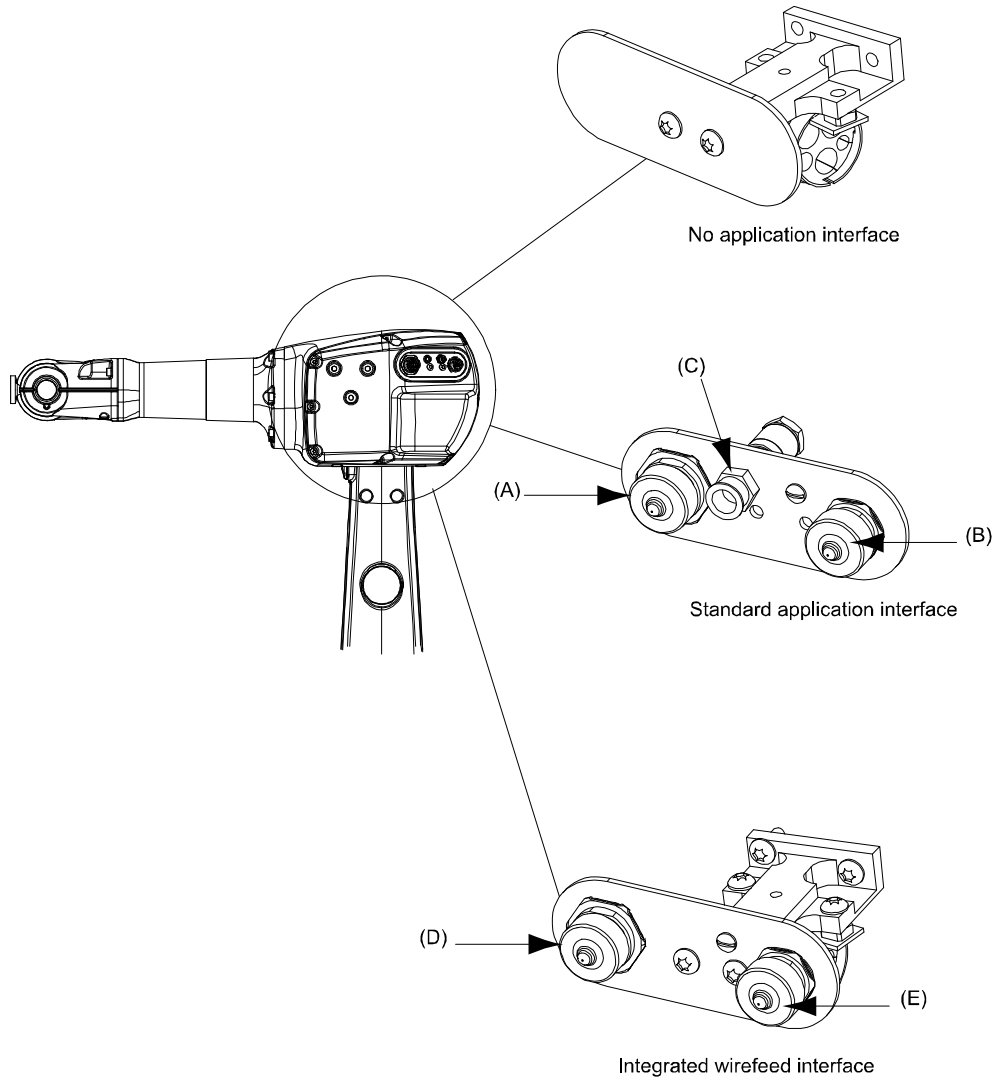

xx100000922

Pos	Connection type	Description
A	R2.CP	Standard customer power
B	R2.CS	Standard customer signal
C	R2.Air	Standard air
D	R2.CP	Customer power for integrated wirefeed interface
E	R2.CS	Customer signal for integrated wirefeed interface

## 2.5.2 Robot cabling and connection points

### Introduction

Connect the robot and controller to each other after securing them to the foundation. The lists below specify which cables to use for each respective application.

### Main cable categories

All cables between the robot and controller are divided into the following categories:

Cable category	Description
Robot cables	Handles power supply to and control of the robot's motors as well as feedback from the serial measurement board. Specified in the table <a href="#">Robot cables on page 119</a> .
Position switch cables (option)	Handles supply to and feedback from any position switch on the robot. Specified in the table <a href="#">Position switch cables, robot base to controller (option) on page 121</a> .
Customer cables (option)	Handles communication with equipment fitted on the robot by the customer, low voltage signals and high voltage power supply + protective ground. See the product manual for the controller, see document number in <a href="#">References on page 10</a> . Also specified in the table <a href="#">Customer cables (option) on page 121</a> .
External axes cables (option)	Handles power supply to and control of the external axes' motors as well as feedback from the servo system. See the <i>Application manual - Additional axes and stand alone controller (M2004)</i> , see document number in <a href="#">References on page 10</a> .

### Robot cables

These cables are included in the standard delivery. They are completely pre-manufactured and ready to plug in.

Cable sub-category	Description	Connection point, cabinet	Connection point, robot
Robot cable, power	Transfers drive power from the drive units in the control cabinet to the robot motors.	XS1	R1.MP
Robot cable, signals	Transfers resolver data from and power supply to the serial measurement board.	XS2	R1.SMB

### Robot cable, power, for robots with standard protection

Cable (standard)	Art. no.
Robot cable, power: 7 m	3HAC2492-1
Robot cable, power: 15 m	3HAC2529-1
Robot cable, power: 22 m	3HAC2539-1
Robot cable, power: 30 m	3HAC2564-1

*Continues on next page*

## 2 Installation and commissioning

### 2.5.2 Robot cabling and connection points

*Continued*

Robot cable, power, for robots with foundry and wash protection

Cable (foundry)	Art. no.
Robot cable, power: 7 m	3HAC9038-1
Robot cable, power: 15 m	3HAC9038-2
Robot cable, power: 22 m	3HAC9038-3
Robot cable, power: 30 m	3HAC9038-4

Robot cable, signals

Cable	Art. no.
Robot cable signal, shielded: 7 m	3HAC2493-1
Robot cable signal, shielded: 15 m	3HAC2530-1
Robot cable signal, shielded: 22 m	3HAC2540-1
Robot cable signal, shielded: 30 m	3HAC2566-1

### Bending radius for static floor cables

The minimum bending radius is 10 times the cable diameter for static floor cables.

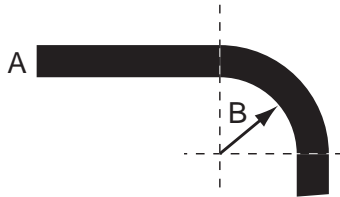

xx1600002016

A	Diameter
B	Diameter x10

*Continues on next page*

#### Grounding and bonding point on manipulator

There is a grounding/bonding point on the manipulator base. The grounding/bonding point is used for potential equalizing between control cabinet, manipulator and any peripheral devices.

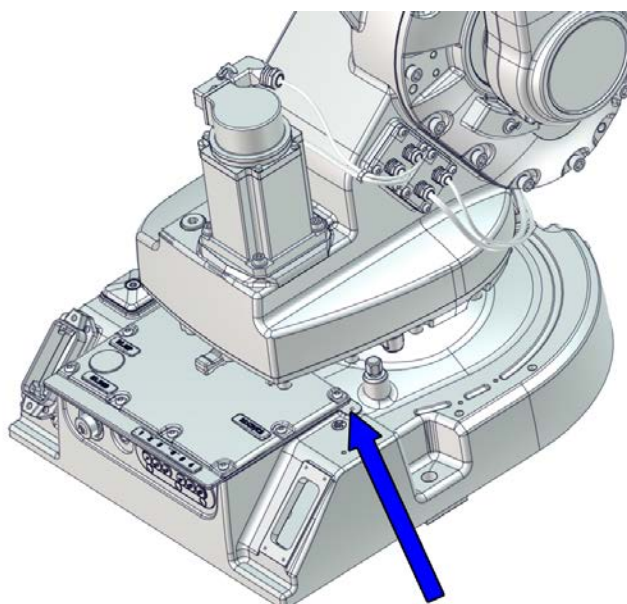

xx170000097

#### Position switch cables, robot base to controller (option)

The cable is delivered in one length only and should be wound to suitable length.

#### Cabling between robot base and controller

Cable	Art. no.	Connection point, robot	Connection point, cabinet
Position switch cable, axis 1, 30 m	3HAC7997-4	R1.LS	XS8

#### Customer cables (option)

The customer cables specified below are connected between robot and controller.

The customer cables are ordered according to current protection class of the robot.

#### Customer cables for robots with standard protection

Cable (standard)	Art. no.	Connection point, robot
Customer cable, power-signal, 7 m	3HAC3353-1	R1.CP/CS
Customer cable, power-signal, 15 m	3HAC3354-1	R1.CP/CS
Customer cable, power-signal, 22 m	3HAC3355-1	R1.CP/CS
Customer cable, power-signal, 30 m	3HAC3356-1	R1.CP/CS

*Continues on next page*

## 2 Installation and commissioning

---

### 2.5.2 Robot cabling and connection points

*Continued*

Customer cables for robots with foundry and wash protection

Cable (Foundry, Wash)	Art. no.	Connection point, robot
Customer cable, power-signal, 7 m	3HAC8183-1	R1.CP/CS
Customer cable, power-signal, 15 m	3HAC8183-2	R1.CP/CS
Customer cable, power-signal, 22 m	3HAC8183-3	R1.CP/CS
Customer cable, power-signal, 30 m	3HAC8183-4	R1.CP/CS

### 2.5.3 Customer connections on the robot

#### General

For connection of equipment on the robot, there are cables integrated into the robot cabling. This section specifies recommendations for the customer connections.

The air and electrical connectors are shown in the figure [Customer connectors on the robot on page 116](#).

#### Air connection

Connection	Dimension
Air inlet (at the base)	
Air outlet (at the upper arm housing)	1/4"

The integrated air hose is sized as specified in the table below.

Inner diameter	Max. pressure
8 mm	0.8 MPa / 115 psi

#### Customer connectors R2.CS and R2.CP

The customer connectors R2.CS and R2.CP can be used with either:

- a connector set from ABB for standard connection
- specified connector components from Souriau, or
- connectors that meet Military standard MIL-C-26482 series 1.

These connectors are further detailed in following sections.

#### Connector set from ABB for standard connection

Equipment	ABB art. no.	Note
Connection set R2.CP/R2.CS	3HAC025396-001	Only for standard connection.

*Continues on next page*

## 2 Installation and commissioning

### 2.5.3 Customer connections on the robot

Continued

#### Specified connector components from Souriau

The components specified below are from connector manufacturer Souriau and can be used for connection to R2.CS and R2.CP.

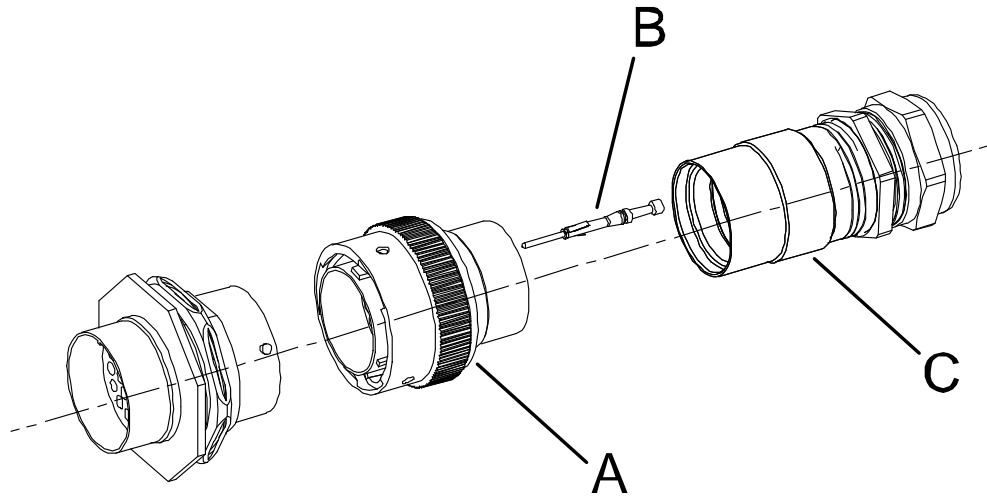

xx0400001339

A	Pin connector
B	Pin
C	Backshell

#### Recommended pin connectors

Pin connector	Souriau art. no.
Pin connector, standard connection, CS (Customer Signal)	UT0W6 1626 P-H
Pin connector, standard connection, CP (Customer Power)	UT0W6 1210 P-H
Pin connector, integrated wirefeeder cabling, CS	UT0W6 1626 P-H
Pin connector, Integrated wirefeeder cabling, CP	UT06 1412 P-H04

#### Recommended pins (turned)

Turned pins for cable area...	Pin diameter	Souriau art. no.
0.21 - 0.93 mm <sup>2</sup> (standard connection, CP/CS and integrated wirefeeder cabling, CS)	1 mm	RM18W3K
0.13 - 0.25 mm <sup>2</sup> (integrated wirefeeder cabling, CP)	1.6 mm	RM24M9K
0.25 - 0.5 mm <sup>2</sup> (integrated wirefeeder cabling, CP)	1.6 mm	RM20M12K
0.5 - 1.5 mm <sup>2</sup> (integrated wirefeeder cabling, CP)	1.6 mm	RM16M23K

#### Recommended backshell

Backshell	Souriau art. no.
Backshell, standard connection, CS	UT0 16JC
Backshell, standard connection, CP	UT0 12JC
Backshell, integrated wirefeeder cabling, CS	UT0 16JC
Backshell, integrated wirefeeder cabling, CP	UT0 14JC

Continues on next page



#### Connectors that meet Military standard

The connectors specified below meet Military standard MIL-C-26482 series 1 and can be used for connection to R2.CS and R2.CP (only for standard customer connection).

The figure below shows a complete connector, including pin connector and backshell.

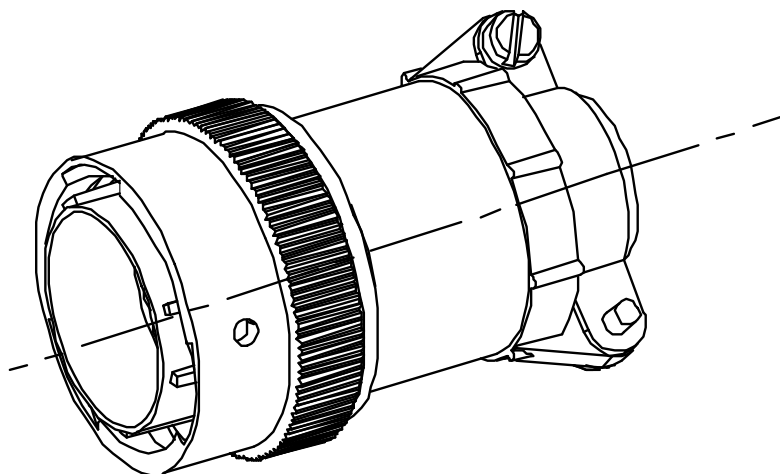

xx0400001340

#### Connector for crimping

The complete pin connectors for crimping include pin connector and backshell.

Connector for crimping	Military standard MIL-C-26482
Complete pin connector, CS	MS3126*1626S
Complete pin connector, CP	MS3126*1210S
Turned pin 0.2 - 0.5 mm <sup>2</sup>	M39029/31-240
Turned pin 0.5 - 1.5 mm <sup>2</sup>	M29029/31-228

#### Connector for soldering

The complete pin connectors for soldering include pin connector, backshell and pins.

Connector for soldering	Military standard MIL-C-26482
Complete pin connector, CS	MS3116*1626S
Complete pin connector, CP	MS3116*1210S

## 2 Installation and commissioning

### 2.6 Start of robot in cold environments

### 2.6 Start of robot in cold environments

#### Introduction

This section describes how to start the robot in a cold environment if it is not starting the normal way.

#### Problems with starting the robot

##### Event message from Motion Supervision

Use this procedure if an event message indicates a problem with Motion supervision at start-up. More information about Motion Supervision is found in *Technical reference manual - System parameters*.

	Action	Note
1	Turn off Motion Supervision.	
2	Start the robot.	
3	When the robot has reached normal working temperature, the Motion Supervision can be turned on again.	

##### Robot stopping with other event message

Use this procedure if the robot is not starting.

	Action	Note
1	Start the robot with its normal program but with reduced speed.	The speed can be regulated with the RAPID instruction <code>VelSet</code> .

#### Adjusting the speed and acceleration during warm-up

Depending on how cold the environment is and what program is being used, the speed might need to be ramped up until reached maximum. The table shows examples of how to adjust the speed:

Work cycles	AccSet	Speed/velocity
3 Work cycles	20, 20	v100 (100 mm/s)
5 Work cycles	40, 40	v400 (400 mm/s)
5 Work cycles	60, 60	v600 (600 mm/s)
5 Work cycles	100, 100	v1000 (1000 mm/s)
More than 5 Work cycles	100, 100	Max.

If the program consists of large wrist movements, it is possible that the reorientation velocity, which is always high in predefined velocities, needs to be included in the ramping up.

---

## 3 Maintenance

### 3.1 Introduction

---

#### Structure of this chapter

This chapter describes all the maintenance activities recommended for the IRB 1600/1660ID.

It is based on the maintenance schedule found at the beginning of the chapter. The schedule contains information about required maintenance activities including intervals, and refers to procedures for the activities.

Each procedure contains all the information required to perform the activity, including required tools and materials.

The procedures are gathered in different sections and divided according to the maintenance activity.

---

#### Safety information

Observe all safety information before conducting any service work.

There are general safety aspects that must be read through, as well as more specific safety information that describes the danger and safety risks when performing the procedures. Read the chapter [Safety on page 19](#) before performing any service work.

**Note**

If the IRB 1600/1660ID is connected to power, always make sure that the IRB 1600/1660ID is connected to protective earth before starting any maintenance work.

For more information see:

- *Product manual - IRC5*

## 3 Maintenance

---

### 3.2.1 Specification of maintenance intervals

## 3.2 Maintenance schedule and expected component life

### 3.2.1 Specification of maintenance intervals

---

#### Introduction

The intervals are specified in different ways depending on the type of maintenance activity to be carried out and the working conditions of the IRB 1600/1660ID:

- Calendar time: specified in months regardless of whether the system is running or not.
- Operating time: specified in operating hours. More frequent running means more frequent maintenance activities.
- SIS: specified by the robot's SIS (Service Information System). A typical value is given for a typical work cycle, but the value will differ depending on how hard each part is run. The SIS used in M2004 is further described in the *Operating manual - Service Information System*.

### 3.2.2 Maintenance schedule

#### General

The robot must be maintained regularly to ensure proper function. The maintenance activities and intervals are specified in the table below.

Unexpected situations that arise prompt inspection of the robot. Any damage must be attended to immediately!

The inspection intervals *do not* specify the life of each component.

#### Maintenance schedule

The table below specifies the required maintenance activities and intervals:

Maintenance activity	Equipment	Interval	Detailed in section
Maintenance free	Gearbox oil, axes 1 to 4 IRB 1600	40,000 hrs	
Inspection	Information labels	12 months	Replace any damaged, missing or unreadable labels. <a href="#">Inspecting information labels on page 135</a>
Changing	Gearbox oil, axes 5 and 6 IRB 1600	20,000 hrs	<a href="#">Changing the oil in axes 5 and 6 gearboxes on page 138.</a>
Changing	Gearbox oil, axes 5-6 IRB 1600ID-4/1.5	20,000 hrs	<a href="#">Changing the oil in axes 5 and axis 5 and 6 gearboxes, IRB 1600ID/1660ID on page 141</a>
Changing	Gearbox oil, axes 5-6 IRB 1660ID-X/1.55	20,000 hrs	<a href="#">Changing the oil in axes 5 and axis 5 and 6 gearboxes, IRB 1600ID/1660ID on page 141</a>
Replacement	Battery pack, measurement system of type RMU101 or RMU102 (3-pole battery contact)	36 months or battery low alert <sup>i</sup>	<a href="#">Replacing the battery pack on page 144</a>
Replacement	Battery pack, measurement system with 2-pole battery contact, e.g. DSQC633A	Battery low alert <sup>ii</sup>	<a href="#">Replacing the battery pack on page 144.</a>
Cleaning	Complete robot	Regular <sup>iii</sup>	<a href="#">Cleaning the IRB 1600/1660ID on page 149</a>

<sup>i</sup> The battery low alert (38213 **Battery charge low**) is displayed when the battery needs to be replaced. The recommendation to avoid an unsynchronized robot is to keep the power to the controller turned on until the battery is to be replaced.

See the replacement instruction for more details.

<sup>ii</sup> The battery low alert (38213 **Battery charge low**) is displayed when remaining backup capacity (robot powered off) is less than 2 months. The typical lifetime of a new battery is 36 months if the robot is powered off 2 days/week or 18 months if the robot is powered off 16 h/day. The lifetime can be extended with a battery shutdown service routine. See *Operating manual - IRC5 with FlexPendant* for instructions.

*Continues on next page*

## 3 Maintenance

---

### 3.2.2 Maintenance schedule

*Continued*

- iii A regular interval implies that the activity is to be performed regularly, but the actual interval may not be specified by the robot manufacturer. The interval depends on the operation cycle of the robot, its working environment and movement pattern. Generally, the more contaminated environment, the closer the intervals. The more demanding movement pattern (sharper bending cable harness), the closer the intervals.

### 3.2.3 Expected component life

#### General

The life of any component depends on how hard it is run, and it can vary greatly.

#### Expected component life

Component	Expected life	Note
Robot cable harness IRB 1600	2,000,000 cycles	See note <sup>i</sup>
Robot cable harness IRB 1600ID-4/1.5	2,000,000 cycles	See note <sup>i</sup>
Robot cable harness IRB 1660ID-X/1.55	2,000,000 cycles	See note <sup>i</sup>
Cabling for position switch	2,000,000 cycles	See note <sup>i</sup>
Gearbox	40,000 hrs	

<sup>i</sup> The expected life can also be affected by grouping harnesses/cables other than standard options. The life expectancy is based on a test cycle that for every axis goes from the calibration position to minimum angle, to maximum angle and back to the calibration position. Deviations from this test cycle will result in differences in expected life!

## 3 Maintenance

---

### 3.3.1 Inspection, damper axes 2, 3 and 5

## 3.3 Inspection activities

### 3.3.1 Inspection, damper axes 2, 3 and 5

---

#### Location of dampers

The figure below shows the location of all the dampers to be inspected.

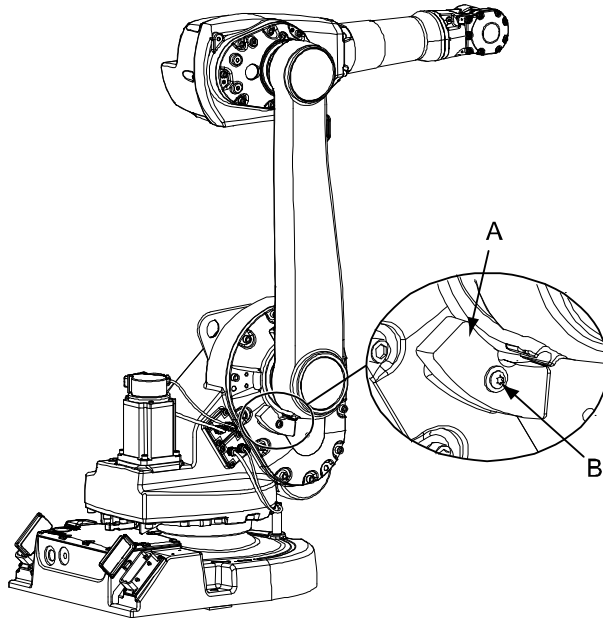

xx0400001217

A	Damper, axis 2
B	Attachment screw

*Continues on next page*



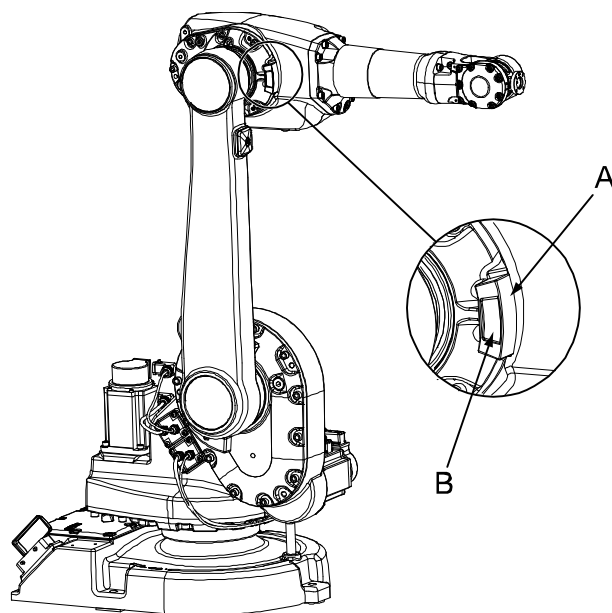

xx0400001215

A	Damper, axis 3
B	Cast tab

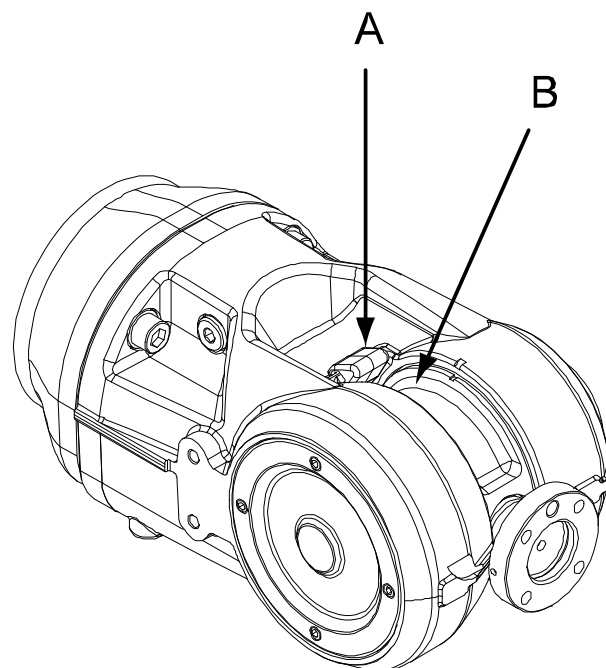

xx0600002806

A	Damper, axis 5
B	Recess

## 3 Maintenance

### 3.3.1 Inspection, damper axes 2, 3 and 5

*Continued*

#### Required equipment

Equipment	Art. no.	Note
Standard toolkit	-	Content is defined in section <a href="#">Standard tools on page 383</a> .



#### CAUTION

Always cut the paint with a knife and grind the paint edge when disassembling parts. See [Cut the paint or surface on the robot before replacing parts on page 159](#).

#### Inspection, dampers

The procedure below details how to inspect the dampers.

	Action	Note
1	 <b>DANGER</b> Turn off all: <ul style="list-style-type: none"><li>• electric power supply</li><li>• hydraulic pressure supply</li><li>• air pressure supply</li></ul> to the robot, before entering the robot working area.	
2	Check all <i>dampers</i> for damage, such as cracks or existing impressions that are larger than 1 mm.	Shown in the figure <a href="#">Location of dampers on page 132</a> .
3	Check attachment screws for deformation.	
4	If any damage is detected, the damper must be replaced with a new one!	Replacement is detailed in sections: <ul style="list-style-type: none"><li>• <a href="#">Replacing the damper, axis 2 on page 220</a></li><li>• <a href="#">Replacing the damper, axis 3 on page 222</a></li><li>• <a href="#">Replacement of damper, axis 5 on page 226</a>.</li></ul>

3.3.2 Inspecting information labels

Location of information labels

The figure shows the location of the information labels to be inspected.

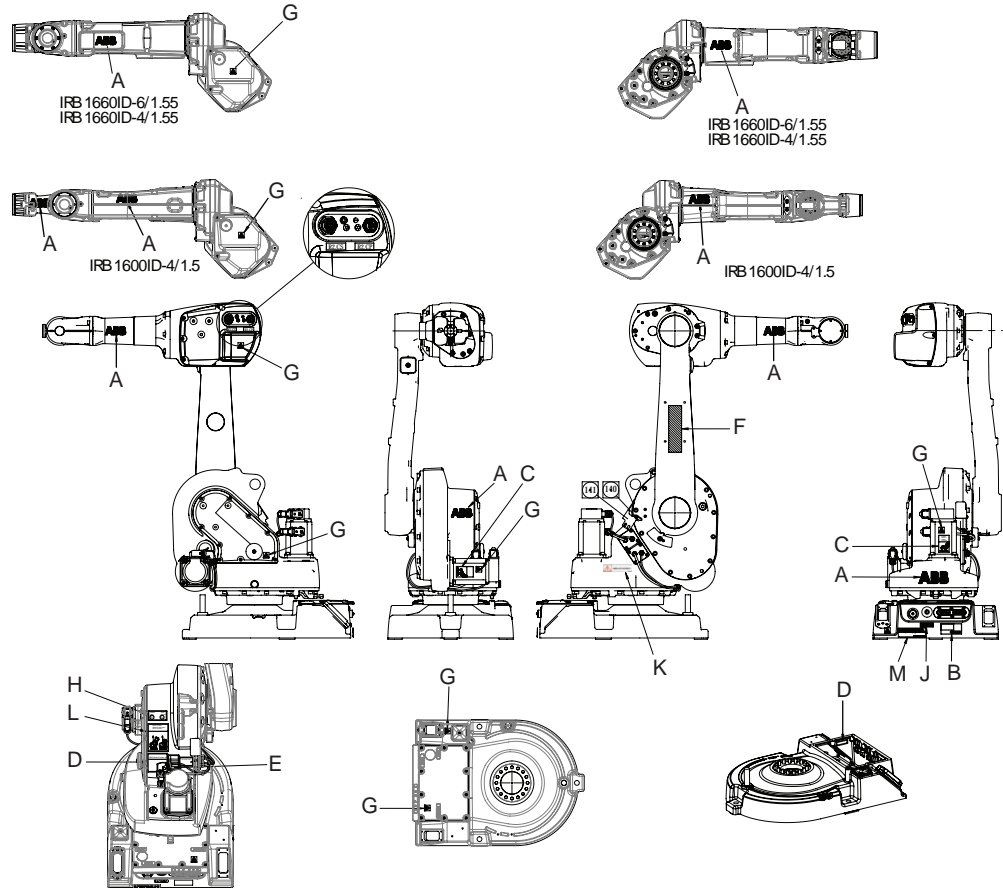

xx1800001187

A	ABB logotype
B	Warning label - Brake release
C	Warning label - heat (2 pcs)
D	Rating label
E	Calibration label
F	Foundry Plus or CleanRoom logotype, if applicable.
G	Warning label - Electricity (symbol of flash) (6 pcs)
H	UL label
J	Label - Max. air pressure
K	Information sign - AbsAcc
L	Lifting instruction label
M	Oil label

Continues on next page

## 3 Maintenance

### 3.3.2 Inspecting information labels

*Continued*

#### Required equipment

Equipment	Spare part number	Note
Labels	See <a href="#">Spare part lists on page 387</a> .	

#### Inspecting labels

Use this procedure to inspect the labels on the robot.

	Action	Note
1	 <b>DANGER</b> Turn off all: <ul style="list-style-type: none"><li>• electric power supply</li><li>• hydraulic pressure supply</li><li>• air pressure supply</li></ul> to the robot, before entering the robot working area.	
2	Check all labels.	See the figure in <a href="#">Location of information labels on page 135</a> .
3	Replace any missing or damaged labels.	

## 3.4 Replacement activities

### 3.4.1 Type of lubrication in gearboxes

#### Introduction

This section describes where to find information about the *type of lubrication*, *article number* and the *amount of lubrication* in the specific gearbox. It also describes the equipment needed when working with lubrication.

#### Type and amount of oil in gearboxes

Information about the *type of lubrication*, *article number* as well as the *amount* in the specific gearbox can be found in *Technical reference manual - Lubrication in gearboxes* available for registered users on myABB Business Portal, [www.myportal.abb.com](http://www.myportal.abb.com).

Before starting any inspection, maintenance, or changing activities of lubrication, **always** contact the local ABB Service organization for more information.

For ABB personnel: Always check ABB Library for the latest revision of the manual *Technical reference manual - Lubrication in gearboxes*, in order to always get the latest information of updates about lubrication in gearboxes. A new revision will be published on ABB Library immediately after updates.

#### Location of gearboxes

The figure shows the location of the gearboxes.

#### Equipment

Equipment	Note
Oil dispenser	Includes pump with outlet pipe. Use the suggested dispenser or a similar one: <ul style="list-style-type: none"> <li>Orion OriCan article number 22590 (pneumatic)</li> </ul>
Nipple for quick connect fitting, with o-ring	
Expansion container, gearbox axis 1	Used when the robot is fitted in a suspended position.

## 3 Maintenance

### 3.4.2 Changing the oil in axes 5 and 6 gearboxes

### 3.4.2 Changing the oil in axes 5 and 6 gearboxes

#### Location of oil plugs

The gearboxes for axes 5 and 6 are located in the wrist unit as shown in the figure below.

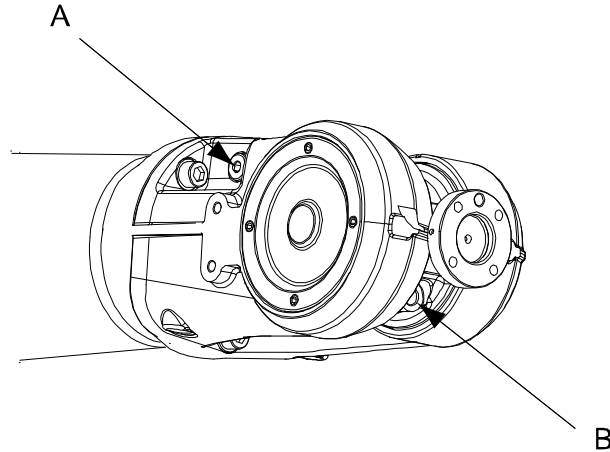

xx0600002846

A	Oil plug, draining and filling
B	Oil plug, vent hole

#### Required equipment

Equipment, etc.	Note
Lubricating oil	Information about the oil is found in <i>Technical reference manual - Lubrication in gearboxes</i> . See <a href="#">Type and amount of oil in gearboxes on page 137</a> .
Oil collecting vessel	The capacity of the vessel must be sufficient to take the complete amount of oil.
Standard toolkit	Content is defined in section <a href="#">Standard tools on page 383</a> .
Other tools and procedures may be required. See references to these procedures in the step-by-step instructions below.	These procedures include references to the tools required.





#### CAUTION

Always cut the paint with a knife and grind the paint edge when disassembling parts. See [Cut the paint or surface on the robot before replacing parts on page 159](#).

*Continues on next page*

#### Draining, wrist unit

The procedure below details how to drain oil from the gearboxes in the wrist unit.

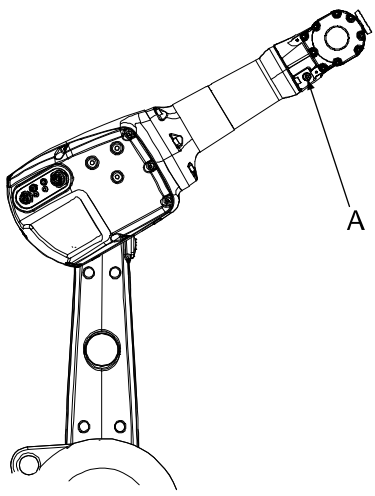
	Action	Note/Illustration
1	 <p><b>DANGER</b></p> <p>Turn off all:</p> <ul style="list-style-type: none"> <li>• electric power supply</li> <li>• hydraulic pressure supply</li> <li>• air pressure supply</li> </ul> <p>to the robot, before entering the robot working area.</p>	
2	 <p><b>WARNING</b></p> <p>Handling gearbox oil involves several safety risks. Before proceeding, please read the safety information in the section <i>Safety risks during work with gearbox lubricants (oil or grease) on page 38</i>.</p>	
3	<p>Position the robot as shown in the figure to the right:</p> <ul style="list-style-type: none"> <li>• upper arm: upwards for a standing robot</li> <li>• axis 4: 180°, to a position where the oil plug (A), faces downwards.</li> </ul> <p><b>Note!</b> The total amount of oil will not be drained. There will remain approximately 50 ml in the wrist unit.</p>	<p>The capacity of the vessel must be sufficient to take the complete amount of oil.</p>  <p>xx0500001434</p> <p>A Oil plug, draining and filling The position for an <i>inverted</i> robot is the opposite!</p>
4	<p>Remove the both <i>oil plugs</i>. Both oil plugs must be removed in order to drain the wrist unit properly.</p>	<p>Shown in the figure <i>Location of oil plugs on page 138</i>.</p>
5	<p>Refit the oil plug, vent hole.</p>	

Continues on next page



### 3 Maintenance

#### 3.4.2 Changing the oil in axes 5 and 6 gearboxes

*Continued*

#### Filling oil, wrist unit

The procedure below details how to fill oil in the gearboxes in the wrist unit.

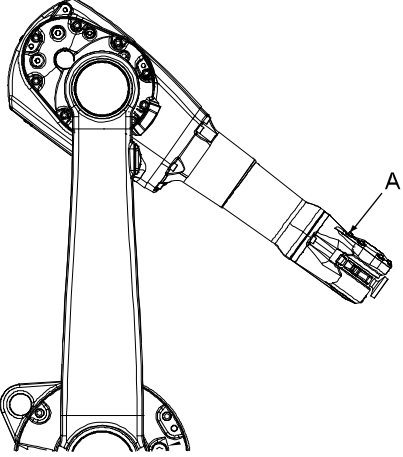
	Action	Note/Illustration
1	 <p><b>DANGER</b></p> <p>Turn off all:</p> <ul style="list-style-type: none"> <li>• electric power supply</li> <li>• hydraulic pressure supply</li> <li>• air pressure supply</li> </ul> <p>to the robot, before entering the robot working area.</p>	
2	 <p><b>WARNING</b></p> <p>Handling gearbox oil involves several safety risks. Before proceeding, please read the safety information in the section <a href="#">Safety risks during work with gearbox lubricants (oil or grease) on page 38</a>.</p>	
3	Remove the <i>oil plug, draining and filling</i> .	Shown in the figure <a href="#">Location of oil plugs on page 138</a> !
4	<p>Position the robot as shown in the figure to the right:</p> <ul style="list-style-type: none"> <li>• upper arm: downwards for a standing robot</li> <li>• axis 4: 90°, to a position where the oil plug (A), faces upwards.</li> </ul> <p>Fill oil in the wrist unit through the oil plug.</p>	<p>Where to find type of oil and total amount is detailed in <a href="#">Type and amount of oil in gearboxes on page 137</a>.</p>  <p>xx0500001435</p> <ul style="list-style-type: none"> <li>• A: Oil plug, draining and filling</li> </ul> <p>The position for an <i>inverted robot</i> is the opposite.</p>
5	Refit the oil plug.	



## 3.4.3 Changing the oil in axes 5 and axis 5 and 6 gearboxes, IRB 1600ID/1660ID

## 3.4.3 Changing the oil in axes 5 and axis 5 and 6 gearboxes, IRB 1600ID/1660ID

## Location of oil plugs, axis 5-6 gearbox

The oil plugs for the axis 5 and axis 5-6 gearbox are located in the wrist unit as shown in the figure below.

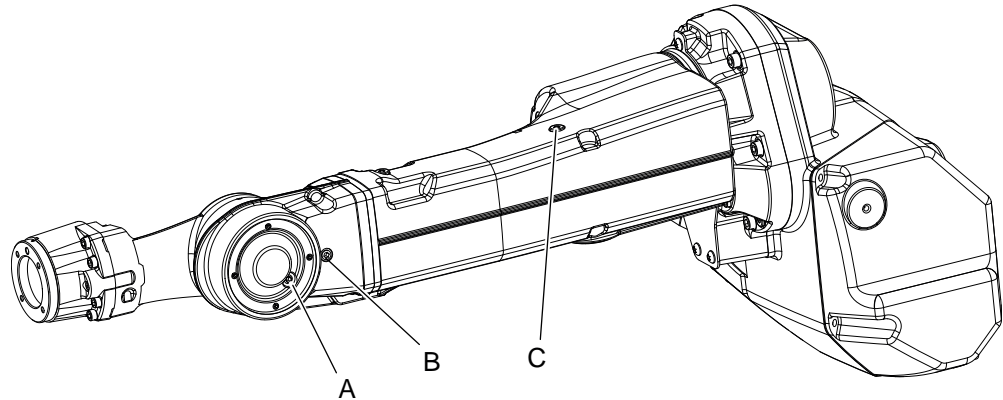

xx070000030

A	Oil plug, draining and filling, axis 5-6
B	Oil plug, draining ventilation plug, axis 5-6
C	Oil plug, draining and filling, axis 5

## Required equipment

Equipment	Note
Lubricating oil	Information about the oil is found in <i>Technical reference manual - Lubrication in gearboxes</i> . See <a href="#">Type and amount of oil in gearboxes on page 137</a> .
Oil collecting vessel	The capacity of the vessel must be sufficient to take the complete amount of oil.
Standard toolkit	Content is defined in section <a href="#">Standard tools on page 383</a> .
Other tools and procedures may be required.	See references to these procedures in the step-by-step instructions below.

**CAUTION**

Always cut the paint with a knife and grind the paint edge when disassembling parts. See [Cut the paint or surface on the robot before replacing parts on page 159](#).

Continues on next page





### 3 Maintenance

#### 3.4.3 Changing the oil in axes 5 and axis 5 and 6 gearboxes, IRB 1600ID/1660ID

Continued

#### Draining, axis 5-6 gearbox

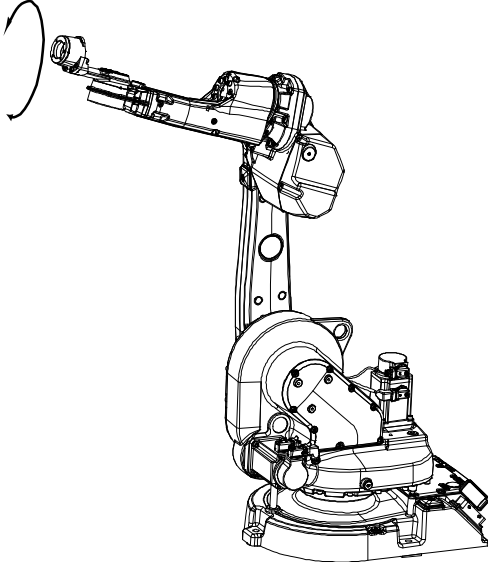
Use this procedure to drain the axis 5-6 gearbox.

	Action	Note
1	 <b>DANGER</b> Turn off all: <ul style="list-style-type: none"> <li>• electric power supply</li> <li>• hydraulic pressure supply</li> <li>• air pressure supply</li> </ul> to the robot, before entering the robot working area.	
2	 <b>WARNING</b> Handling gearbox oil involves several safety risks. Before proceeding, please observe the safety information in section <i>Safety risks during work with gearbox lubricants (oil or grease) on page 38</i> .	
3	Position the robot as shown in the figure to the right: <ul style="list-style-type: none"> <li>• upper arm: upwards for a standing robot.</li> <li>• axis 4: - 90°, to a position where the oil plug (A) is faced downwards.</li> </ul>  <b>Note</b> The total amount of oil will not be drained. There will remain approximately 20 ml in the wrist unit.	The capacity of the vessel must be sufficient to take the complete amount of oil.   xx0700000033
4	 <b>CAUTION</b> The gearbox can contain an <i>excess of pressure</i> that can be hazardous. Open the oil plug carefully in order to let out the excess pressure.	
5	Remove the oil plug (A) and the ventilation plug (B).	Shown in figure <i>Location of oil plugs, axis 5-6 gearbox on page 141</i> .

Continues on next page

#### 3.4.3 Changing the oil in axes 5 and axis 5 and 6 gearboxes, IRB 1600ID/1660ID

*Continued*

	Action	Note
6	Drain the wrist of oil.	The quantity of the oil: <ul style="list-style-type: none"> <li>• 1660ID: About 240 ml</li> <li>• 1600ID: About 100 ml</li> </ul>
7	Remove the oil plug (C).	Shown in figure <a href="#">Location of oil plugs, axis 5-6 gearbox on page 141</a> .
8	Drain the oil from the wrist.	The quantity of the oil: <ul style="list-style-type: none"> <li>• 1660ID: About 15 ml</li> <li>• 1600ID: About 10 ml</li> </ul>
9	Refit the oil plugs.	Tightening torque: 3 Nm.

#### Filling oil, axis 5-6 gearbox

Use this procedure to fill the axis 5-6 gearbox with oil.

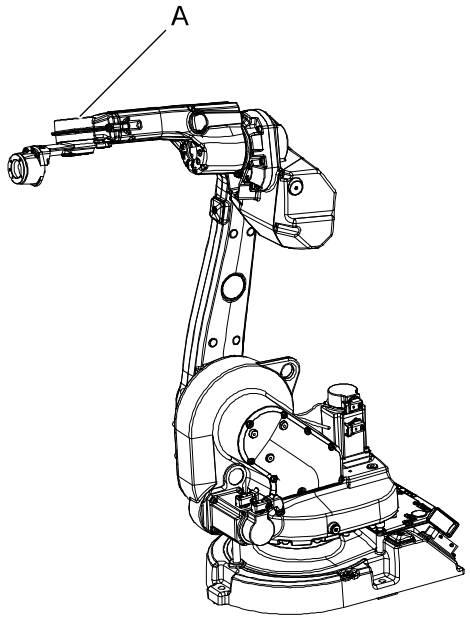
	Action	Note
1	Position the robot as shown in the figure to the right: <ul style="list-style-type: none"> <li>• axis 4: + 90°, to a position where the oil plug (A) is faced upwards.</li> </ul>	 <p>xx0700000034</p> <p>A Oil plugs</p>
2	Fill new oil in the wrist. Check the oil level to make sure the filled amount of oil is correct.	Where to find type of oil and total amount is detailed in <a href="#">Type and amount of oil in gearboxes on page 137</a> .
3	Refit the oil plug and the ventilation plug.	Tightening torque: 3 Nm.

## 3 Maintenance

### 3.4.4 Replacing the battery pack

#### 3.4.4 Replacing the battery pack



#### Note

The battery low alert (38213 **Battery charge low**) is displayed when the battery needs to be replaced. The recommendation to avoid an unsynchronized robot is to keep the power to the controller turned on until the battery is to be replaced. For an SMB board with 3-pole battery contact (RMU101 3HAC044168-001 or RMU102 3HAC043904-001), the lifetime of a new battery is typically 36 months. For an SMB board with 2-pole battery contact, the typical lifetime of a new battery is 36 months if the robot is powered off 2 days/week or 18 months if the robot is powered off 16 h/day. The lifetime can be extended for longer production breaks with a battery shutdown service routine. See *Operating manual - IRC5 with FlexPendant* for instructions.



#### WARNING

See instructions for batteries, [Safety risks during handling of batteries on page 37](#).

#### Location of battery pack

The battery pack for the measurement system is located inside the base of the robot, as shown in the figure below.

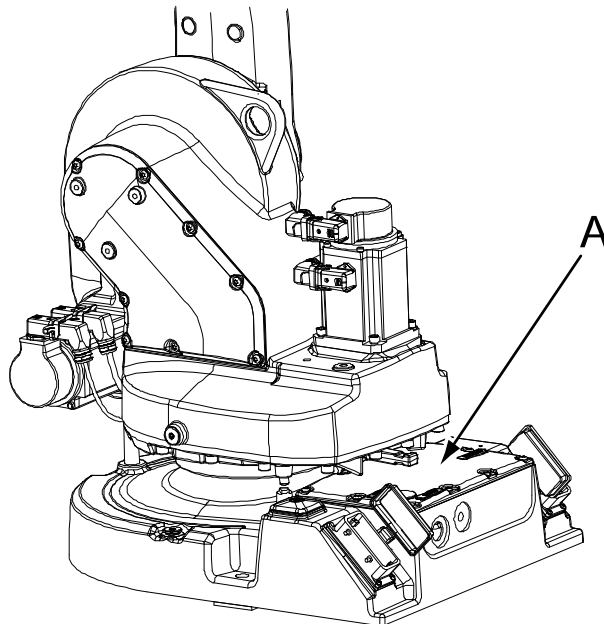

xx0500001390

A	Base cover, including gasket. Battery pack is located beneath the cover.
---	--

*Continues on next page*

#### Battery pack on serial measurement unit

The battery pack is attached to the serial measurement unit as shown in the figure below.

DSQC 633A

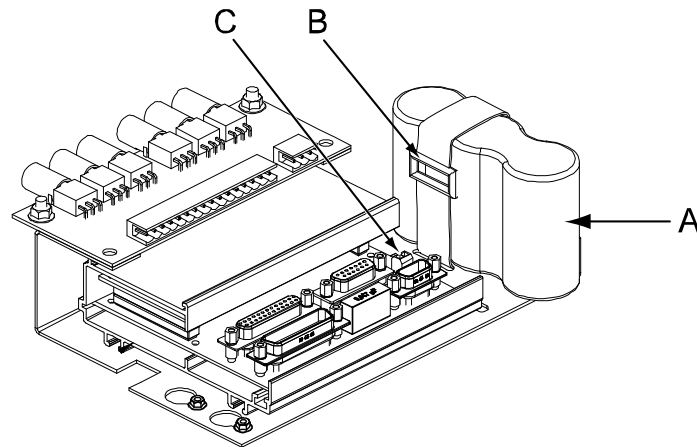

xx0500001393

A	Battery pack battery (2-pole battery contact)
B	Velcro strap
C	Connector X3

*Continues on next page*

### 3 Maintenance

#### 3.4.4 Replacing the battery pack

Continued

RMU 101

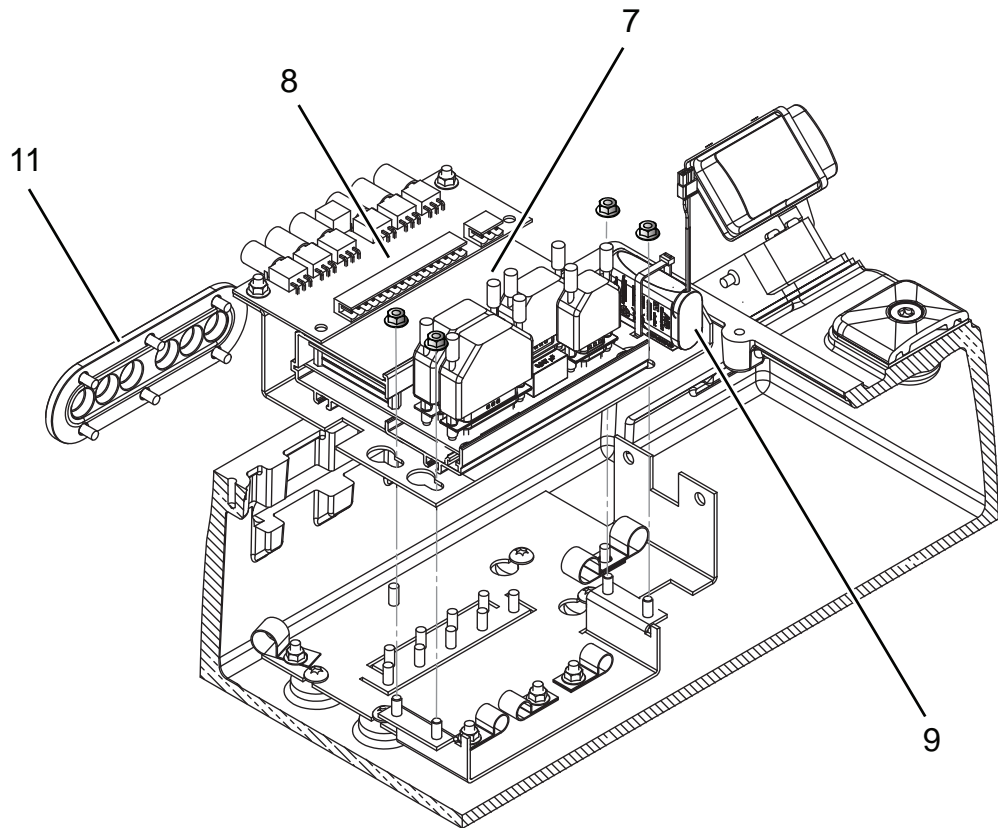

xx1300000332

7	Serial measurement board RMU 101
8	BU unit
9	Battery pack (3-pole battery contact)
10	Push button guard

#### Required equipment



#### Note

There are two variants of SMB units and batteries. One with 2-pole battery contact and one with 3-pole battery contact. The variant with the 3-pole battery contact has longer lifetime for the battery.

It is important that the SMB unit uses the correct battery. Make sure to order the correct spare parts. Do not replace the battery contact!

Equipment	Spare part no.	Note
Serial measurement board	See <a href="#">Spare part lists on page 387</a> .	
Battery pack	See <a href="#">Spare part lists on page 387</a> .	
Gasket, base cover	3HAC 022047-001	Replace if damaged.

Continues on next page

Equipment	Spare part no.	Note
Standard toolkit	-	Content is defined in section <a href="#">Standard tools on page 383</a> .
Circuit diagram	-	See chapter <a href="#">Circuit diagram on page 389</a> .





#### CAUTION

Always cut the paint with a knife and grind the paint edge when disassembling parts. See [Cut the paint or surface on the robot before replacing parts on page 159](#).

#### Replacement, battery pack

The procedure below details how to replace the battery pack.

	Action	Note
1	 <p><b>DANGER</b></p> <p>Turn off all:</p> <ul style="list-style-type: none"> <li>• electric power supply</li> <li>• hydraulic pressure supply</li> <li>• air pressure supply</li> </ul> <p>to the robot, before entering the robot working area.</p>	
2	<p>Remove the <i>base cover</i> from the robot by unscrewing its attachment screws.</p>  <p><b>CAUTION</b></p> <p>Clean cover from metal residues before opening. Metal residues can cause shortage on the boards which can result in hazardous failures.</p>  <p><b>CAUTION</b></p> <p>Always cut the paint with a knife and grind the paint edge when disassembling parts. See <a href="#">Cut the paint or surface on the robot before replacing parts on page 159</a>.</p>	See <a href="#">Location of battery pack on page 144</a> .
3	Disconnect the battery from the serial measurement unit.	
4	<p><b>Valid for battery pack with 2-pole battery contact:</b></p> <p>Open the velcro strap and remove the battery pack.</p>	
5	<p><b>Valid for battery pack with 3-pole battery contact.</b></p> <p>Cut the cable strap and remove the battery pack.</p>	
6	Fit the new <i>battery pack</i> and connect it to the serial measurement unit (X3).	See <a href="#">Battery pack on serial measurement unit on page 145</a> .

*Continues on next page*

### 3 Maintenance

---

#### 3.4.4 Replacing the battery pack

*Continued*

	Action	Note
7	<b>Valid for battery pack with 2-pole battery contact:</b> Close the velcro strap around the battery pack.	
8	<b>Valid for battery pack with 3-pole battery contact.</b> Secure the battery with a cable strap.	
9	Check the base cover <i>gasket</i> , replace if damaged.	Spare part no. is specified in <a href="#">Required equipment on page 146</a> .
10	Refit the <i>base cover</i> to the robot.	See <a href="#">Location of battery pack on page 144</a> .
11	Update the revolution counters.	Detailed in section <a href="#">Updating revolution counters on page 345</a> .



## 3.5 Cleaning activities

### 3.5.1 Cleaning the IRB 1600/1660ID



#### WARNING

Turn off all electrical power supplies to the manipulator before entering its work space.

#### General

To secure high uptime it is important that the IRB 1600/1660ID is cleaned regularly. The frequency of cleaning depends on the environment in which the product works. Different cleaning methods are allowed depending on the type of protection of the IRB 1600/1660ID.



#### Note

Always verify the protection type of the robot before cleaning.

#### Oil spills

##### Oil spills from gearboxes

Use the following procedure if any oil spills are detected that can be suspected to originate from a gearbox.

- 1 Inspect that the oil level in the suspected gearbox is according to the recommendations, see [Inspection activities on page 132](#).
- 2 Write down the oil level.
- 3 Inspect the oil level again after, for example, 6 months.
- 4 If the oil level is decreased then replace the gearbox.

#### Special cleaning considerations

This section specifies some special considerations when cleaning the robot.

- Always use cleaning equipment as specified. Any other cleaning equipment may shorten the life of the robot.
- Always check that all protective covers are fitted to the robot before cleaning.
- Never point the water jet at connectors, joints, sealings, or gaskets.
- Do not use compressed air to clean the robot.
- Never use solvents that are not approved by ABB to clean the robot.
- Do not spray from a distance closer than 0.4 m.
- Do not remove any covers or other protective devices before cleaning the robot.

*Continues on next page*

### 3 Maintenance

#### 3.5.1 Cleaning the IRB 1600/1660ID

Continued

#### Cleaning methods

The following table defines what cleaning methods are allowed depending on the protection type.



#### Note

Rinsing with water is not allowed for a robot with integrated dressing (ID variants).

Protection type	Cleaning method			
	Vacuum cleaner	Wipe with cloth	Rinse with water	High pressure water or steam
Standard	Yes	Yes. With light cleaning detergent.	Yes. It is highly recommended that the water contains a rust-prevention solution and that the manipulator is dried afterwards.	No
Foundry Plus	Yes	Yes. With light cleaning detergent or spirit.	Yes. It is highly recommended that the water contains a rust-prevention solution.	Yes <sup>i</sup> . It is highly recommended that the water and steam contains rust preventive, without cleaning detergents.
Wash	Yes	Yes. With light cleaning detergent or spirit.	Yes. It is highly recommended that the water contains a rust-prevention solution.	Yes <sup>ii</sup> . It is highly recommended that the water and steam contains rust preventive, without cleaning detergents.
Clean room	Yes	Yes. With light cleaning detergent, spirit or isopropyl alcohol.	No	No

<sup>i</sup> Perform according to section [Cleaning with water and steam on page 150](#).

<sup>ii</sup> Perform according to section [Cleaning with water and steam on page 150](#).

#### Cleaning with water and steam

##### Instructions for rinsing with water

ABB robots with protection types *Standard*, *Foundry Plus*, *Wash*, or *Foundry Prime* can be cleaned by rinsing with water (water cleaner).<sup>1</sup>

The following list defines the prerequisites:

- Maximum water pressure at the nozzle: 700 kN/m<sup>2</sup> (7 bar)<sup>1</sup>
- Fan jet nozzle should be used, min. 45° spread
- Minimum distance from nozzle to encapsulation: 0.4 meters
- Maximum flow: 20 liters/min<sup>1</sup>

<sup>1</sup> Typical tap water pressure and flow

<sup>1</sup> See [Cleaning methods on page 150](#) for exceptions.

Continues on next page

#### Instructions for steam or high pressure water cleaning

ABB robots with protection types *Foundry Plus*, *Wash*, or *Foundry Prime* can be cleaned using a steam cleaner or high pressure water cleaner.<sup>2</sup>

The following list defines the prerequisites:

- Maximum water pressure at the nozzle: 2500 kN/m<sup>2</sup> (25 bar)
- Fan jet nozzle should be used, min. 45° spread
- Minimum distance from nozzle to encapsulation: 0.4 meters
- Maximum water temperature: 80° C

---

#### Cables

Movable cables need to be able to move freely:

- Remove waste material, such as sand, dust and chips, if it prevents cable movement.
- Clean the cables if they have a crusty surface, for example from dry release agents.

<sup>2</sup> See [Cleaning methods on page 150](#) for exceptions.

**This page is intentionally left blank**

# 4 Repair

## 4.1 Introduction

### Structure of this chapter

This chapter describes all repair activities recommended for the IRB 1600/1660ID and any external unit.

It is made up of separate procedures, each describing a specific repair activity. Each procedure contains all the information required to perform the activity, for example spare parts numbers, required special tools, and materials.



#### WARNING

Repair activities not described in this chapter must only be carried out by ABB. Otherwise damage to the mechanics and electronics may occur.

### Required equipment

The details of the equipment required to perform a specific repair activity are listed in the respective procedures.

The details of equipment are also available in different lists in the chapter [Reference information on page 375](#).

### Safety information

There are general safety information and specific safety information. The specific safety information describes the danger and safety risks while performing specific steps in a procedure. Make sure to read through the chapter [Safety on page 19](#) before commencing any service work.



#### Note

If the IRB 1600/1660ID is connected to power, always make sure that the IRB 1600/1660ID is connected to earth before starting any repair work.

For more information see:

- *Product manual - IRC5*

## 4 Repair

### 4.2.1 Performing a leak-down test

## 4.2 General procedures

### 4.2.1 Performing a leak-down test

#### When to perform a leak-down test

After refitting any motor and gearbox, the integrity of all seals enclosing the gearbox oil must be tested. This is done in a leak-down test.

#### Required equipment

Equipment, etc.	Article number	Note
Leak-down tester	-	
Leak detection spray	-	

#### Performing a leak-down test

	Action	Note
1	Finish the refitting procedure of the motor or gear in question.	
2	Remove the upper oil plug on the gear and replace it with the leak-down tester. Regulators, which are included in the leak-down test, may be required.	
3	Use caution, apply compressed air and raise the pressure with the knob until the correct value is shown on the manometer.  <b>CAUTION</b> The pressure must under no circumstance be higher than 0.25 bar (20-25 kPa). Also during the time when the pressure is raised.	Correct value: 0.2-0.25 bar (20-25 kPa)
4	Disconnect the compressed air supply.	
5	Wait for approximately 8-10 minutes and make sure that no pressure loss occurs.	If the compressed air is significantly colder or warmer than the gearbox to be tested, a slight pressure increase or decrease may occur. This is quite normal.
6	If any pressure drop occurred, then localize the leak as described in step 7. If no pressure drop occurred, then remove the leak-down tester and refit the oil plug. The test is complete.	
7	Spray any suspected leak areas with the leak detection spray. Bubbles indicate a leak.	
8	When the leak has been localized, take the necessary measures to correct the leak.	

## 4.2.2 Mounting instructions for bearings

### General

This section describes how to mount and grease different types of bearings on the robot.

### Equipment

Equipment, etc.	Article number	Note
Grease	3HAB3537-1	Used to grease the bearings, if not specified otherwise.

### Assembly of all bearings

Attend to the following instructions while mounting a bearing on the robot.

	Action	Note
1	To avoid contamination, let a new bearing remain in its wrapping until it is time for fitting.	
2	Ensure that the parts included in the bearing fitting are free from burrs, grinding waste, and other contamination. Cast components must be free of foundry sand.	
3	Bearing rings, inner rings, and roller elements must not be subjected to direct impact. The roller elements must not be exposed to any stresses during the assembly work.	

### Assembly of tapered bearings

Follow the preceding instructions for the assembly of the bearings when mounting a tapered bearing on the robot.

In addition to those instructions, the following procedure must be carried out to enable the roller elements to adjust to the correct position against the race flange.

	Action	Note
1	Tension the bearing gradually until the recommended pre-tension is achieved.  <b>Note</b> The roller elements must be rotated a specified number of turns before pre-tensioning is carried out and also rotated during the pre-tensioning sequence.	
2	Make sure the bearing is properly aligned as this will directly affect the durability of the bearing.	

### Greasing of bearings



#### Note

This instruction is not valid for solid oil bearings.

*Continues on next page*

## 4 Repair

---

### 4.2.2 Mounting instructions for bearings

*Continued*

The bearings must be greased after assembly according to the following instructions:

- The bearings must not be completely filled with grease. However, if space is available beside the bearing fitting, the bearing may be totally filled with grease when mounted, as excessive grease will be pressed out from the bearing when the robot is started.
- During operation, the bearing should be filled to 70-80% of the available volume.
- Ensure that grease is handled and stored properly to avoid contamination.

Grease the different types of bearings as following description:

- *Grooved ball bearings* must be filled with grease from both sides.
- *Tapered roller bearings* and axial needle bearings must be greased in the split condition.



## 4.2.3 Mounting instructions for seals

### General

This section describes how to mount different types of seals.

### Equipment

Equipment, etc.	Article number	Note
Grease	3HAB3537-1	Used to lubricate the seals.

### Rotating seals

The procedure below describes how to fit rotating seals.



#### CAUTION

Please observe the following before commencing any assembly of seals:

- Protect the sealing surfaces during transport and mounting.
- Keep the seal in its original wrappings or protect it well before actual mounting.
- The fitting of seals and gears must be carried out on clean workbenches.
- Use a protective sleeve for the sealing lip during mounting, when sliding over threads, keyways, etc.

	Action	Note
1	Check the seal to ensure that: <ul style="list-style-type: none"> <li>• The seal is of the correct type (provided with cutting edge).</li> <li>• There is no damage to the sealing edge (feel with a fingernail).</li> </ul>	
2	Inspect the sealing surface before mounting. If scratches or damage are found, the seal must be replaced since it may result in future leakage.	
3	Lubricate the seal with grease just before fitting. (Not too early - there is a risk of dirt and foreign particles adhering to the seal.) Fill 2/3 of the space between the dust tongue and sealing lip with grease. The rubber coated external diameter must also be greased, unless otherwise specified.	Article number is specified in <a href="#">Equipment on page 157</a> .
4	Mount the seal correctly with a mounting tool. Never hammer directly on the seal as this may result in leakage.	
5	Make sure no grease left on the robot surface.	

*Continues on next page*

## 4 Repair

### 4.2.3 Mounting instructions for seals

*Continued*

#### Flange seals and static seals

The following procedure describes how to fit flange seals and static seals.

	Action
1	Check the flange surfaces. They must be even and free from pores. It is easy to check flatness using a gauge on the fastened joint (without sealing compound). If the flange surfaces are defective, the parts may not be used because leakage could occur.
2	Clean the surfaces properly in accordance with the recommendations of ABB.
3	Distribute the sealing compound evenly over the surface, preferably with a brush.
4	Tighten the screws evenly when fastening the flange joint.

#### O-rings

The following procedure describes how to fit o-rings.

	Action	Note
1	Ensure that the correct o-ring size is used.	
2	Check the o-ring for surface defects, burrs, shape accuracy, or deformation.	Defective o-rings, including damaged or deformed o-rings, may not be used.
3	Check the o-ring grooves. The grooves must be geometrically correct and should be free of pores and contamination.	Defective o-rings may not be used.
4	Lubricate the o-ring with grease.	
5	Tighten the screws evenly while assembling.	
6	Make sure that no grease is left on the robot surface.	

## 4.2.4 Cut the paint or surface on the robot before replacing parts

## 4.2.4 Cut the paint or surface on the robot before replacing parts

## General

Follow the procedures in this section whenever breaking the paint of the robot during replacement of parts.

When replacing parts on a robot with protection type Clean Room, it is important to make sure that after the replacement, no particles will be emitted from the joint between the structure and the new part, and that the easy cleaned surface is retained.

## Required equipment

Equipment	Spare parts	Note
Sealing compound		Sikaflex 521 FC. Color white.
Tooling pin		Width 6-9 mm, made of wood.
Cleaning agent		Ethanol
Knife		
Lint free cloth		
Touch up paint Clean Room, White	3HAC036639-001	
Touch up paint Standard/Foundry Plus, ABB Orange	3HAC037052-001	

## Removing

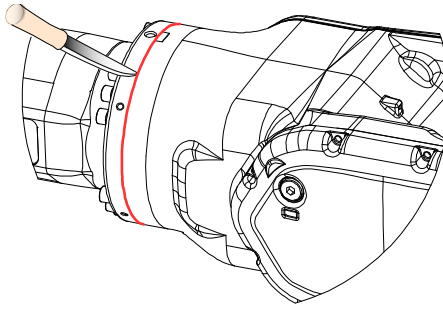
	Action	Description
1	Cut the paint with a knife in the joint between the part that will be removed and the structure, to avoid that the paint cracks.	 xx0900000121
2	Carefully grind the paint edge that is left on the structure to a smooth surface.	

## Refitting



	Action	Description
1	Before the parts are refitted, clean the joint so that it is free from oil and grease.	Use ethanol on a lint free cloth.
2	Place the tooling pin in hot water.	

*Continues on next page*

## 4 Repair

### 4.2.4 Cut the paint or surface on the robot before replacing parts

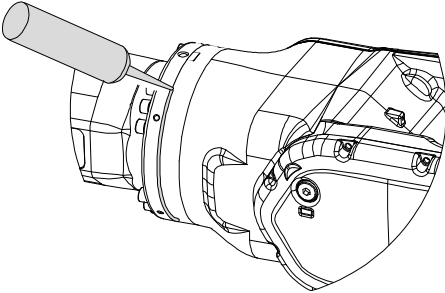
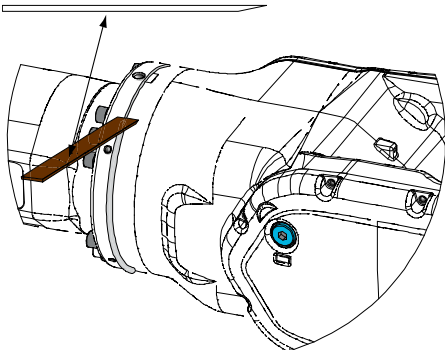
Continued

	Action	Description
3	Seal all refitted joints with Sikaflex 521FC.	 <p>xx0900000122</p>
4	Use the tooling pin to even out the surface of the Sikaflex seal.	 <p>xx0900000125</p>
5	Wait 15 minutes.	Sikaflex 521FC skin dry time (15 minutes).
6	Use Touch up paint Clean Room, white to paint the joint.   <b>Note</b>  Always read the instruction in the product data sheet in the paint repair kit for Clean Room.	3HAC036639-001

 **Note**

After all repair work, wipe the robot free from particles with spirit on a lint free cloth.

## 4.2.5 The brake release buttons may be jammed after service work

## 4.2.5 The brake release buttons may be jammed after service work

## Description

The brake release unit has push-buttons for the brake release of each axis motor. When service work is performed inside the SMB recess that includes removal and refitting of the brake release unit, the brake release buttons may be jammed after refitting.

**DANGER**

If the power is turned on while a brake release button is jammed in depressed position, the affected motor brake is released. This may cause serious personal injuries and damage to the robot.

## Elimination

To eliminate the danger after service work has been performed inside the SMB recess, follow the procedure below.

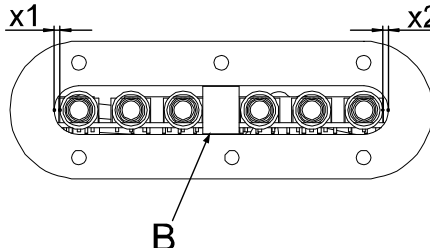
	Action	Note
1	Make sure the power is turned off.	
2	Refit the push button guard, if removed.	
3	Verify that the push-buttons of the brake release unit are working by pressing them down, one by one. Make sure none of the buttons are jammed by the push button guard.	
4	If a button gets jammed in the depressed position, the alignment of the push button unit must be adjusted so that the buttons can move freely. Remove the push button guard and: <ul style="list-style-type: none"> <li>• Make sure the centering piece (B) is properly fitted to the unit. (The piece aligns the unit vertically.)</li> <li>• Adjust the unit sideways so that the measurements x1 and x2 in the figure to the right do not differ more than 1 mm from each other.</li> </ul>	 <p>xx0600002777</p> <p>Article number for the centering piece is specified in <a href="#">Required equipment on page 252</a>.</p>
5	Refit the push button guard and check the buttons again by pressing them down, one by one.	

## 4 Repair

### 4.3.1 Replacing the cable harness, IRB 1600

## 4.3 Complete manipulator

### 4.3.1 Replacing the cable harness, IRB 1600

#### Location of cable harness

The cable harness is run through the robot from the base to the upper arm housing. The location of the harness is shown in several figures, next to the procedures, later on in this section.

Views of the cable harness may also be found in the chapter [Spare part lists on page 387](#).

#### Required equipment

Equipment	Spare part no.	Note
Cable harness IRB 1600/1.45	3HAC 021827-001	No application interface.
Cable harness IRB 1600/1.45, Customer connections	3HAC 021828-001	
Cable harness IRB 1600/1.45, Wire feeder	3HAC 021830-001	
Cable harness IRB 1600/1.2, Customer connections	3HAC 021828-003	
Gasket, upper arm cover	3HAC022049-001	Replace if damaged.
Gasket, customer connections	3HAC022050-001	Replace if damaged.
Gasket, base cover	3HAC 022047-001	Replace if damaged.
Gasket, gearbox axis 1-2	3HAC022048-001	Replace if damaged.
VK-cover	3HAA 2166-23	Upper and lower covers. 2 pcs
VK-cover	3HAA 2166-21	Middle cover.
Cable ties		
Centering piece	3HAC025815-001	Fitted to the push button unit in order to align it correctly. Replace if damaged.
Standard toolkit		Content is defined in section <a href="#">Standard tools on page 383</a> .
Circuit diagram		See chapter <a href="#">Circuit diagram on page 389</a> .



#### CAUTION

Always cut the paint with a knife and grind the paint edge when disassembling parts. See [Cut the paint or surface on the robot before replacing parts on page 159](#).

*Continues on next page*

**Illustration, covers to remove**

The figure below shows all the covers that must be removed from the robot in order to get access to the cable harness and all the brackets.

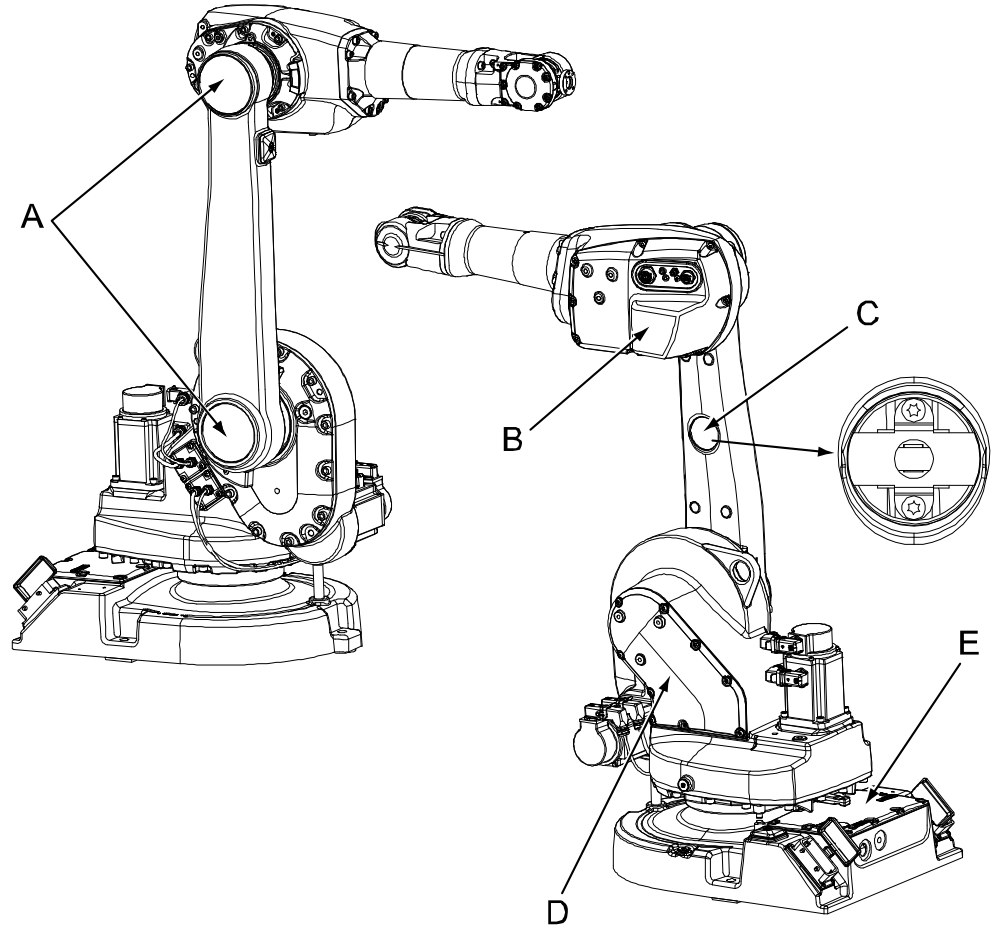

xx0400001248

A	Upper and lower VK-cover
B	Arm housing cover, with gaskets
C	VK-cover (also shown with the cover removed)
D	Cover, frame, with gasket
E	Base cover, with gasket

*Continues on next page*

## 4 Repair

### 4.3.1 Replacing the cable harness, IRB 1600

Continued

#### Deciding calibration routine

Decide which calibration routine to be used, based on the information in the table. Depending on which routine is chosen, action might be required prior to beginning the repair work of the robot, see the table.

	Action	Note
1	Decide which calibration routine to use for calibrating the robot. <ul style="list-style-type: none"> <li>Reference calibration. External cable packages (DressPack) and tools can stay fitted on the robot.</li> <li>Fine calibration. All external cable packages (DressPack) and tools must be removed from the robot.</li> </ul>	
	<b>If the robot is to be calibrated with reference calibration:</b> Find previous reference values for the axis or create new reference values. These values are to be used after the repair procedure is completed, for calibration of the robot. If no previous reference values exist, and no new reference values can be created, then reference calibration is not possible.	Follow the instructions given in the reference calibration routine on the FlexPendant to create reference values. Creating new values requires possibility to move the robot. Read more about reference calibration for Axis Calibration in <a href="#">Reference calibration routine on page 350</a> . Read more about reference calibration for Pendulum Calibration in <i>Operating manual - Calibration Pendulum</i> .
	<b>If the robot is to be calibrated with fine calibration:</b> Remove all external cable packages (DressPack) and tools from the robot.	

#### Removal, cable harness

The procedure below details how to remove the complete cable harness from the robot.

	Action	Note/Illustration
1	Decide which calibration routine to use, and take actions accordingly prior to beginning the repair procedure.	
2	 <b>DANGER</b> Turn off all: <ul style="list-style-type: none"> <li>electric power supply</li> <li>hydraulic pressure supply</li> <li>air pressure supply</li> </ul> to the robot, before entering the robot working area.	

Continues on next page

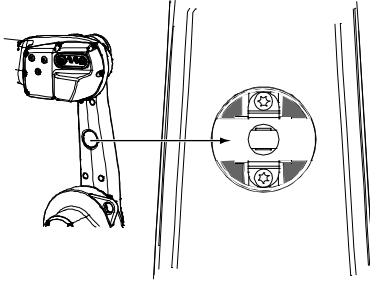

	Action	Note/Illustration
3	<p>Remove all the covers:</p> <ul style="list-style-type: none"> <li>• Remove the covers of the upper arm housing, frame and base.</li> <li>• Push out the upper and lower VK-cover from the inside.</li> <li>• Remove the middle VK-cover from the lower arm.</li> </ul> <p><b>Caution!</b> Be careful not to damage the cabling and cable bracket inside the lower arm when removing the middle VK-cover!</p> <p>The figure to the right shows the space underneath the cover. The gray areas are safe for insertion of a tool that may be inserted with a maximum depth of 20 mm!</p>	<p>All the covers are shown in the figure <i>Illustration, covers to remove on page 163</i>.</p>  <p>xx0400001247</p>
4	The cable bracket inside the lower arm is attached to the cable harness. Move the bracket to the new cabling.	
5	Disconnect all the connectors inside the upper arm housing.	Shown in the figure <i>Illustration, cabling inside upper arm housing on page 166</i> .
6	Remove all cable ties, clamps and brackets inside the upper arm housing.	Attachment points inside the upper arm housing are shown in the figure <i>Illustration, cabling inside upper arm housing on page 166</i> .
7	Disconnect all the connectors inside the frame.	Shown in the figure <i>Illustration, cabling inside frame on page 168</i> .
8	Remove the fastening plate, all cable ties and brackets from inside the frame. Remove the cable clamp unit from the fastening plate.	Attachment points inside the frame are shown in the figure <i>Illustration, cabling inside frame on page 168</i> .
9	Disconnect all the connectors at the base and remove the <i>SMB unit</i> from the base. <b>Note!</b> Do not lose the centering piece fitted to the push button unit!	Shown in the figure <i>Illustration, cabling inside base on page 169</i> .
10	Remove all cable ties and brackets at the base.	Shown in the figure <i>Illustration, cabling inside base on page 169</i> .
11	Pull out the cabling from the upper arm housing and pull it down through the lower arm.	
12	Continue pulling down the cable harness through the frame and pull it out at the rear of the base.	

Continues on next page

## 4 Repair

### 4.3.1 Replacing the cable harness, IRB 1600

Continued

#### Illustration, cabling inside upper arm housing

The figure below shows how the cabling is run inside the upper arm housing.

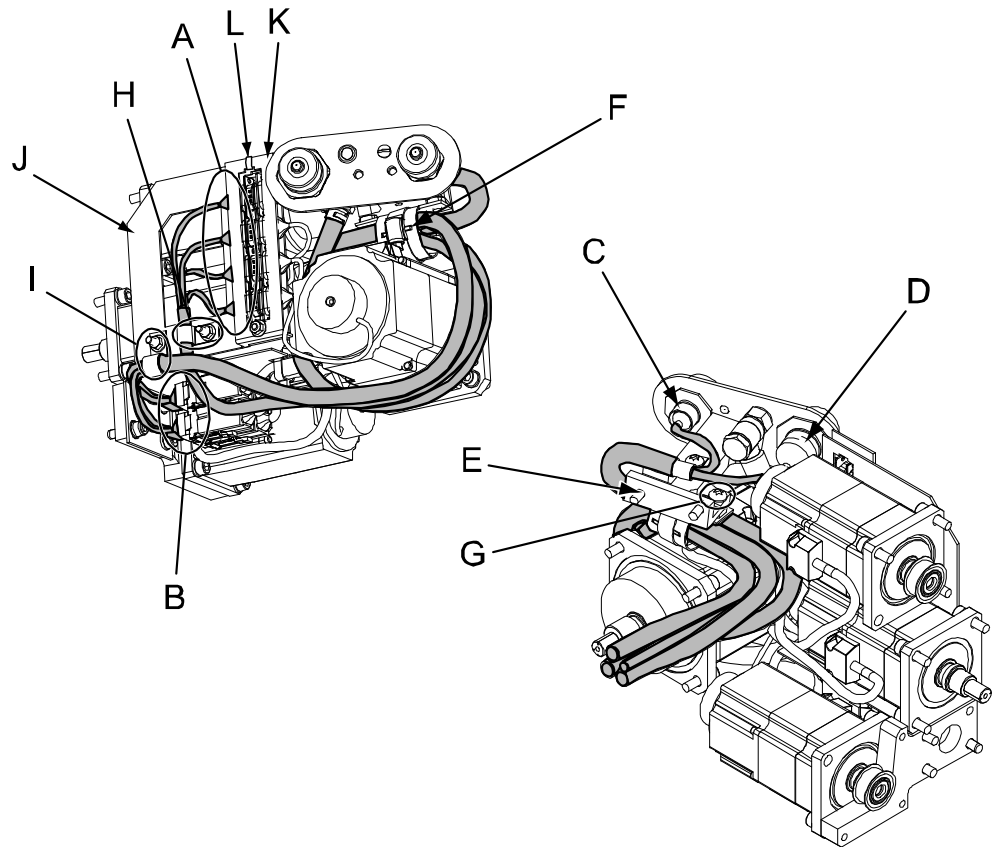

xx0400001250

A	Signal cabling; connectors for motors on axes 3, 4, 5 and 6: R3.FB3, R3.FB4, R3.FB5 and R3.FB6
B	Power cabling; connectors for motors on axes 3, 4, 5 and 6: R3.MP3, R3.MP4, R3.MP5 and R3.MP6
C	Optional connector: R2.CP
D	Optional connector: R2.CS
E	Distance console with contact panel
F	Cable clamp unit
G	Attachment screws, cable clamp unit (2 pcs, only one shown)
H	Clamp, signal cabling
I	Clamp, motor cabling
J	Connector plate
K	Connector holder
L	Cable tie, connector holder

Continues on next page

## Refitting, cable harness in upper arm housing and lower arm

The procedure below details how to refit the cabling inside the upper arm housing. The cable layout is shown in the figure *Illustration, cabling inside upper arm housing on page 166*.

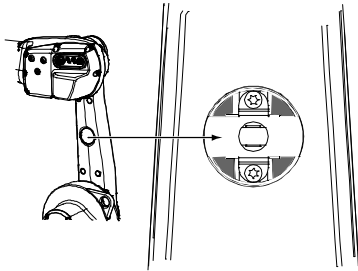
	Action	Note/Illustration
1	 <p><b>DANGER</b></p> <p>Turn off all:</p> <ul style="list-style-type: none"> <li>• electric power supply</li> <li>• hydraulic pressure supply</li> <li>• air pressure supply</li> </ul> <p>to the robot, before entering the robot working area.</p>	
2	Insert the cabling to axes 3, 4, 5 and 6 up through the lower arm and into the upper arm housing.	
3	Place the cable bracket correctly inside the lower arm and secure it by refitting the VK-cover.	<p>Spare part no. is specified in <i>Required equipment on page 162</i>.</p>  <p>xx0400001247</p> <p>Cable bracket is attached to the cabling with 2 screws, M6x8.</p>
4	Fasten the cabling inside the upper arm housing by fitting the <i>cable clamp unit</i> to the <i>distance console</i> with two <i>attachment screws</i> .	Shown in the figure <i>Illustration, cabling inside upper arm housing on page 166</i> .
5	Fit the motor and signal cabling to the <i>connector plate</i> with <i>clamps</i> .	Hexagon nut: M5. 1 pc for each clamp.
6	Reconnect the signal cable connectors and slide them into the <i>connector holder</i> . Notice that one of the cable ties in the connector holder plate must be removed in order to insert the cables into the holder. Refit it when the connectors are inserted.	Shown in the figure <i>Illustration, cabling inside upper arm housing on page 166</i> .
7	Reconnect the motor cable connectors.	
8	Reconnect optional connectors, if any, at the contact panel.	
9	Place the cabling correctly inside the housing and secure it with cable ties.	The cable layout is shown in the figure <i>Illustration, cabling inside upper arm housing on page 166</i> .

Continues on next page

## 4 Repair

### 4.3.1 Replacing the cable harness, IRB 1600

Continued

	Action	Note/Illustration
10	Refit the <i>arm housing cover</i> with eight attachment screws. Check the two <i>gaskets</i> and replace, if damaged.	8 pcs, M6. Shown in the figure <i>Illustration, covers to remove on page 163</i> . Spare part no. is specified in <i>Required equipment on page 162</i> .
11	Fit new <i>VK-covers</i> to the lower arm.	Spare part no. is specified in <i>Required equipment on page 162</i> .
12	Continue refitting the cable harness according to procedure <i>Refitting, cable harness in frame and base on page 170</i> .	

#### Illustration, cabling inside frame

The figure below shows how the cabling is run inside the frame.

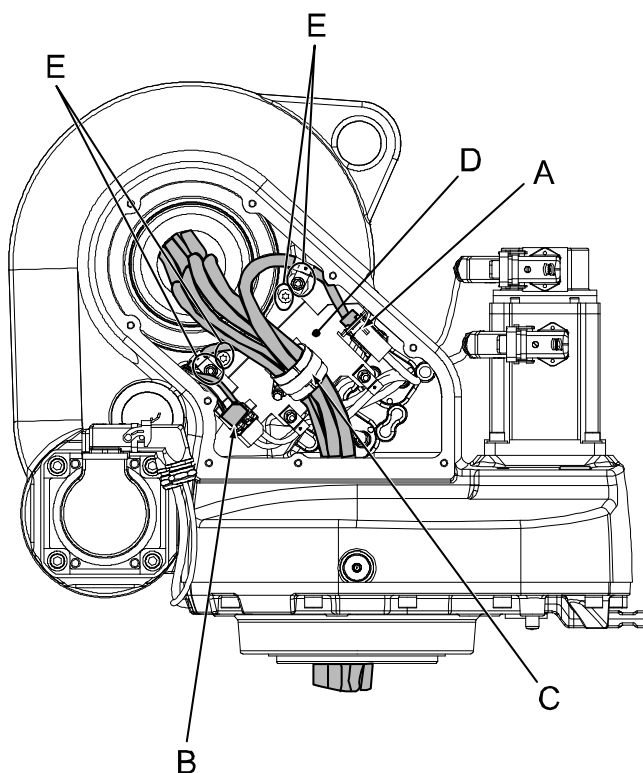

xx0400001249

A	Power cabling; connectors for motors on axes 1 and 2: R3.MP1 and R3.MP2
B	Signal cabling; connectors for motors on axes 1 and 2: R3.FB1 and R3.FB2
C	Cable clamp unit (attachment screws behind the fastening plate)
D	Fastening plate
E	Attachment screws and nuts

Continues on next page

**Illustration, cabling inside base**

The figure below shows how the cabling is run inside the base. Optional cabling is also shown in the figure, but not further specified.

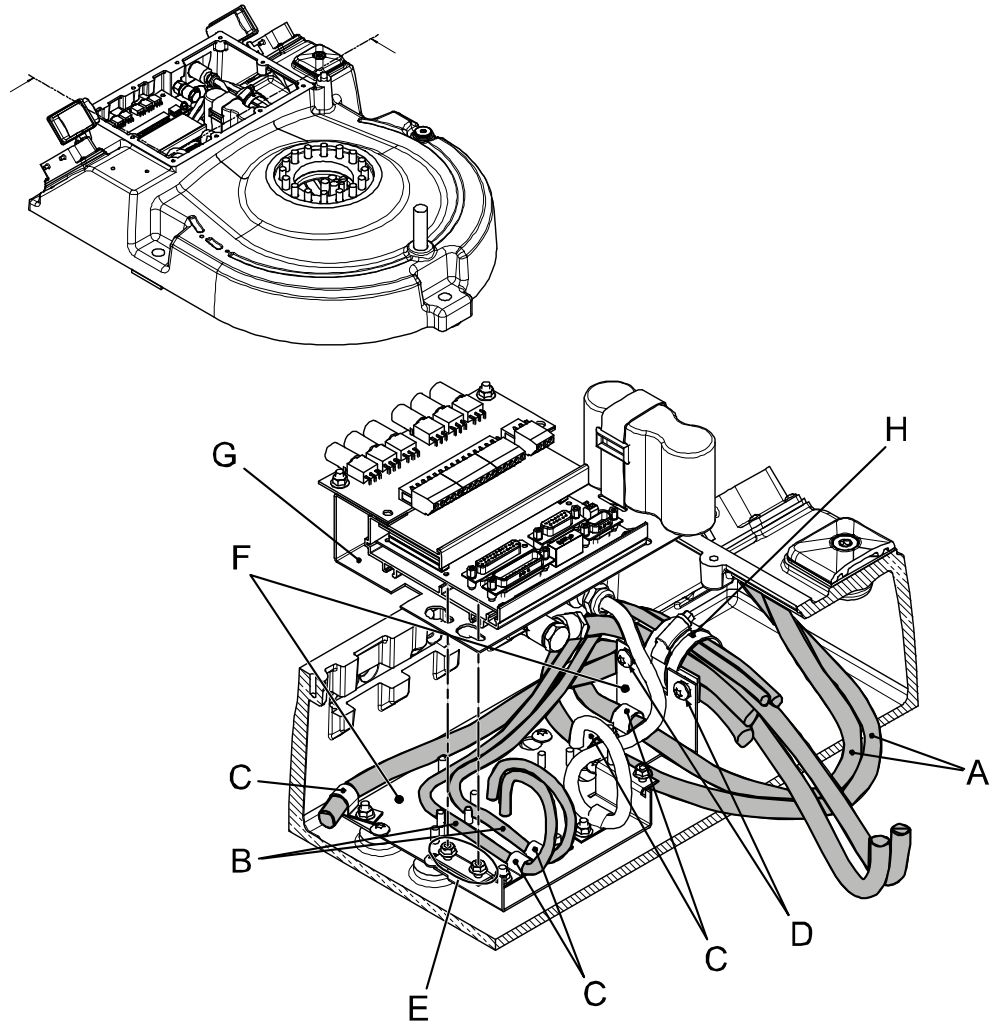

xx0500001388

A	Power cabling
B	Signal cabling
C	Clamp with hexagon nut
D	Attachment screws, cable clamp unit
E	Hexagon nut, SMB plate
F	Fastening plate
G	SMB unit
H	Cable clamp unit

Continues on next page



## 4 Repair

### 4.3.1 Replacing the cable harness, IRB 1600

Continued

#### Refitting, cable harness in frame and base

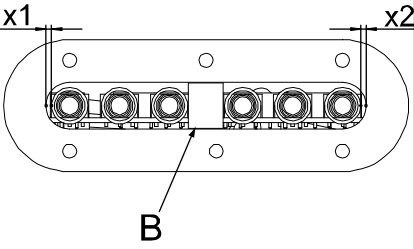
The procedure below details how to refit the cabling inside the frame and the base. The cable layout is shown in the figures [Illustration, cabling inside frame on page 168](#) and [Illustration, cabling inside base on page 169](#).

	Action	Note
1	 <p><b>DANGER</b></p> <p>Turn off all:</p> <ul style="list-style-type: none"> <li>• electric power supply</li> <li>• hydraulic pressure supply</li> <li>• air pressure supply</li> </ul> <p>to the robot, before entering the robot working area.</p>	
2	Run the cables from the lower arm into the frame.	
3	Fit the <i>cable clamp unit</i> to the <i>fastening plate</i> with two attachment screws, but do not secure the plate to the frame yet.	Shown in the figure <a href="#">Illustration, cabling inside frame on page 168</a> .
4	Run the cabling down to the base. Pull it out at the rear of the base.	
5	Connect all the connectors inside the frame and secure all plates and cable brackets inside the frame with <i>attachment screws and nuts</i> .	Shown in the figure <a href="#">Illustration, cabling inside frame on page 168</a> .
6	In the base, secure the cabling to the bottom <i>fastening plate</i> : <ul style="list-style-type: none"> <li>• fit the <i>cable clamp unit</i> with two <i>attachment screws (M6)</i>.</li> <li>• fit the separate cables with <i>clamps and hexagon nuts</i>.</li> </ul>	Shown in the figure <a href="#">Illustration, cabling inside base on page 169</a> .
7	Refit the <i>SMB unit</i> to the fastening plate with hexagon nuts.	Shown in the figure <a href="#">Illustration, cabling inside base on page 169</a> .
8	Refit the centering piece (B) to the push button unit in order to align it vertically. Also make sure that the unit is correctly aligned sideways: the measurements x1 and x2 in the figure to the right should not differ more than 1 mm from each other!	 <p>xx0600002777</p> <p>Art. no. for the centering piece is specified in <a href="#">Required equipment on page 162</a>.</p>
9	Refit the push button guard to the robot base.	
10	 <p><b>WARNING</b></p> <p>Before continuing any service work, please observe the safety information in section <a href="#">The brake release buttons may be jammed after service work on page 161!</a></p>	

Continues on next page

	Action	Note
11	Connect the: <ul style="list-style-type: none"> <li>• signal cable connectors to the SMB unit</li> <li>• power cable connector to the housing in the base</li> <li>• optional cabling, if any</li> <li>• ground cable.</li> </ul>	Shown in the figure <i>Illustration, cabling inside base on page 169</i> .
12	Refit the <i>covers</i> to the frame and to the base. Replace the <i>gaskets</i> , if damaged.	Shown in the figure <i>Illustration, covers to remove on page 163</i> . Spare part no. is specified in <i>Required equipment on page 162</i> .
13	Recalibrate the robot!	Pendulum Calibration is described in <i>Operating manual - Calibration Pendulum</i> , enclosed with the calibration tools. Axis Calibration is described in <i>Calibrating with Axis Calibration method on page 349</i> . General calibration information is included in section <i>Calibration on page 337</i> .

## 4 Repair

### 4.3.2 Replacing the cable harness, 1600ID/1660ID

### 4.3.2 Replacing the cable harness, 1600ID/1660ID

#### Location of the harness

The location of the harness is shown in several figures, next to the procedures, later on in this section.

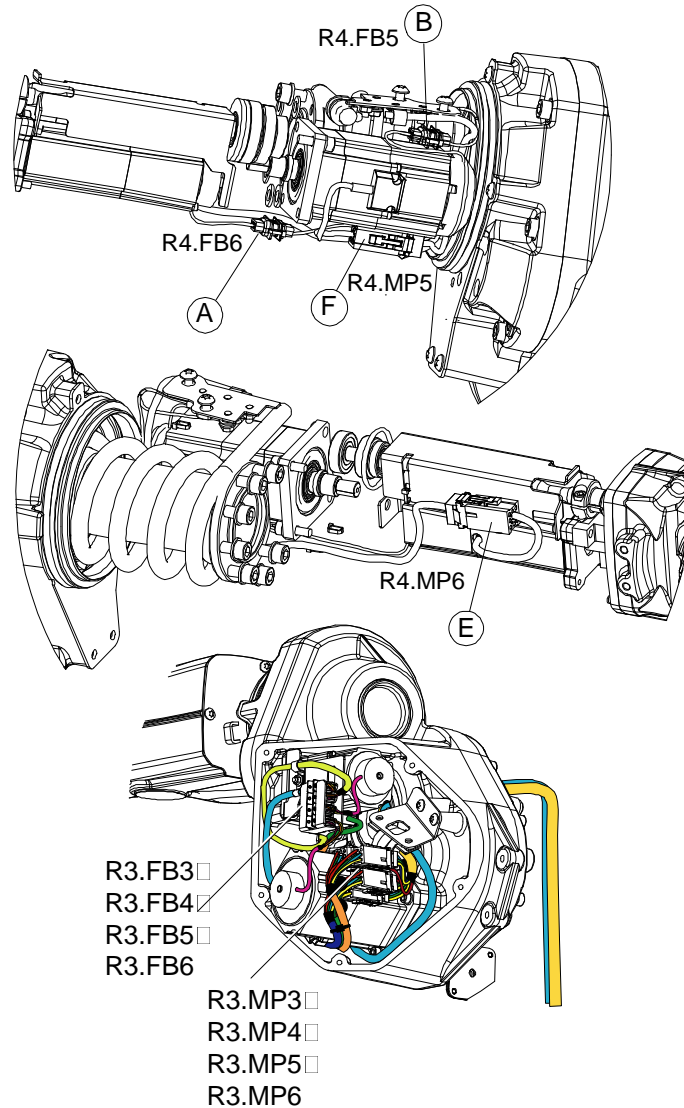

xx070000038

A	R4.FB6
B	R4.FB5
E	R4.MP6
F	R4.MP5

#### Required equipment

Equipment	Spare part no.	Note
Standard toolkit		<a href="#">Standard tools on page 383</a>

*Continues on next page*



Equipment	Spare part no.	Note
Circuit diagram		
Cable ties		
VK- cover	3HAA 2166-23	Upper and lower covers. 2 pcs
Cable harness axis 5-6	3HAC027523-002	IRB 1600ID-4/1.5
	3HAC055651-001	IRB 1660ID-X/1.55

**CAUTION**

Be careful when handling the wrist. Always hold on the casting, do not hold on the wrist cover. This can damage the sealing which will cause oil leakage.

**CAUTION**

Always cut the paint with a knife and grind the paint edge when disassembling parts. See [Cut the paint or surface on the robot before replacing parts on page 159](#).

**Deciding calibration routine**

Decide which calibration routine to be used, based on the information in the table. Depending on which routine is chosen, action might be required prior to beginning the repair work of the robot, see the table.

	Action	Note
1	Decide which calibration routine to use for calibrating the robot. <ul style="list-style-type: none"> <li>Reference calibration. External cable packages (DressPack) and tools can stay fitted on the robot.</li> <li>Fine calibration. All external cable packages (DressPack) and tools must be removed from the robot.</li> </ul>	
	<b>If the robot is to be calibrated with reference calibration:</b> Find previous reference values for the axis or create new reference values. These values are to be used after the repair procedure is completed, for calibration of the robot. If no previous reference values exist, and no new reference values can be created, then reference calibration is not possible.	Follow the instructions given in the reference calibration routine on the FlexPendant to create reference values. Creating new values requires possibility to move the robot. Read more about reference calibration for Axis Calibration in <a href="#">Reference calibration routine on page 350</a> . Read more about reference calibration for Pendulum Calibration in <a href="#">Operating manual - Calibration Pendulum</a> .
	<b>If the robot is to be calibrated with fine calibration:</b> Remove all external cable packages (DressPack) and tools from the robot.	

Continues on next page

## 4 Repair

### 4.3.2 Replacing the cable harness, 1600ID/1660ID

Continued

#### Removal, cable harness lower arm and upper arm back

The procedure below describes removal of the complete cable harness in upper arm back.

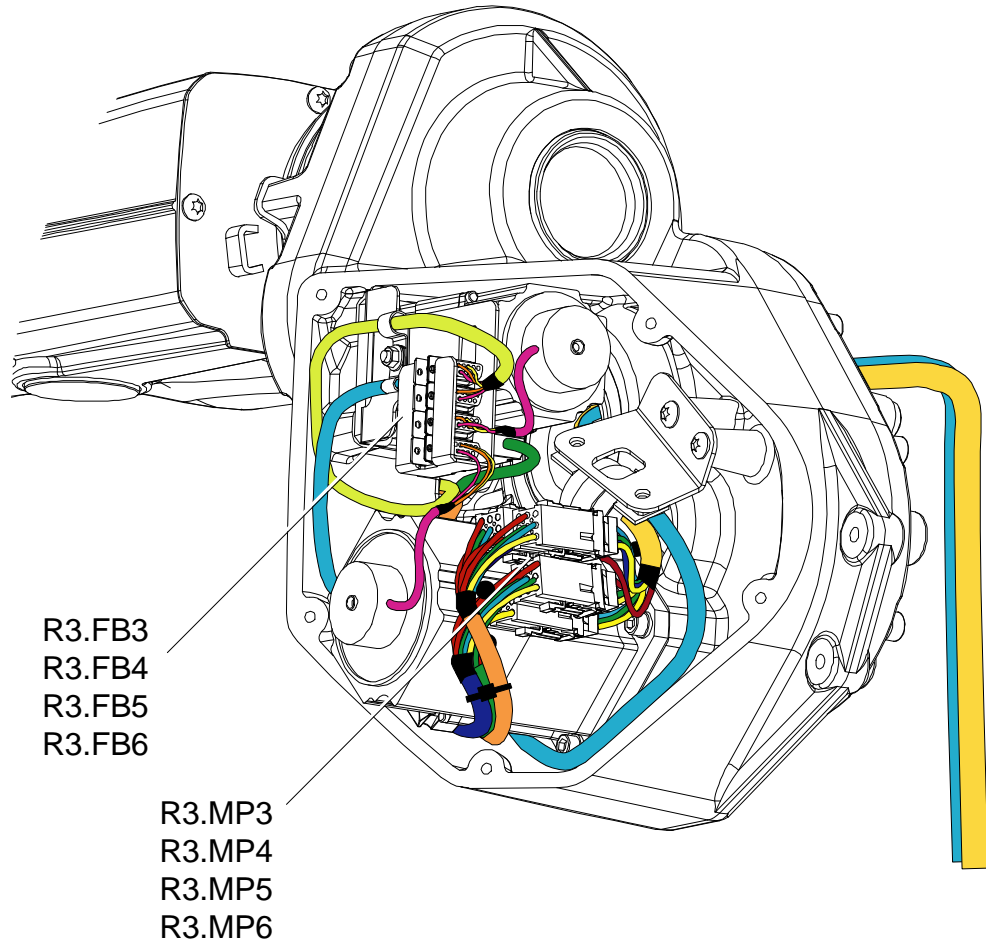

xx070000105

	Action	Note
1	Decide which calibration routine to use, and take actions accordingly prior to beginning the repair procedure.	
2	 <b>DANGER</b> Turn off all: <ul style="list-style-type: none"><li>• electric power supply</li><li>• hydraulic pressure supply</li><li>• air pressure supply</li></ul> to the robot, before entering the robot working area.	
3	Remove the cover to the upper arm.	

Continues on next page

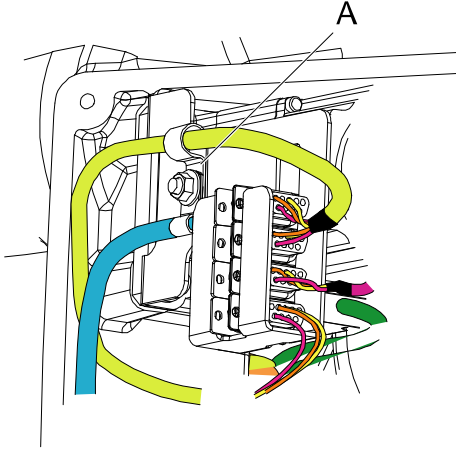
Action	Note
<p>4 Remove the hexagon nut with flange (A) holding the two (2) clamps.</p>	 <p>xx0700000106</p> <p>A Hexagon nut with flange</p>
<p>5 Disconnect R3.FB3 - R3.FB6.</p>	
<p>6 Disconnect R3.MP3 - R3.MP6.</p>	
<p>7 Remove the cable harness from the lower arm.</p>	<p>Follow instructions in section <a href="#">Replacing the cable harness, IRB 1600 on page 162</a>.</p>

**Removal, cable harness upper arm tube**

The procedure below describes removal of the complete cable harness in upper arm tube.

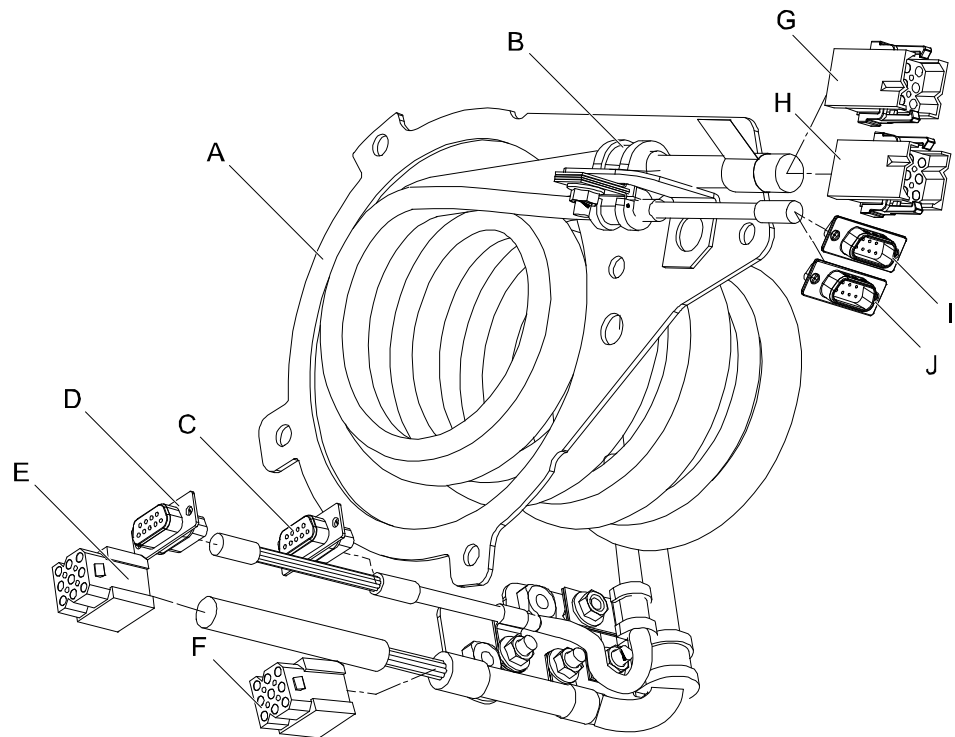

xx0700000099

A	Cover plate
---	-------------

Continues on next page

## 4 Repair

### 4.3.2 Replacing the cable harness, 1600ID/1660ID

Continued

B	Clamp
C	R4.FB5
D	R4.FB6
E	R4.MP6
F	R4.MP5
G	R3.MP5
H	R3.MP6
I	R3.FB5
J	R3.FB6

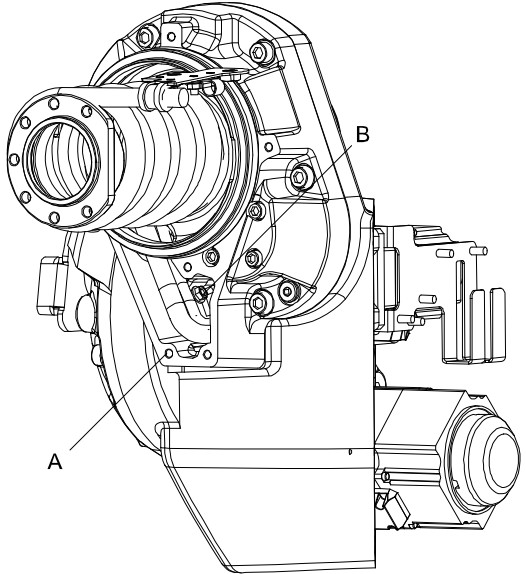
	Action	Note
1	 <p><b>DANGER</b></p> <p>Turn off all:</p> <ul style="list-style-type: none"> <li>• electric power supply</li> <li>• hydraulic pressure supply</li> <li>• air pressure supply</li> </ul> <p>to the robot, before entering the robot working area.</p>	
2	Remove the upper arm tube.	<p>Described in section:</p> <ul style="list-style-type: none"> <li>• IRB 1600ID: <a href="#">Replacement of motor, axis 5, IRB 1600ID on page 294</a></li> <li>• IRB 1660ID: <a href="#">Replacement of motor, axis 5, IRB 1660ID on page 302</a></li> </ul>
3	Remove all the Torx pan head screw (A) holding the cover.	 <p>xx0700000113</p> <p>A Torx pan head screw M6x12 B Hexagon nut with flange M5</p>

Continues on next page

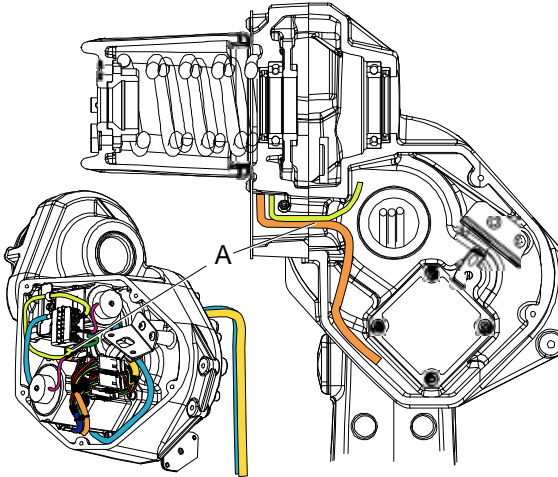
	Action	Note
4	Remove the cover plate.	 <b>Tip</b> The spare part cable harness 3HAC027523-002 includes a galvanized coverplate without paint. If a painted cover is preferred, use the old cover plate.
5	Remove the cable pulling it out through the passage (A).	 xx0700000114

### Refitting, cable harness

The procedure below describes refitting of the complete cable harness.

	Action	Note
1	Refit the cable harness.	Described in section <a href="#">Refitting, cable harness in upper arm housing and lower arm on page 167</a>
2	Refit the upper arm tube.	Described in section <a href="#">Refitting, motor axis 5 on page 299</a> .
3	Refit the connections in the upper arm.	Shown in figure <a href="#">Location of the harness on page 172</a> .
4	Recalibrate the robot.	Pendulum Calibration is described in <i>Operating manual - Calibration Pendulum</i> , enclosed with the calibration tools. Axis Calibration is described in <a href="#">Calibrating with Axis Calibration method on page 349</a> . General calibration information is included in section <a href="#">Calibration on page 337</a> .

## 4 Repair

### 4.3.3 Replacement of complete arm system

### 4.3.3 Replacement of complete arm system

#### Location of complete arm system

The complete arm system includes complete upper and lower arms.

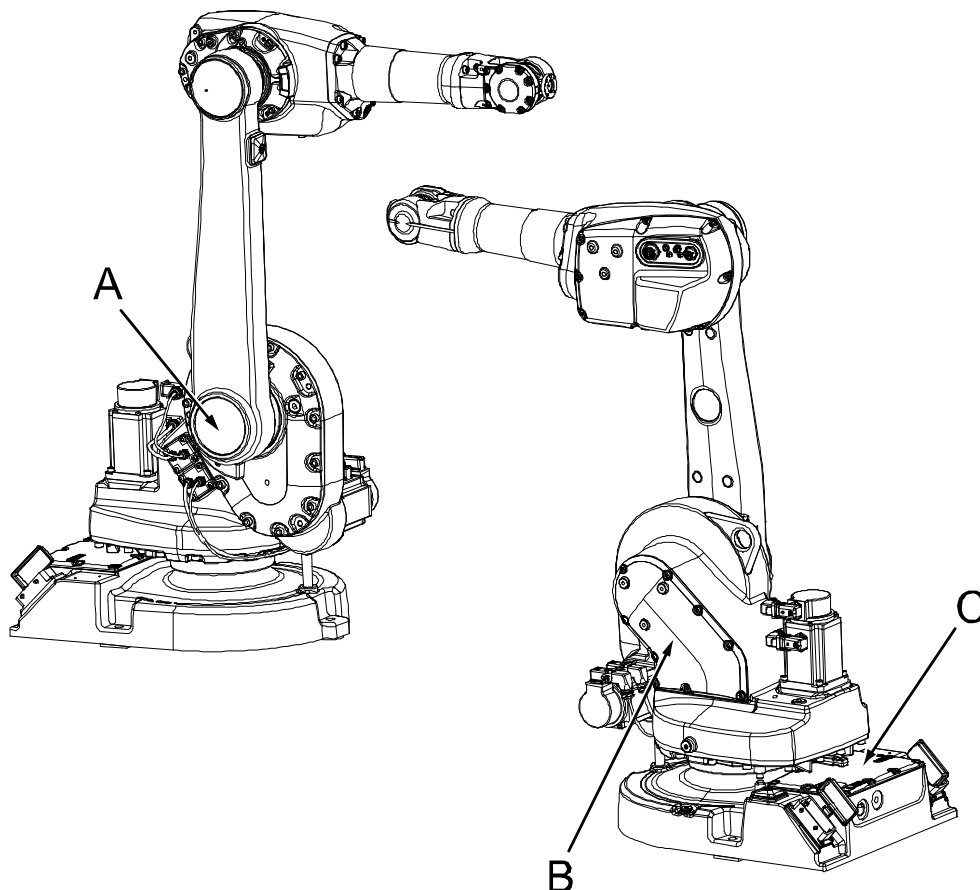

xx0500001443

A	VK-cover (attachment screws underneath cover)
B	Cover, frame
C	Cover, base

#### Required equipment

Equipment	Art. no.	Note
Lifting slings	-	
VK-cover	3HAA 2166-23	
Sealing ring (V-ring)	3HAB3732-13	Replace if damaged.
Isopropanol	-	Used to clean the mating surfaces.
Locking liquid	-	Loctite 574
Standard toolkit	-	Content is defined in section <a href="#">Standard tools on page 383</a> .

*Continues on next page*

Equipment	Art. no.	Note
Other tools and procedures may be required. See references to these procedures in the step-by-step instructions below.		These procedures include references to the tools required.

**CAUTION**

Always cut the paint with a knife and grind the paint edge when disassembling parts. See [Cut the paint or surface on the robot before replacing parts on page 159](#).

**Deciding calibration routine**

Decide which calibration routine to be used, based on the information in the table. Depending on which routine is chosen, action might be required prior to beginning the repair work of the robot, see the table.

	Action	Note
1	Decide which calibration routine to use for calibrating the robot. <ul style="list-style-type: none"> <li>Reference calibration. External cable packages (DressPack) and tools can stay fitted on the robot.</li> <li>Fine calibration. All external cable packages (DressPack) and tools must be removed from the robot.</li> </ul>	
	<p><b>If the robot is to be calibrated with reference calibration:</b></p> <p>Find previous reference values for the axis or create new reference values. These values are to be used after the repair procedure is completed, for calibration of the robot.</p> <p>If no previous reference values exist, and no new reference values can be created, then reference calibration is not possible.</p>	<p>Follow the instructions given in the reference calibration routine on the FlexPendant to create reference values.</p> <p>Creating new values requires possibility to move the robot.</p> <p>Read more about reference calibration for Axis Calibration in <a href="#">Reference calibration routine on page 350</a>.</p> <p>Read more about reference calibration for Pendulum Calibration in <i>Operating manual - Calibration Pendulum</i>.</p>
	<p><b>If the robot is to be calibrated with fine calibration:</b></p> <p>Remove all external cable packages (DressPack) and tools from the robot.</p>	

**Removing the complete arm system**

Use this procedure to remove the complete arm system from the robot.



	Action	Note
1	Decide which calibration routine to use, and take actions accordingly prior to beginning the repair procedure.	
2	Move the robot to its calibration position.	

*Continues on next page*

## 4 Repair

### 4.3.3 Replacement of complete arm system

Continued



	Action	Note
3	 <b>DANGER</b> Turn off all: <ul style="list-style-type: none"><li>• electric power supply</li><li>• hydraulic pressure supply</li><li>• air pressure supply</li></ul> to the robot, before entering the robot working area.	
4	Remove the covers from the base and the frame.	
5	Release the cable harness from below upwards to the lower arm by: <ul style="list-style-type: none"><li>• disconnecting all the connectors inside the base and the frame.</li><li>• removing all cable ties and brackets inside the base and the frame.</li></ul>	The cable layouts inside the base and the frame are shown in the figures: <ul style="list-style-type: none"><li>• <a href="#">Illustration, cabling inside base on page 169.</a></li><li>• <a href="#">Illustration, cabling inside frame on page 168.</a></li></ul>
6	Push out the VK-cover from inside of the frame.	Shown in the figure <a href="#">Location of complete arm system on page 178.</a>
7	 <b>CAUTION</b> The complete arm system weighs 55 kg. All lifting accessories used must be sized accordingly!	
8	Fit lifting slings to the upper arm to unload the weight of the complete arm system.	
9	Unscrew the 12 attachment screws and remove the one washer. Be careful when pulling the cabling through base, frame and lower arm. Use tape to bunch the connectors and protect them.	
10	Gently pull out the cabling from the frame and base while lifting away the complete arm system.	
11	Secure the cable harness to the arm system in a way that it is not damaged in the continued process.	
12	Check the <i>sealing ring</i> . Replace if damaged.	

Continues on next page

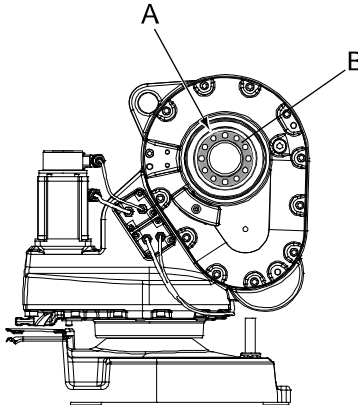

## Refitting, complete arm system

The procedure below details how to refit the complete arm system to the robot.

	Action	Note/Illustration
1	 <b>DANGER</b> Turn off all: <ul style="list-style-type: none"> <li>• electric power supply</li> <li>• hydraulic pressure supply</li> <li>• air pressure supply</li> </ul> to the robot, before entering the robot working area.	
2	Clean the mating surfaces on both the lower arm and on the frame with isopropanol. Also clean the area where the sealing ring is fitted, if it has been removed.	
3	Fit the <i>sealing ring</i> properly to the frame. Replace it if damaged.	Art. no. is specified in <a href="#">Required equipment on page 178</a> .  xx0400001245 <ul style="list-style-type: none"> <li>• A: Sealing ring</li> <li>• B: Mating surface</li> </ul>
4	Lubricate the attachment holes at the mating surface on the frame with Loctite 574.	
5	 <b>CAUTION</b> The complete arm system weighs 55 kg. All lifting accessories used must be sized accordingly!	
6	Fit the lifting slings to the complete arm system and lift it into position while inserting the cabling into the frame.	
7	Fit the lower arm against the frame, fit the one washer and secure with the 12 attachment screws.	12 pcs; M10 x 40, tightening torque: 70 Nm.
8	Refit the cabling inside the frame and the base.	Detailed in section <a href="#">Refitting, cable harness in frame and base on page 170</a> .
9	Fit a new <i>VK-cover</i> to the lower arm.	Art. no. is specified in <a href="#">Required equipment on page 178</a> .

Continues on next page

## 4 Repair

### 4.3.3 Replacement of complete arm system

*Continued*

	Action	Note/Illustration
10	Recalibrate the robot!	<p>Pendulum Calibration is described in <i>Operating manual - Calibration Pendulum</i>, enclosed with the calibration tools.</p> <p>Axis Calibration is described in <a href="#">Calibrating with Axis Calibration method on page 349</a>.</p> <p>General calibration information is included in section <a href="#">Calibration on page 337</a>.</p>
11	 <b>DANGER</b> Make sure all safety requirements are met when performing the first test run. These are further detailed in the section <a href="#">First test run may cause injury or damage on page 28</a> .	

## 4.4 Upper and lower arm

### 4.4.1 Replacing the complete upper arm, IRB 1600

#### General

The complete upper arm is considered a spare part, including wrist, gearboxes and motors.

#### Location of upper arm

The figure below shows the location of the upper arm on the robot and some of the upper arm components.

A more detailed view of the upper arm may be found in the spare part view, see *Spare parts - Upper arm, exploded view*.

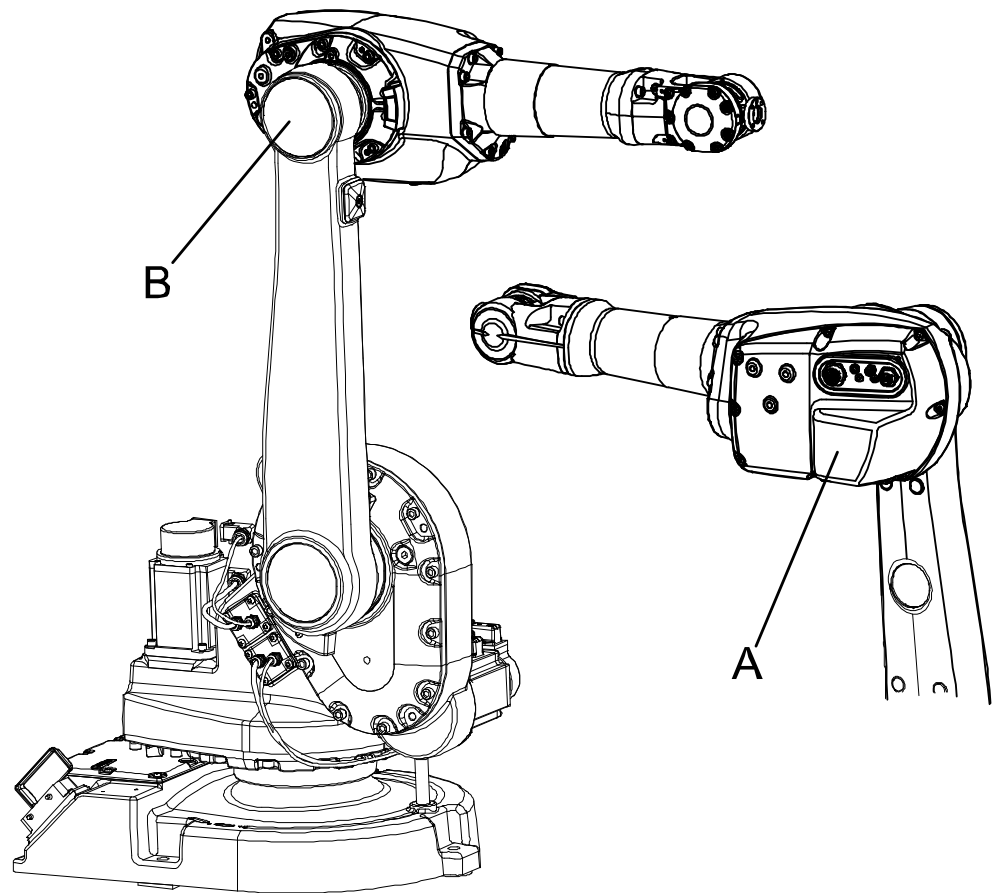

xx0400001218

A	Arm housing cover, including gaskets for the cover and the contact panel
B	VK cover. Upper arm attachment screws inside

*Continues on next page*

## 4 Repair

### 4.4.1 Replacing the complete upper arm, IRB 1600

*Continued*

#### Required equipment

Equipment	Spare part no.	Art. no.	Note
Upper arm	For spare part number, see: <ul style="list-style-type: none"> <li><a href="#">Spare part lists on page 387.</a></li> </ul>		Includes the wrist unit. All gearboxes are filled with oil at delivery. <b>Note!</b> This upper arm spare is interchangeable with upper arm spare with art. no. 3HAC 023630-001. But this change of upper arm requires software 5.07.01.
VK-cover	3HAA 2166-23		
Sealing ring (V-ring)	3HAB3732-19		Replace if damaged.
Gasket, upper arm cover	3HAC022049-001		Replace if damaged.
Gasket, customer connections	3HAC022050-001		Replace if damaged.
Grease		3HAB 3537-1	To lubricate the sealing ring (V-ring).
Locking liquid		-	Loctite 574
Lifting slings		-	
Standard toolkit			Content is defined in section <a href="#">Standard tools on page 383.</a>
Other tools and procedures may be required. See references to these procedures in the step-by-step instructions below.			These procedures include references to the tools required.



#### CAUTION

Always cut the paint with a knife and grind the paint edge when disassembling parts. See [Cut the paint or surface on the robot before replacing parts on page 159.](#)

#### Deciding calibration routine

Decide which calibration routine to be used, based on the information in the table. Depending on which routine is chosen, action might be required prior to beginning the repair work of the robot, see the table.



	Action	Note
1	Decide which calibration routine to use for calibrating the robot. <ul style="list-style-type: none"> <li>Reference calibration. External cable packages (DressPack) and tools can stay fitted on the robot.</li> <li>Fine calibration. All external cable packages (DressPack) and tools must be removed from the robot.</li> </ul>	

*Continues on next page*

Action	Note
<p><b>If the robot is to be calibrated with reference calibration:</b> Find previous reference values for the axis or create new reference values. These values are to be used after the repair procedure is completed, for calibration of the robot.</p> <p>If no previous reference values exist, and no new reference values can be created, then reference calibration is not possible.</p>	<p>Follow the instructions given in the reference calibration routine on the FlexPendant to create reference values.</p> <p>Creating new values requires possibility to move the robot.</p> <p>Read more about reference calibration for Axis Calibration in <a href="#">Reference calibration routine on page 350</a>.</p> <p>Read more about reference calibration for Pendulum Calibration in <i>Operating manual - Calibration Pendulum</i>.</p>
<p><b>If the robot is to be calibrated with fine calibration:</b> Remove all external cable packages (DressPack) and tools from the robot.</p>	

### Removal, complete upper arm

The procedure below details how to remove the complete upper arm from the robot.

	Action	Note/Illustration
1	Decide which calibration routine to use, and take actions accordingly prior to beginning the repair procedure.	
2	Move the upper arm to a horizontal position.	
3	 <p><b>DANGER</b></p> <p>Turn off all:</p> <ul style="list-style-type: none"> <li>• electric power supply</li> <li>• hydraulic pressure supply</li> <li>• air pressure supply</li> </ul> <p>to the robot, before entering the robot working area.</p>	
4	Remove the <i>arm housing cover</i> from the upper arm.	Shown in the figure <a href="#">Location of upper arm on page 183</a> .
5	Disconnect all connectors inside the arm housing and loosen the cabling from straps and brackets.	The cabling and all connectors inside the upper arm housing are shown in the figure <a href="#">Illustration, cabling inside upper arm housing on page 166</a> .
6	Remove the <i>VK-cover</i> from the lower arm by pushing it out from the inside. Pull out the cabling from the arm housing.	Shown in the figure <a href="#">Location of upper arm on page 183</a> .
7	Secure the weight of the arm with lifting slings.	
8	 <p><b>CAUTION</b></p> <p>The complete upper arm weighs 55 kg without any additional equipment fitted! All lifting accessories used must be sized accordingly!</p>	

Continues on next page

## 4 Repair

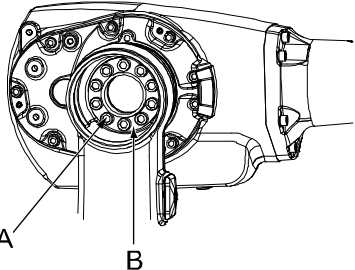

### 4.4.1 Replacing the complete upper arm, IRB 1600

Continued



	Action	Note/Illustration
9	Remove the 10 attachment screws (A) and the single washer (B).	 <p>xx0400001219</p>
10	Remove the upper arm, lift it away and place it securely.	

### Refitting, complete upper arm

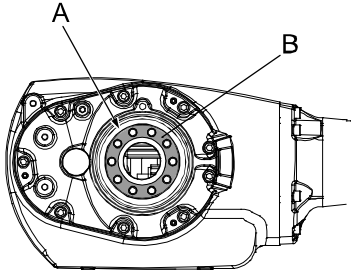
The procedure below details how to refit the complete upper arm to the robot.

	Action	Note/Illustration
1	 <p><b>DANGER</b></p> <p>Turn off all:</p> <ul style="list-style-type: none"> <li>• electric power supply</li> <li>• hydraulic pressure supply</li> <li>• air pressure supply</li> </ul> <p>to the robot, before entering the robot working area.</p>	
2	Wipe the contact surfaces clean on both the upper and lower arm.	
3	 <p><b>CAUTION</b></p> <p>The complete upper arm weighs 55 kg without any additional equipment fitted! All lifting accessories used must be sized accordingly!</p>	
4	Attach lifting slings to the upper arm and lift it.	
5	Lubricate the <i>sealing ring</i> (A) with <i>grease</i> and fit it to the upper arm. Replace the sealing ring, if damaged.	 <p>xx0400001220</p> <ul style="list-style-type: none"> <li>• A: Sealing ring, spare part no. is specified in <a href="#">Required equipment on page 184</a>.</li> <li>• B: Contact surface.</li> </ul>

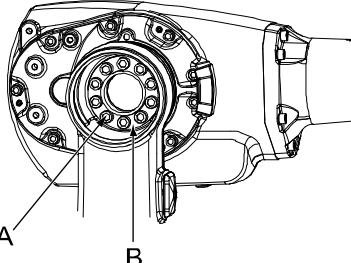
Continues on next page

	Action	Note/Illustration
6	Lubricate the the contact surface, upper arm, with Loctite 574.	
7	Lift the upper arm to mounting position, fit the washer (B) and secure the upper arm with the 10 attachment screws (A).	<p>10 pcs: M10 x 40. Tightening torque: 70 Nm.</p>  <p>xx0400001219</p>
8	Run the cabling through the lower arm and into the arm housing.	
9	Connect all the connectors in the arm housing and secure the cabling with brackets and straps.	Refitting of the cabling in the upper arm housing is further detailed in section <a href="#">Refitting, cable harness in upper arm housing and lower arm on page 167</a> .
10	Refit the <i>arm housing cover</i> to the upper arm. Check the two <i>gaskets</i> in the cover and replace them, if damaged.	Shown in the figure <a href="#">Location of upper arm on page 183</a> . Spare part no. is specified in section <a href="#">Required equipment on page 184</a> .
11	Refit a new <i>VK-cover</i> to the lower arm.	Shown in the figure <a href="#">Location of upper arm on page 183</a> . Spare part no. is specified in section <a href="#">Required equipment on page 184</a> .
12	Recalibrate the robot!	<p>Pendulum Calibration is described in <i>Operating manual - Calibration Pendulum</i>, enclosed with the calibration tools.</p> <p>Axis Calibration is described in <a href="#">Calibrating with Axis Calibration method on page 349</a>.</p> <p>General calibration information is included in section <a href="#">Calibration on page 337</a>.</p>
13	 <p><b>DANGER</b></p> <p>Make sure all safety requirements are met when performing the first test run. These are further detailed in the section <a href="#">First test run may cause injury or damage on page 28</a>.</p>	

## 4 Repair

### 4.4.2 Replacing the complete upper arm, IRB 1600ID/1660ID

### 4.4.2 Replacing the complete upper arm, IRB 1600ID/1660ID



#### Note

Recalibration of robot axis 3-6 is required after replacement of upper arm.

#### Location of the complete upper arm

The complete upper arm is considered a spare part, including wrist, gearboxes and motors. The figure below shows the location of the upper arm and connection to the lower arm.

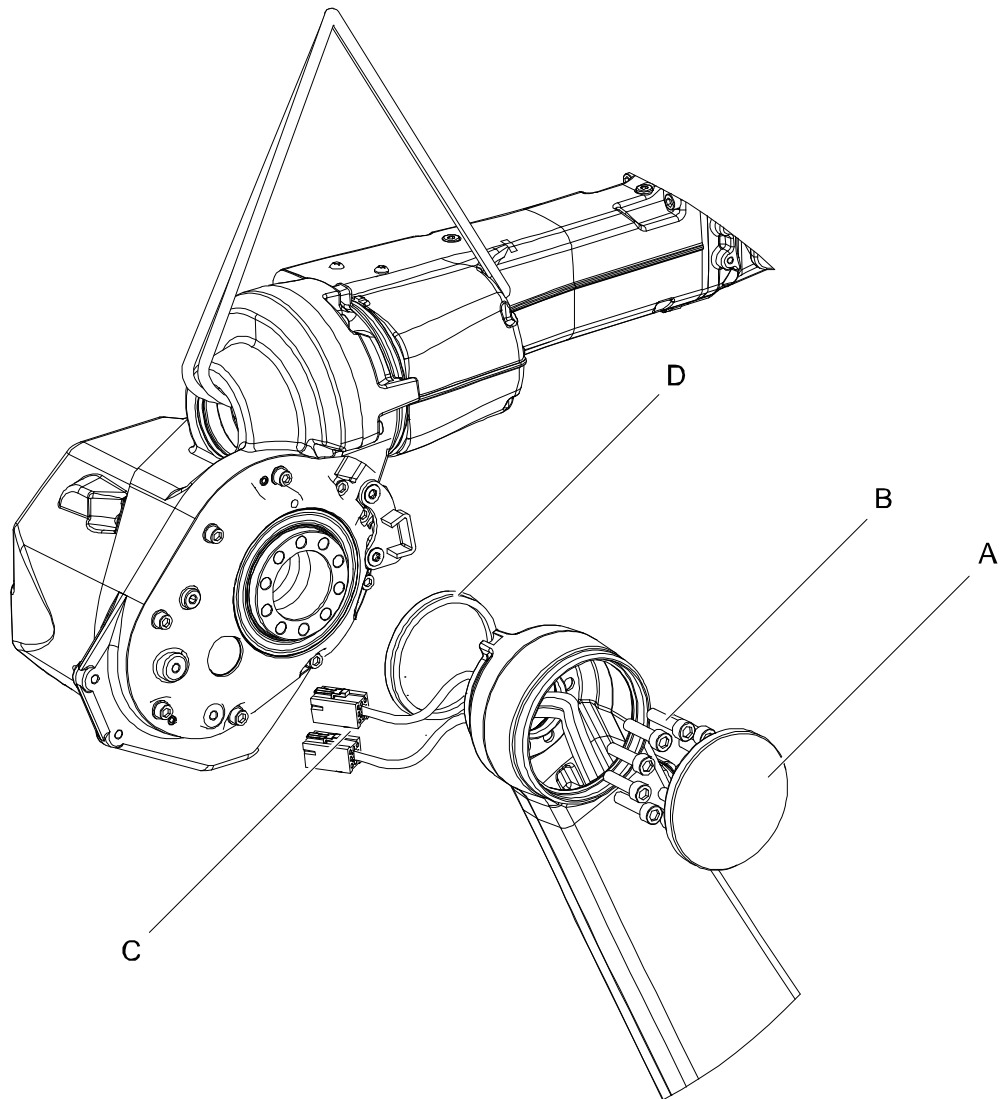

xx0700000045

A	VK -Cover
B	Socket head cap screw M10x40
C	Cable harness
D	V-ring

*Continues on next page*



## Required equipment

Equipment	Art. no.	Note
Upper arm, spare	For spare part number, see: <ul style="list-style-type: none"> <li>• <a href="#">Spare part lists on page 387</a>.</li> </ul>	Includes the wrist unit. All gearboxes are filled with oil at delivery.
VK-cover	3HAA2166-23	
Gasket, customer connections	3HAC 022050-001	Replace if damaged
Standard toolkit	-	Content is defined in section <a href="#">Standard tools on page 383</a> .

**CAUTION**

Always cut the paint with a knife and grind the paint edge when disassembling parts. See [Cut the paint or surface on the robot before replacing parts on page 159](#).

## Deciding calibration routine

Decide which calibration routine to be used, based on the information in the table. Depending on which routine is chosen, action might be required prior to beginning the repair work of the robot, see the table.

	Action	Note
1	Decide which calibration routine to use for calibrating the robot. <ul style="list-style-type: none"> <li>• Reference calibration. External cable packages (DressPack) and tools can stay fitted on the robot.</li> <li>• Fine calibration. All external cable packages (DressPack) and tools must be removed from the robot.</li> </ul>	
	<p><b>If the robot is to be calibrated with reference calibration:</b></p> <p>Find previous reference values for the axis or create new reference values. These values are to be used after the repair procedure is completed, for calibration of the robot.</p> <p>If no previous reference values exist, and no new reference values can be created, then reference calibration is not possible.</p>	<p>Follow the instructions given in the reference calibration routine on the FlexPendant to create reference values.</p> <p>Creating new values requires possibility to move the robot.</p> <p>Read more about reference calibration for Axis Calibration in <a href="#">Reference calibration routine on page 350</a>.</p> <p>Read more about reference calibration for Pendulum Calibration in <i>Operating manual - Calibration Pendulum</i>.</p>
	<p><b>If the robot is to be calibrated with fine calibration:</b></p> <p>Remove all external cable packages (DressPack) and tools from the robot.</p>	

Continues on next page



## 4 Repair

### 4.4.2 Replacing the complete upper arm, IRB 1600ID/1660ID

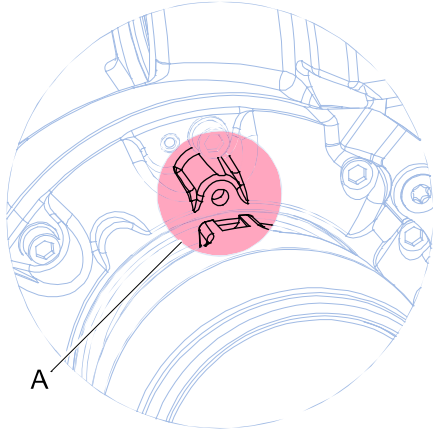

*Continued*

#### Removing the complete upper arm

Use this procedure to remove the complete upper arm.

	Action	Note
1	Decide which calibration routine to use, and take actions accordingly prior to beginning the repair procedure.	
2	Put the robot in synchronization position for Axis 3.	 <p data-bbox="959 965 1066 981">xx070000075</p> <p data-bbox="991 1003 1353 1025">A Synchronization mark Axis 3</p>
3	 <b>DANGER</b> Turn off all: <ul data-bbox="496 1173 826 1272" style="list-style-type: none"><li>• electric power supply</li><li>• hydraulic pressure supply</li><li>• air pressure supply</li></ul> to the robot, before entering the robot working area.	

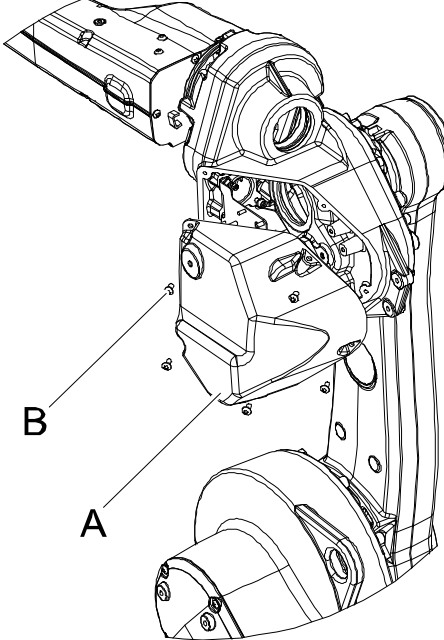
*Continues on next page*

	Action	Note
4	Remove the <i>cover arm housing</i> .	 <p data-bbox="991 965 1098 987">xx0700000077</p> <p data-bbox="1023 1003 1294 1066"> <b>A</b> Cover Arm Housing  <b>B</b> Torx pan head screw         </p>
5	Disconnect all connectors inside the arm-house and loosen the cabling from straps and brackets.	Described in section <a href="#">Replacing the cable harness, IRB 1600 on page 162</a>
6	 <p data-bbox="580 1205 694 1238"><b>CAUTION</b></p> <p data-bbox="491 1263 951 1352">The robot upper arm weighs 39 kg. All lifting accessories used must be sized accordingly!</p>	

Continues on next page

## 4 Repair

### 4.4.2 Replacing the complete upper arm, IRB 1600ID/1660ID

Continued

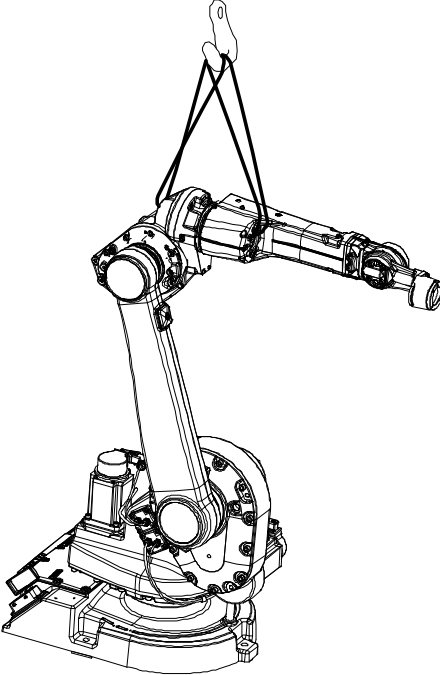
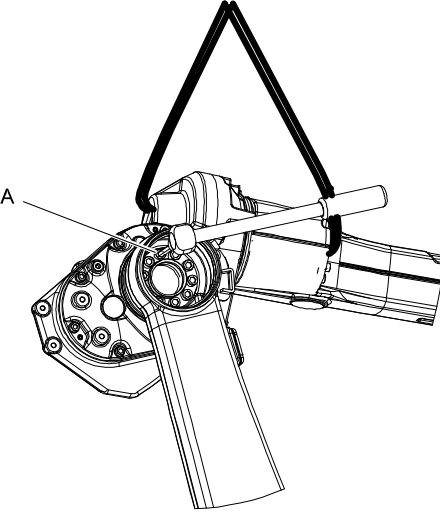
Action	Note
<p>7 Secure the weight of the upper arm with a roundsling. Apply the roundsling through the hole in the upper arm. See figure!</p>	 <p>xx070000060</p>
<p>8 Knock out the VK-cover from the motor side.</p>	
<p>9 Remove the 10 attachment screws (A) and the single washer, use standard tools.</p>	 <p>xx070000057</p> <p>A Socket head cap screw M10x40</p>
<p>10 Carefully lift away the upper arm and put it somewhere safe.</p>	

Continues on next page

Refitting the complete upper arm

Use this procedure to refit the complete upper arm.

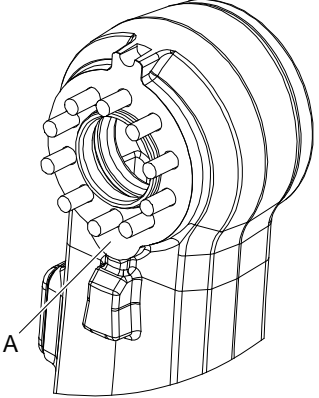
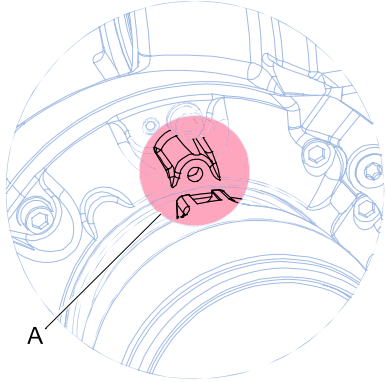
	Action	Note
1	 <b>CAUTION</b> The robot upper arm weighs 39 kg. All lifting accessories used must be sized accordingly!	
2	Attach a roundsling to the upper arm and lift it.	
3	Clean the contact surface.	 <p data-bbox="1027 1111 1134 1128">xx0700000076</p> <p data-bbox="1059 1144 1283 1173"><b>A Contact surface.</b></p>
4	Carefully refit the upper arm to the lower arm, making sure that the new upper arm is mounted in the synchronization position.	 <p data-bbox="1027 1599 1134 1617">xx0700000075</p> <p data-bbox="1059 1637 1422 1666"><b>A Synchronization mark Axis 3</b></p>

Continues on next page

## 4 Repair

### 4.4.2 Replacing the complete upper arm, IRB 1600ID/1660ID

Continued

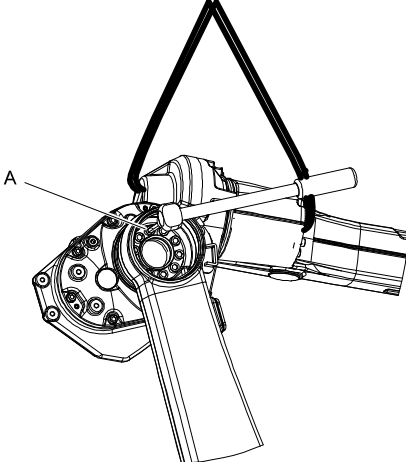
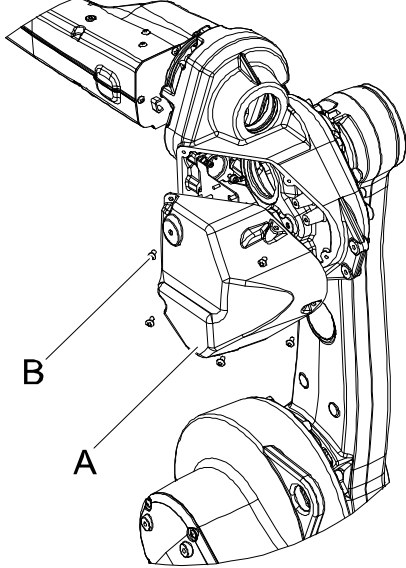
Action	Note
<p>5 Refit the 10 attachment screws (A) and the single washer, use standard tools. Tightening torque: 70 Nm.</p>	 <p>xx0700000057</p> <p>A Socket head cap screw M10x40</p>
<p>6 Run the cabling through the lower arm and into the arm housing.</p>	
<p>7 Connect all the connectors in the armhouse and secure the cabling with brackets and straps.</p>	
<p>8 Refit the cover arm housing to the upper arm <a href="#">Standard tools on page 383</a>.</p>	 <p>xx0700000077</p> <p>A Cover Arm Housing B Torx pan head screw</p>
<p>9 Refit a new VK-cover to the lower arm. replace it, if damaged.</p>	<p>Spare part no. is specified in <a href="#">Required equipment on page 189</a>.</p>

Continues on next page

	Action	Note
10	Recalibrate the robot.	<p>Pendulum Calibration is described in <i>Operating manual - Calibration Pendulum</i>, enclosed with the calibration tools.</p> <p>Axis Calibration is described in <i>Calibrating with Axis Calibration method on page 349</i>.</p> <p>General calibration information is included in section <i>Calibration on page 337</i>.</p>
11	 <b>DANGER</b> Make sure all safety requirements are met when performing the first test run. These are further detailed in the section <i>First test run may cause injury or damage on page 28</i> .	

## 4 Repair

### 4.4.3 Replacing the complete lower arm

### 4.4.3 Replacing the complete lower arm

#### Location of lower arm

The lower arm is located on the robot as shown in the figure.

A more detailed view of the lower arm may be found in the spare part view, *Spare parts - Lower arm, exploded view*.

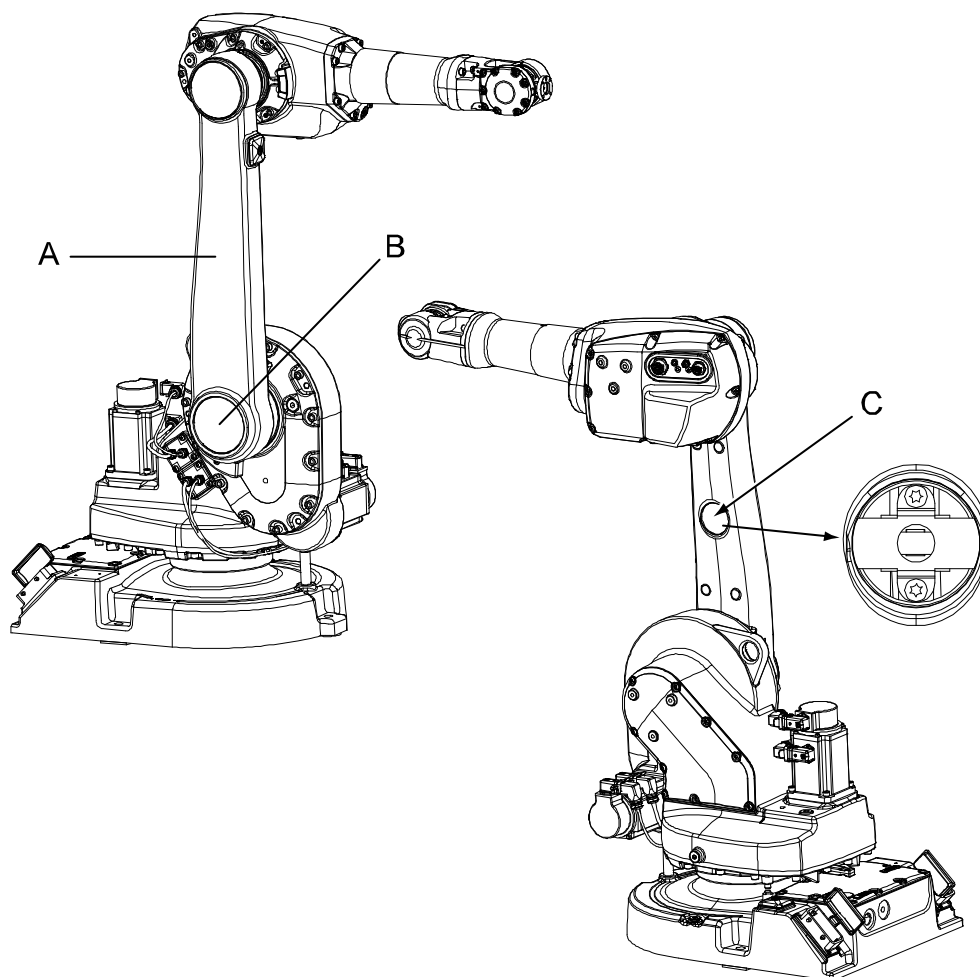

xx0400001246

A	Lower arm
B	VK-cover
C	VK-cover, middle

#### Required equipment

Equipment	Art. no.	Note
Lower arm	See <a href="#">Spare part lists on page 387</a> .	
VK-cover	3HAA2166-23	
VK-cover	3HAA2166-21	In the middle of the lower arm.

*Continues on next page*



Equipment	Art. no.	Note
Sealing ring (V-ring)	3HAB3732-13	Replace if damaged.
Isopropanol	-	Used to clean the mating surfaces.
Locking liquid	-	Loctite 574
Standard toolkit	-	Content is defined in section <a href="#">Standard tools on page 383</a> .
Other tools and procedures may be required. See references to these procedures in the step-by-step instructions below.		These procedures include references to the tools required.

**CAUTION**

Always cut the paint with a knife and grind the paint edge when disassembling parts. See [Cut the paint or surface on the robot before replacing parts on page 159](#).

**Deciding calibration routine**

Decide which calibration routine to be used, based on the information in the table. Depending on which routine is chosen, action might be required prior to beginning the repair work of the robot, see the table.

	Action	Note
1	Decide which calibration routine to use for calibrating the robot. <ul style="list-style-type: none"> <li>Reference calibration. External cable packages (DressPack) and tools can stay fitted on the robot.</li> <li>Fine calibration. All external cable packages (DressPack) and tools must be removed from the robot.</li> </ul>	
	<p><b>If the robot is to be calibrated with reference calibration:</b></p> <p>Find previous reference values for the axis or create new reference values. These values are to be used after the repair procedure is completed, for calibration of the robot.</p> <p>If no previous reference values exist, and no new reference values can be created, then reference calibration is not possible.</p>	<p>Follow the instructions given in the reference calibration routine on the FlexPendant to create reference values.</p> <p>Creating new values requires possibility to move the robot.</p> <p>Read more about reference calibration for Axis Calibration in <a href="#">Reference calibration routine on page 350</a>.</p> <p>Read more about reference calibration for Pendulum Calibration in <a href="#">Operating manual - Calibration Pendulum</a>.</p>
	<p><b>If the robot is to be calibrated with fine calibration:</b></p> <p>Remove all external cable packages (DressPack) and tools from the robot.</p>	

Continues on next page





## 4 Repair

### 4.4.3 Replacing the complete lower arm

*Continued*

#### Removing the lower arm

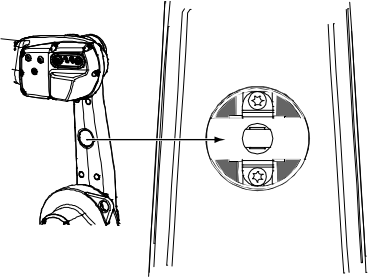

Use this procedure to remove the lower arm.

	Action	Note
1	Decide which calibration routine to use, and take actions accordingly prior to beginning the repair procedure.	
2	 <b>DANGER</b> Turn off all: <ul style="list-style-type: none"> <li>• electric power supply</li> <li>• hydraulic pressure supply</li> <li>• air pressure supply</li> </ul> to the robot, before entering the robot working area.	
3	Remove the complete upper arm.	See section <a href="#">Replacing the complete upper arm, IRB 1600ID/1660ID on page 188.</a>
4	Remove the VK-covers.  <b>CAUTION</b> Be careful not to damage the cabling and cable bracket inside the lower arm when removing the middle VK-cover! The figure to the right shows the space underneath the cover. The gray areas are safe for insertion of a tool that may be inserted with a maximum depth of 20 mm!	Shown in the figure <a href="#">Location of lower arm on page 196.</a>  <small>xx0400001247</small>
5	Pull down the cabling through the lower arm and pull it out.	
6	 <b>CAUTION</b> The robot lower arm weighs 20 kg. All lifting accessories used must be sized accordingly!	
7	Fit the lifting device to the lower arm to secure the weight of the arm.	
8	Unscrew the 12 attachment screws and remove the single washer.	
9	Gently pull out the cabling while lifting away the lower arm. Be careful with the connectors, they are sensitive to damage!	
10	Check the <i>sealing ring</i> . Replace it if damaged.	Spare part no. is specified in <a href="#">Required equipment on page 196.</a>

*Continues on next page*

## Refitting the lower arm

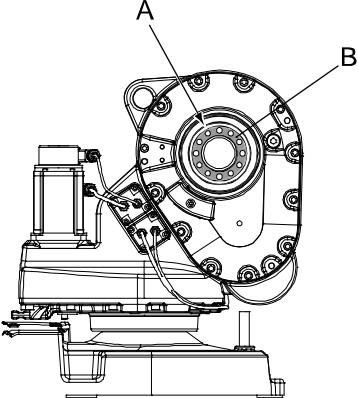
Use this procedure to refit the complete lower arm.

	Action	Note
1	Clean the mating surfaces on both the lower arm and on the frame with isopropanol. Also clean the area where the sealing ring is fitted.	
2	Fit the <i>sealing ring</i> properly to the frame. Replace it if damaged.	<p>Spare part no. is specified in <a href="#">Required equipment on page 196</a>.</p>  <p>xx0400001245</p> <ul style="list-style-type: none"> <li>• A: Sealing ring</li> <li>• B: Mating surface</li> </ul>
3	Lubricate the mating surface on the frame with Loctite 574.	
4	 <b>CAUTION</b> The robot lower arm weighs 20 kg. All lifting accessories used must be sized accordingly!	
5	Fit the lifting device to the lower arm and lift it into position.	
6	Insert the cabling into the lower arm.	
7	Fit the lower arm against the frame, fit the washer and secure with the 12 attachment screws.	12 pcs; M10 x 40, tightening torque: 70 Nm.
8	Push the cabling up through the lower arm and place the cable bracket inside the lower arm correctly.	
9	Fit new <i>VK-covers</i> to the lower arm. Make sure that the cable bracket inside the lower arm is secured beneath the middle <i>VK-cover</i> .	Spare part no. is specified in <a href="#">Required equipment on page 196</a> .
10	Refit the upper arm.	See section <a href="#">Replacing the complete upper arm, IRB 1600ID/1660ID on page 188</a> .

Continues on next page

## 4 Repair

### 4.4.3 Replacing the complete lower arm

*Continued*

	Action	Note
11	Recalibrate the robot!	<p>Pendulum Calibration is described in <i>Operating manual - Calibration Pendulum</i>, enclosed with the calibration tools.</p> <p>Axis Calibration is described in <a href="#">Calibrating with Axis Calibration method on page 349</a>.</p> <p>General calibration information is included in section <a href="#">Calibration on page 337</a>.</p>
12	 <b>DANGER</b> Make sure all safety requirements are met when performing the first test run. These are further detailed in the section <a href="#">First test run may cause injury or damage on page 28</a> .	

#### 4.4.4 Replacing the wrist unit, IRB 1600

##### Location of wrist unit

The wrist unit is located in the frontmost part of the upper arm.

A more detailed view of the upper arm, including the wrist unit, is found in the spare part view, see *Spare parts - Upper arm, exploded view*.

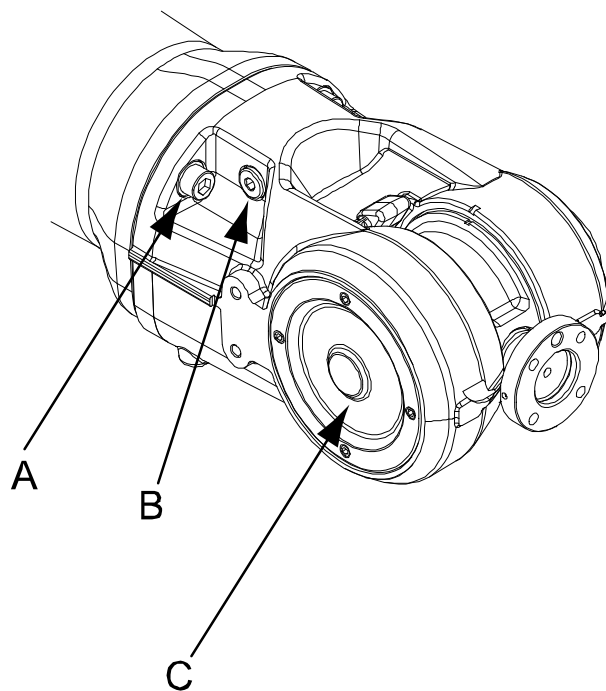

xx0600002847

A	Attachment screws, wrist unit (3 pcs)
B	Oil plug (only one shown)
C	Wrist unit

##### Required equipment

Equipment, etc.	Spare part no.	Art. no.	Note
Wrist Standard/Foundry	3HAC027003-001		Standard and Foundry versions. O-ring sealing plate not included! <b>Note!</b> The wrist, standard/Foundry is not interchangeable with art. no. 3HAC 10475-1!
O-ring sealing plate	3HAC025420-001		Must be replaced. <b>Note!</b> The o-ring sealing plate is not interchangeable with art.no. 3HAC 7191-1!
Grease		3HAC 3537-1	For lubricating the o-ring sealing plate.
Standard toolkit			Content is defined in section <a href="#">Standard tools on page 383</a> .

*Continues on next page*

## 4 Repair

### 4.4.4 Replacing the wrist unit, IRB 1600

Continued

Equipment, etc.	Spare part no.	Art. no.	Note
Other tools and procedures may be required. See references to these procedures in the step-by-step instructions below.			These procedures include references to the tools required.



#### CAUTION

Always cut the paint with a knife and grind the paint edge when disassembling parts. See [Cut the paint or surface on the robot before replacing parts on page 159](#).

#### Deciding calibration routine

Decide which calibration routine to be used, based on the information in the table. Depending on which routine is chosen, action might be required prior to beginning the repair work of the robot, see the table.



	Action	Note
1	Decide which calibration routine to use for calibrating the robot. <ul style="list-style-type: none"> <li>Reference calibration. External cable packages (DressPack) and tools can stay fitted on the robot.</li> <li>Fine calibration. All external cable packages (DressPack) and tools must be removed from the robot.</li> </ul>	
	<p><b>If the robot is to be calibrated with reference calibration:</b></p> <p>Find previous reference values for the axis or create new reference values. These values are to be used after the repair procedure is completed, for calibration of the robot.</p> <p>If no previous reference values exist, and no new reference values can be created, then reference calibration is not possible.</p>	<p>Follow the instructions given in the reference calibration routine on the FlexPendant to create reference values.</p> <p>Creating new values requires possibility to move the robot.</p> <p>Read more about reference calibration for Axis Calibration in <a href="#">Reference calibration routine on page 350</a>.</p> <p>Read more about reference calibration for Pendulum Calibration in <i>Operating manual - Calibration Pendulum</i>.</p>
	<p><b>If the robot is to be calibrated with fine calibration:</b></p> <p>Remove all external cable packages (DressPack) and tools from the robot.</p>	

#### Removal, wrist unit

The procedure below details how to remove the complete wrist unit.

	Action	Note
1	Decide which calibration routine to use, and take actions accordingly prior to beginning the repair procedure.	

Continues on next page

	Action	Note
2	 <b>DANGER</b> Turn off all: <ul style="list-style-type: none"> <li>• electric power supply</li> <li>• hydraulic pressure supply</li> <li>• air pressure supply</li> </ul> to the robot, before entering the robot working area.	
3	 <b>CAUTION</b> Always cut the paint with a knife and grind the paint edge when disassembling parts. See <i>Cut the paint or surface on the robot before replacing parts on page 159</i> .	
4	Drain the oil from the wrist unit.	Detailed in section <i>Changing the oil in axes 5 and 6 gearboxes on page 138</i> .
5	Remove the wrist unit by unscrewing its three attachment screws.	Shown in the figure in section <i>Location of wrist unit on page 201</i> .

### Refitting, wrist unit

The procedure below details how to refit the complete wrist unit.



	Action	Note
1	Clean the joints that have been opened. See <i>Cut the paint or surface on the robot before replacing parts on page 159</i>	
2	Move the robot to a position where the upper arm is vertical.	
3	 <b>DANGER</b> Turn off all: <ul style="list-style-type: none"> <li>• electric power supply</li> <li>• hydraulic pressure supply</li> <li>• air pressure supply</li> </ul> to the robot, before entering the robot working area.	

Continues on next page

## 4 Repair

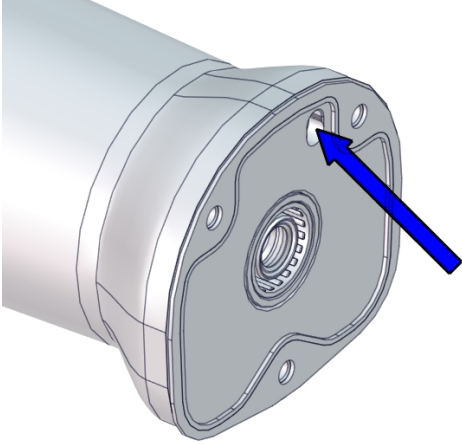

### 4.4.4 Replacing the wrist unit, IRB 1600

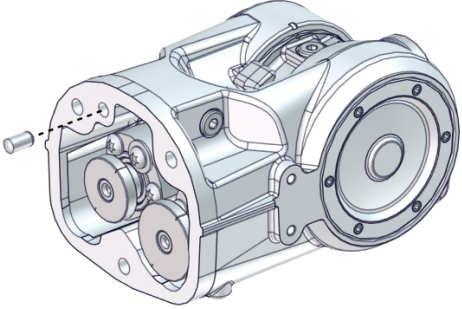
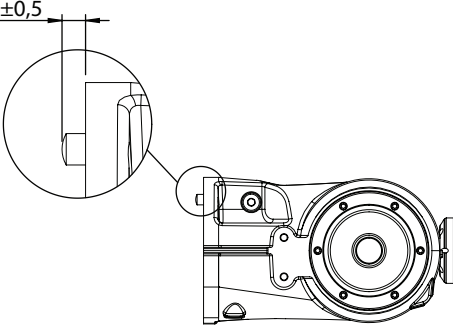
Continued

	Action	Note
4	<p>With the new spare part wrist there is a parallel pin enclosed.</p> <p>The parallel pin must be installed on the wrist if the robot is calibrated with the Axis Calibration method.</p> <p>If the calibration method is unknown, look at the tubular shaft interface. If it has an elongated hole, install the parallel pin into the wrist, according to the next step.</p>	 <p>xx1700000117</p>
5	<p>If the robot is calibrated with Axis Calibration, fit the parallel pin into the corresponding hole in the wrist.</p> <p> <b>Note</b></p> <p>If the parallel pin is not installed on a robot calibrated with Axis Calibration, the calibration result will be affected negatively.</p>	 <p>xx1700000118</p> <p>Verify that the parallel pin sticks out from the wrist according to the measurement given below.</p> <p><math>6 \pm 0,5</math></p>  <p>xx1700000119</p>
6	<p>Lightly lubricate the o-ring sealingplate with <i>grease</i>.</p>	<p>Art. no. is specified in section <a href="#">Required equipment on page 201</a>.</p>
7	<p>In order to release the brake, connect the 24 VDC power supply to motors:</p>	<p>Connect to connector R3.MP5 or 6:</p> <ul style="list-style-type: none"> <li>• +: pin 7</li> <li>• -: pin 8</li> </ul>
8	<p>Fit the <i>o-ring sealingplate</i> to the upper arm. Fit the <i>wrist unit</i> to the upper arm with the three attachment screws, while making sure that the gears mate properly.</p>	<p>Use a new o-ring! Spare part no. is specified in <a href="#">Required equipment on page 201</a>.</p> <p>3 pcs, M8 x 25, tightening torque: 28 Nm.</p>

Continues on next page



	Action	Note
9	Perform a leak-down test.	Detailed in section <a href="#">Performing a leak-down test on page 154</a> .
10	Refill the wrist unit with oil.	Detailed in section <a href="#">Changing the oil in axes 5 and 6 gearboxes on page 138</a> .
11	<p>Seal and paint the joints that have been opened. See <a href="#">Cut the paint or surface on the robot before replacing parts on page 159</a></p> <p> <b>Note</b></p> <p>After all repair work, wipe the robot free from particles with spirit on a lint free cloth.</p>	
12	Recalibrate the robot!	<p>Pendulum Calibration is described in <i>Operating manual - Calibration Pendulum</i>, enclosed with the calibration tools.</p> <p>Axis Calibration is described in <a href="#">Calibrating with Axis Calibration method on page 349</a>.</p> <p>General calibration information is included in section <a href="#">Calibration on page 337</a>.</p>
13	<p> <b>DANGER</b></p> <p>Make sure all safety requirements are met when performing the first test run. These are further detailed in the section <a href="#">First test run may cause injury or damage on page 28</a>.</p>	

## 4 Repair

### 4.4.5 Replacing the wrist unit, IRB 1600ID

### 4.4.5 Replacing the wrist unit, IRB 1600ID



#### Note

After replacement of motors/motor or gearbox in a manipulator, recalibration is required.

#### Location of wrist unit

The wrist unit is located in the frontmost part of the upper arm.

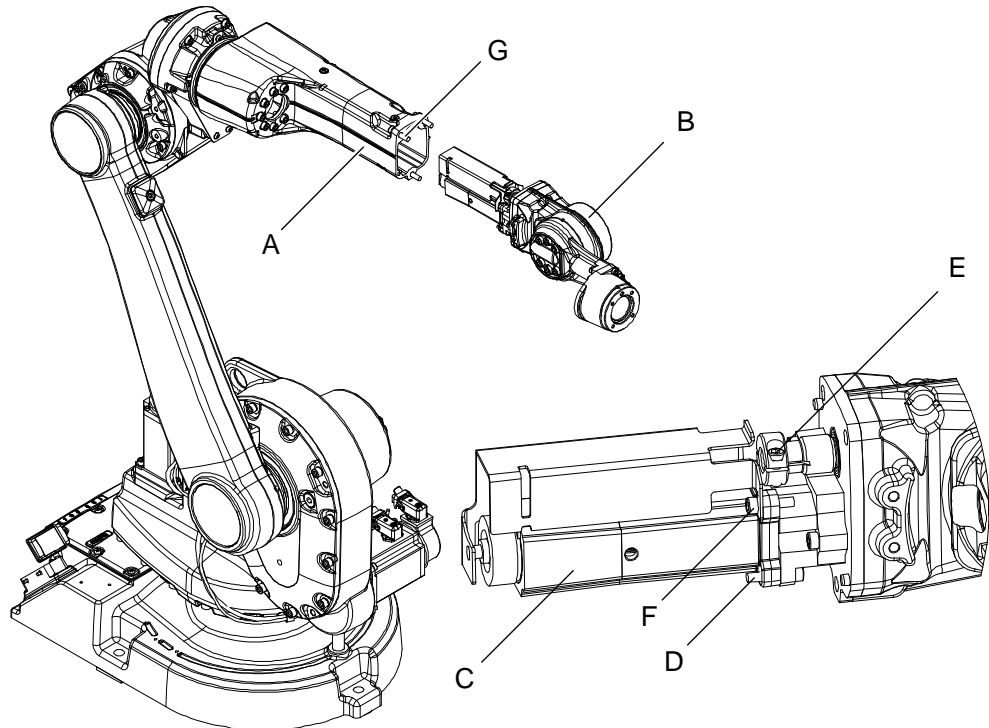

xx070000025

A	Upper arm
B	Wrist
C	Motor axis 6
D	Hexagon socket head screw M5x25
E	Hexagon socket head screw M5X16 (10.9) (Short head)
F	Hexagon socket head screw M5x25
G	Hexagon socket head screw M8x35

#### Required equipment

Equipment	Art. No.	Note
Wrist, ID	See <a href="#">Spare part lists on page 387</a> .	
O-ring		

Continues on next page

Equipment	Art. No.	Note
Grease	3HAC3537-1	For lubricating the o-ring sealing plate.
Arm	3HAC9037-1	For adjusting the gear play, motor/pinion.
Loctite 242	1269-0014-410	
Standard toolkit		Content is defined in section <a href="#">Standard tools on page 383</a> .
Other tools and procedures may be required. See references to these procedures in the step-by-step instructions below.		These procedures include references to the tools required.

**CAUTION**

Always cut the paint with a knife and grind the paint edge when disassembling parts. See [Cut the paint or surface on the robot before replacing parts on page 159](#).

**Deciding calibration routine**

Decide which calibration routine to be used, based on the information in the table. Depending on which routine is chosen, action might be required prior to beginning the repair work of the robot, see the table.

	Action	Note
1	Decide which calibration routine to use for calibrating the robot. <ul style="list-style-type: none"> <li>Reference calibration. External cable packages (DressPack) and tools can stay fitted on the robot.</li> <li>Fine calibration. All external cable packages (DressPack) and tools must be removed from the robot.</li> </ul>	
	<b>If the robot is to be calibrated with reference calibration:</b> Find previous reference values for the axis or create new reference values. These values are to be used after the repair procedure is completed, for calibration of the robot. If no previous reference values exist, and no new reference values can be created, then reference calibration is not possible.	Follow the instructions given in the reference calibration routine on the FlexPendant to create reference values. Creating new values requires possibility to move the robot. Read more about reference calibration for Axis Calibration in <a href="#">Reference calibration routine on page 350</a> . Read more about reference calibration for Pendulum Calibration in <i>Operating manual - Calibration Pendulum</i> .
	<b>If the robot is to be calibrated with fine calibration:</b> Remove all external cable packages (DressPack) and tools from the robot.	

Continues on next page

## 4 Repair

### 4.4.5 Replacing the wrist unit, IRB 1600ID



Continued

#### Removing the wrist unit

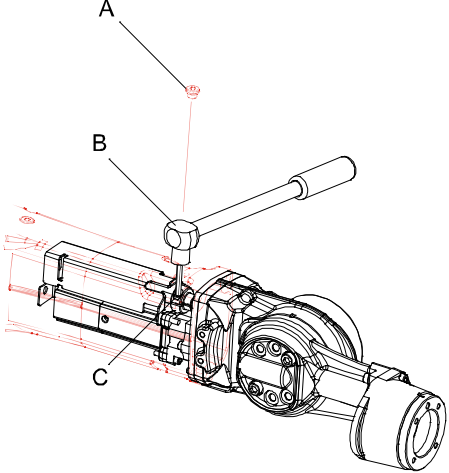
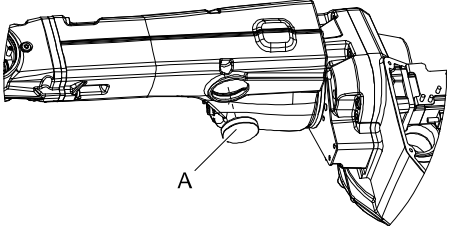
Use this procedure to remove the complete wrist unit.

	Action	Note
1	Decide which calibration routine to use, and take actions accordingly prior to beginning the repair procedure.	
2	 <p><b>DANGER</b></p> <p>Turn off all:</p> <ul style="list-style-type: none"> <li>• electric power supply</li> <li>• hydraulic pressure supply</li> <li>• air pressure supply</li> </ul> <p>to the robot, before entering the robot working area.</p>	
3	Remove all extra equipment fitted on upper arm and wrist.	Shown in <a href="#">Remove AW Gun on page 229</a>
4	The plug (A) in figure covering the screw (C). Remove the plug using standard tools (B). Remove the screw for looking of motor axis 5, (C) in figure <a href="#">Location of wrist unit on page 206</a> .	 <p>xx070000092</p> <p>A Plug            B Standard tool, <a href="#">Standard tools on page 383</a>            C Hexagon socket head screw M5X16 (Short head)</p>
5	Remove the VK-Cover.	 <p>xx070000054</p> <p>A VK-Cover</p>
6	Gently pull the cables out through the hole for the VK- cover in the armtube.	

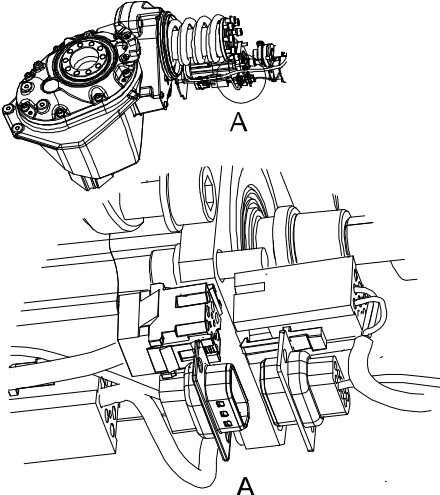
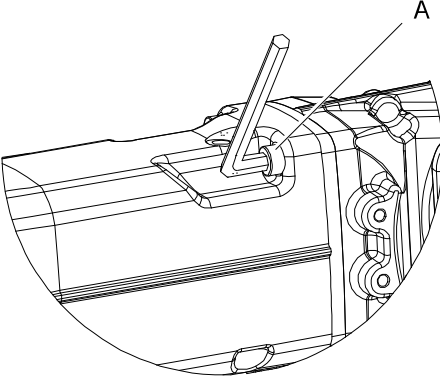
Continues on next page

Action	Note
<p>7 Disconnect the connectors R4.FB6 and R4.MP6 to motor axis 6, through the hole for the VK cover.</p>	 <p>xx0700000053</p> <ul style="list-style-type: none"> <li>• A: Connectors R4.FB6 &amp; R4.MP6</li> </ul>
<p>8 Remove the attachment screws securing the wrist.</p>	 <p>xx0700000052</p> <ul style="list-style-type: none"> <li>• A: Hex socket head cap screw M8x35 quality 8.8-A2F (3 pcs)</li> </ul>
<p>9 Remove the wrist with motor 6 from the upper arm tube and put it on a work bench or similar.</p> <p> <b>CAUTION</b></p> <p>Be careful when handling the wrist. Always hold on the casting, do not hold on the wrist cover. This can damage the sealing which will cause oil leakage.</p>	

*Continues on next page*

## 4 Repair

### 4.4.5 Replacing the wrist unit, IRB 1600ID

Continued

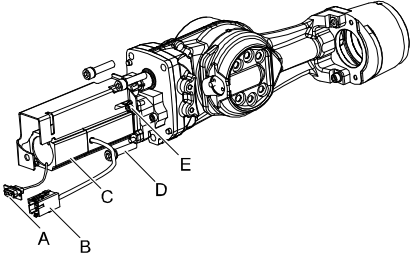

Action	Note
<p>10 Remove the three screws, hexagon socket head screw M5x25 (E) securing the motor axis 6 and remove the motor (C).</p>	 <p>xx070000091</p> <p>A: Contact R4.FB6            B: Contact R4.MP6            C: Motor axis 6            D: Hexagon socket head screw M8x35            F: Hexagon socket head screw M5x25</p>

### Refitting the wrist unit

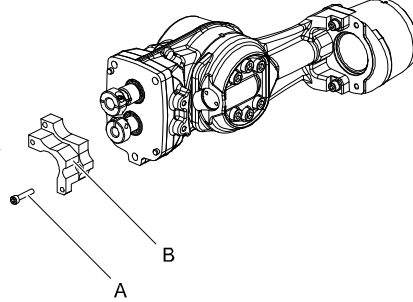
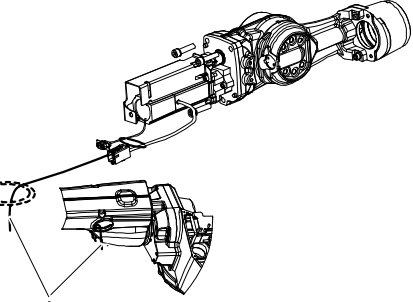
Use this procedure to refit the complete wrist unit.

Action	Note
<p>1  <b>Note</b></p> <p>Remove the console from the old motor and scrap it.</p> <p>The new console shall be fitted to the axis-6 motor. See .</p>	 <p>xx0700000353</p> <p>A Hex socket head cap screw M5x25            B Motor Console</p>
<p>2 Apply a string or similar to the cable harness and run it out through the hole for the VK cover.</p>	
<p>3 Carefully fit the wrist (with motor axis 6 fitted) to the upper arm tube, using the string to pull the cable harness back through the hole for the VK cover.</p>	 <p>xx070000093</p> <p>A: String</p>

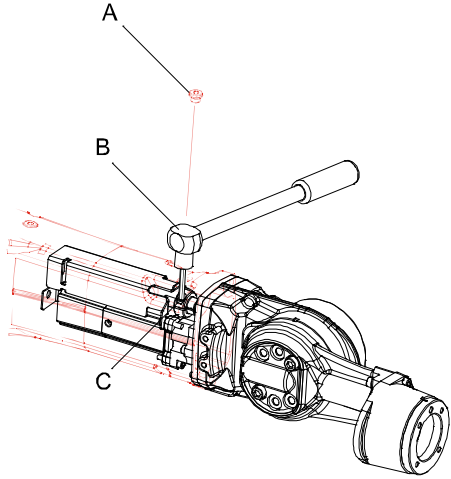
Continues on next page

Action	Note
4 Use standard tools to refit the three hexagon socket head screw (M8x35).	Shown as (H) in figure <a href="#">Location of wrist unit on page 206</a> . <b>Tightening torque 24 Nm</b>
5 Reconnect connectors R4.FB6 and R4.MP6, through the hole for the VK cover.	 <b>Note</b> When reconnecting the connectors R4.FB6 and R4.MP6, make sure to push the connectors towards the wrist as far away from the axis 5-6 cable spiral as possible, to avoid grease to accumulate on the resolver connector.
6 Tighten the hexagon socket head screw M5X16 (Short head).	Shown as (E) in figure <a href="#">Location of wrist unit on page 206</a> . <b>Tightening torque 6 Nm</b>
7 Refit the VK cover.	
8 Tightening the plug (A). <b>Tightening torque 6 Nm</b>	 <p style="text-align: right; font-size: small;">xx070000092</p>
9 Refit the AW equipment in the upper arm.	Shown in <a href="#">Refitting the wrist unit on page 210</a>
10 Recalibrate the robot.	Pendulum Calibration is described in <a href="#">Operating manual - Calibration Pendulum</a> , enclosed with the calibration tools. Axis Calibration is described in <a href="#">Calibrating with Axis Calibration method on page 349</a> . General calibration information is included in section <a href="#">Calibration on page 337</a> .
11  <b>DANGER</b> Make sure all safety requirements are met when performing the first test run. These are further detailed in section <a href="#">First test run may cause injury or damage on page 28</a> .	

## 4 Repair

### 4.4.6 Replacing the wrist unit, IRB1660ID

### 4.4.6 Replacing the wrist unit, IRB1660ID

#### Location of wrist unit

The wrist unit is located in the frontmost part of the upper arm, as shown in the figure.

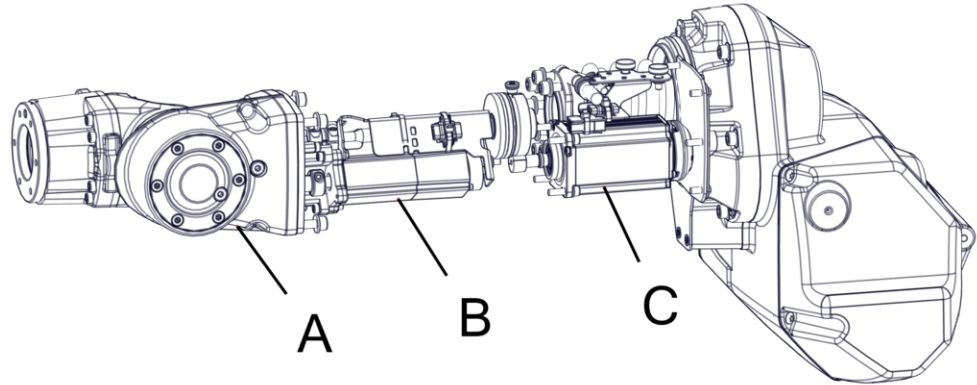

xx1500002930

A	Wrist
B	Motor axis 6
C	Motor axis 5

#### Required equipment

Equipment	Art. no.	Note
Motor, axis 6	For spare part number, see: <ul style="list-style-type: none"><li>• <a href="#">Spare part lists on page 387.</a></li></ul>	
Wrist unit, ID	For spare part number, see: <ul style="list-style-type: none"><li>• <a href="#">Spare part lists on page 387</a></li></ul>	
VK-cover	3HAA2166-18	Always replace with a new when removed.
Locking liquid	-	Loctite 574
Standard toolkit		Content is defined in section <a href="#">Standard tools on page 383.</a>
Other tools and procedures may be required. See references to these procedures in the step-by-step instructions below.		These procedures include references to the tools required.



#### CAUTION

Always cut the paint with a knife and grind the paint edge when disassembling parts. See [Cut the paint or surface on the robot before replacing parts on page 159.](#)

*Continues on next page*



**Deciding calibration routine**

Decide which calibration routine to be used, based on the information in the table. Depending on which routine is chosen, action might be required prior to beginning the repair work of the robot, see the table.

	Action	Note
1	Decide which calibration routine to use for calibrating the robot. <ul style="list-style-type: none"> <li>Reference calibration. External cable packages (DressPack) and tools can stay fitted on the robot.</li> <li>Fine calibration. All external cable packages (DressPack) and tools must be removed from the robot.</li> </ul>	
	<b>If the robot is to be calibrated with reference calibration:</b> Find previous reference values for the axis or create new reference values. These values are to be used after the repair procedure is completed, for calibration of the robot. If no previous reference values exist, and no new reference values can be created, then reference calibration is not possible.	Follow the instructions given in the reference calibration routine on the FlexPendant to create reference values. Creating new values requires possibility to move the robot. Read more about reference calibration for Axis Calibration in <a href="#">Reference calibration routine on page 350</a> . Read more about reference calibration for Pendulum Calibration in <i>Operating manual - Calibration Pendulum</i> .
	<b>If the robot is to be calibrated with fine calibration:</b> Remove all external cable packages (DressPack) and tools from the robot.	

**Removing wrist unit**

Use this procedure to remove the wrist unit.

	Action	Information
1	Decide which calibration routine to use, and take actions accordingly prior to beginning the repair procedure.	
2	Move the upper arm to synchronization position.	
3	 <b>DANGER</b> Turn off all: <ul style="list-style-type: none"> <li>electric power supply</li> <li>hydraulic pressure supply</li> <li>air pressure supply</li> </ul> to the robot, before entering the robot working area.	
4	Remove all extra equipment fitted on the upper arm.	

Continues on next page



## 4 Repair

### 4.4.6 Replacing the wrist unit, IRB1660ID

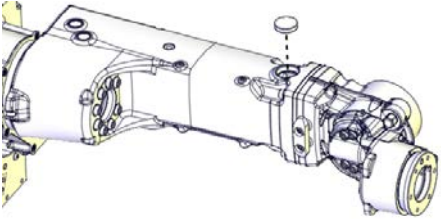
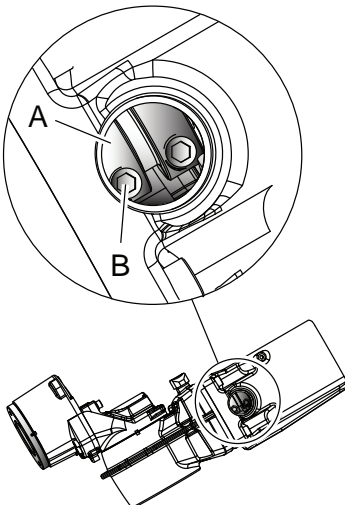
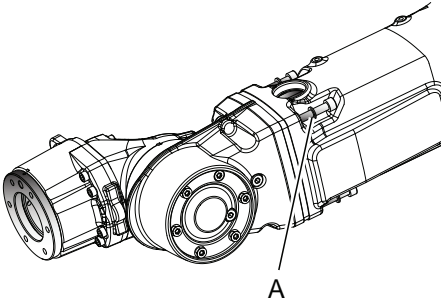
Continued

	Action	Information
5	Remove the VK-cover.	 <p>xx100000873</p>
6	Open the flexible coupling securing motor axis 5, on the side facing the wrist.	 <p>xx100000874</p> <ul style="list-style-type: none"><li>• A: Coupling</li><li>• B: Attachment screw</li></ul>
7	Remove the attachment screws securing the wrist.	 <p>xx100000875</p> <ul style="list-style-type: none"><li>• A: Attachment screws (4 pcs)</li></ul>

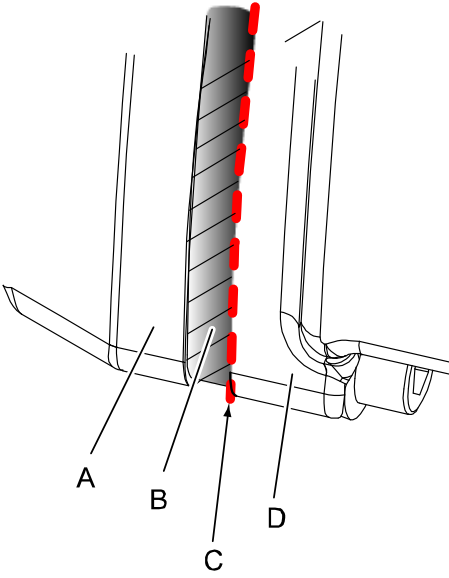
Continues on next page

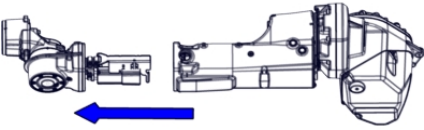
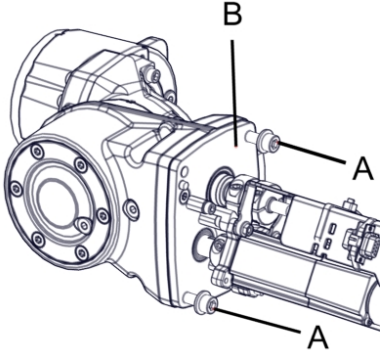
	Action	Information
8	<p>Separate the wrist and upper arm tube at the marked division point (along the dotted line in the figure).</p> <p> <b>Note</b></p> <p>There is oil inside the wrist. The cover is only secured with Loctite 574. If opened in the wrong place, oil will spill out.</p>	 <p>xx100000933</p> <ul style="list-style-type: none"> <li>• A: Wrist</li> <li>• B: Cover (Secured with Loctite 574 to the wrist)</li> <li>• C: Division point</li> <li>• D: Upper arm tube</li> </ul>
9	<p>Pull carefully out the wrist a little to reach the motor cables to motor axis 6.</p> <p> <b>Note</b></p> <p>The wrist is fitted on cylindrical pins.</p>	 <p>xx1500001259</p>
10	<p>Fit two short screws in the holes for the attachment screws to temporarily secure the cover.</p>	 <p>xx1500003257</p> <ul style="list-style-type: none"> <li>• A: Short screws (2 pcs)</li> <li>• B: Cover</li> </ul>

Continues on next page

## 4 Repair

### 4.4.6 Replacing the wrist unit, IRB1660ID

Continued

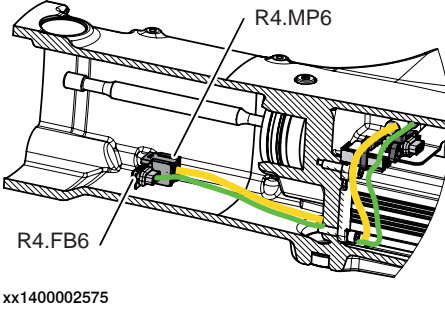
	Action	Information
11	Disconnect the cables R4.MP6 and R4.FB6 to motor axis 6.	 <p>xx1400002575</p>
12	Put the wrist with motor axis 6 on a work bench.	
13	Remove motor axis 6 from the wrist.	For details, see <a href="#">Replacement of motor, axis 6, IRB 1660ID</a> on page 319.

### Refitting wrist unit

Use this procedure to refit the wrist unit.

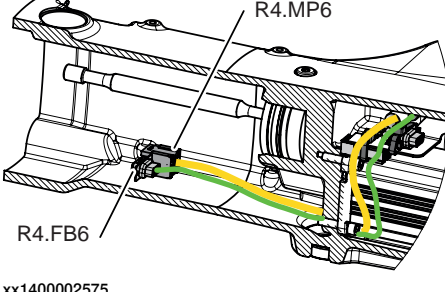
	Action	Information
1	Clean all assembly surfaces. Remove any painting from the assembly surfaces, with a knife.	
2	Refit motor axis 6 to the wrist.	For details, see <a href="#">Replacement of motor, axis 6, IRB 1660ID</a> on page 319.
3	Place the wrist with motor axis 6 fitted a little into the upper arm tube.	
4	Reconnect the cables R4.MP6 and R4.FB6 to motor axis 6.	 <p>xx1400002575</p>

Continues on next page

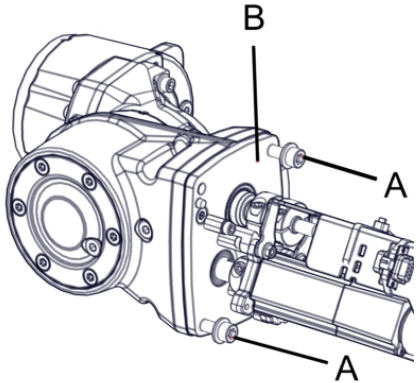
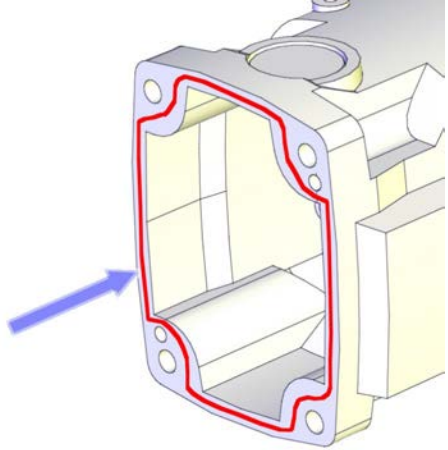
	Action	Information
5	Remove the two short screws used to temporarily secure the cover.	 <p>xx1500003257</p> <ul style="list-style-type: none"> <li>• A: Short screws (2 pcs)</li> <li>• B: Cover</li> </ul>
6	Apply locking liquid to the assembly surface on the upper arm tube.	<p>The locking liquid is specified in <a href="#">Required equipment on page 212</a>.</p>  <p>xx1200000063</p>

Continues on next page

## 4 Repair

### 4.4.6 Replacing the wrist unit, IRB1660ID

Continued

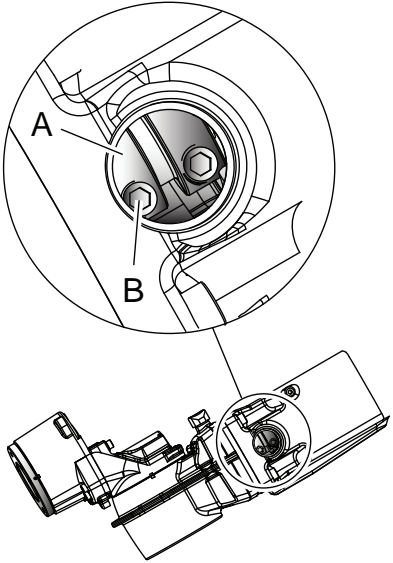
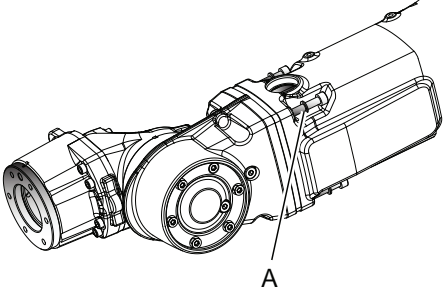
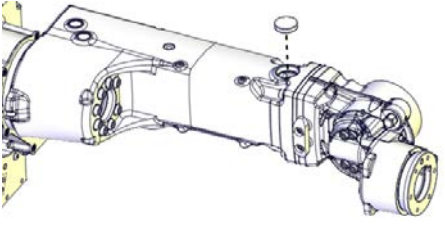
	Action	Information
7	<p>Push the wrist with motor axis 6 into its position onto the cylindrical pins.</p> <p> <b>Tip</b></p> <p>Look through the hole for the VK-cover when fitting the axis into the flexible coupling of motor axis 5.</p>	 <p>xx100000874</p> <ul style="list-style-type: none"> <li>• A: Flexible coupling axis 5</li> <li>• B: Attachment screw</li> </ul>
8	<p>Secure the wrist with its attachment screws and washers.</p>	<p>Tightening torque: 35 Nm</p>  <p>xx100000875</p> <ul style="list-style-type: none"> <li>• A: Attachment screws (4 pcs)</li> </ul>
9	<p>Secure the flexible coupling axis 5 with its attachment screw.</p>	<p>Tightening torque: 14 Nm</p>
10	<p>Fit a new VK-cover.</p>	<p>Article number is specified in <a href="#">Required equipment on page 212</a>.</p>  <p>xx100000873</p>

Continues on next page

	Action	Information
11	Recalibrate the robot.	Pendulum Calibration is described in <i>Operating manual - Calibration Pendulum</i> , enclosed with the calibration tools. Axis Calibration is described in <a href="#">Calibrating with Axis Calibration method on page 349</a> . General calibration information is included in section <a href="#">Calibration on page 337</a> .
12	 <b>DANGER</b> Make sure all safety requirements are met when performing the first test run. These are further detailed in the section <a href="#">First test run may cause injury or damage on page 28</a> .	

## 4 Repair

### 4.4.7 Replacing the damper, axis 2

### 4.4.7 Replacing the damper, axis 2

#### Location of damper, axis 2

The damper, axis 2, is located as shown in the figure.

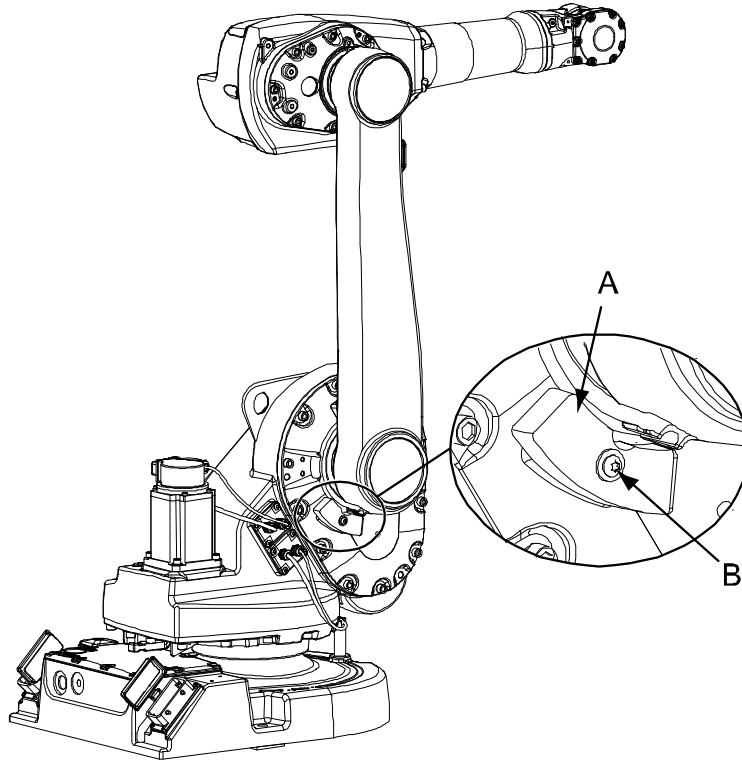

xx0400001217

A	Damper, axis 2
B	Attachment screw and washer

#### Required equipment

Equipment, etc.	Art. no.	Note
Damper, axis 2	3HAC022013-001	
Standard toolkit	-	Content is defined in section <a href="#">Standard tools on page 383</a> .
Other tools and procedures may be required. See references to these procedures in the step-by-step instructions below.		These procedures include references to the tools required.



#### CAUTION



Always cut the paint with a knife and grind the paint edge when disassembling parts. See [Cut the paint or surface on the robot before replacing parts on page 159](#).

*Continues on next page*





### Removing the damper

Use this procedure to remove the damper.

	Action	Note
1	 <b>CAUTION</b> Always cut the paint with a knife and grind the paint edge when disassembling parts. See <a href="#">Cut the paint or surface on the robot before replacing parts on page 159</a> .	
2	Run the robot to a position where it is best to enable access to the attachment screw of the damper.	
3	 <b>DANGER</b> Turn off all: <ul style="list-style-type: none"> <li>• electric power supply</li> <li>• hydraulic pressure supply</li> <li>• air pressure supply</li> </ul> to the robot, before entering the robot working area.	
4	Remove the damper by unscrewing the attachment screw and washer.	

### Refitting the damper

Use this procedure to refit the damper.

	Action	Note
1	Run the robot to a position where it is best to enable access to the attachment screw of the damper.	
2	 <b>DANGER</b> Turn off all: <ul style="list-style-type: none"> <li>• electric power supply</li> <li>• hydraulic pressure supply</li> <li>• air pressure supply</li> </ul> to the robot, before entering the robot working area.	
3	Secure the damper with the attachment screw and washer.	1 pc: M6 x 16.
4	 <b>DANGER</b> Make sure all safety requirements are met when performing the first test run. These are further detailed in the section <a href="#">First test run may cause injury or damage on page 28</a> .	

## 4 Repair

### 4.4.8 Replacing the damper, axis 3

### 4.4.8 Replacing the damper, axis 3

#### Location of damper, axis 3

The damper axis 3, is located as shown in the figure.

A more detailed view of the damper and its position may be found in the spare part view, see *Spare parts - Upper arm, exploded view*.

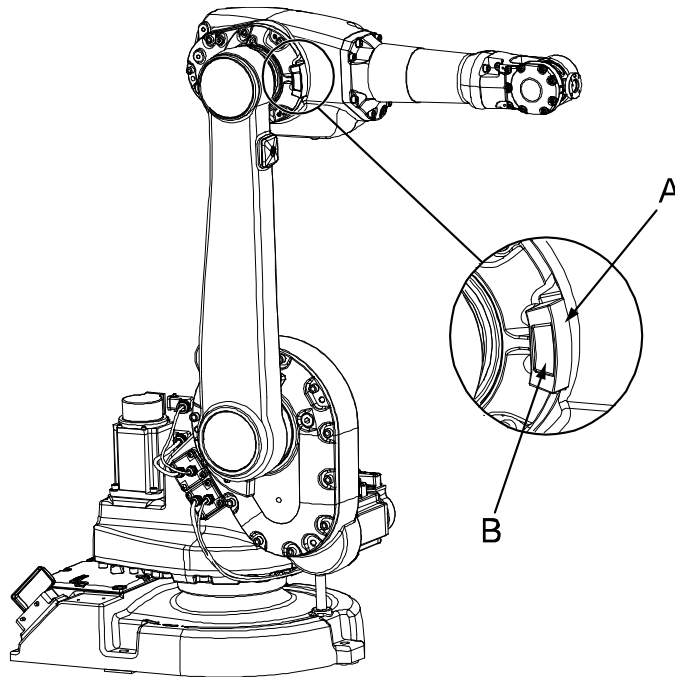

xx0400001215

A	Damper, axis 3
B	Cast tab

#### Required equipment

Equipment, etc.	Art. no.	Note
Damper, axis 3	3HAC022260-001	
Standard toolkit		Content is defined in section <a href="#">Standard tools on page 383</a> .



#### CAUTION

Always cut the paint with a knife and grind the paint edge when disassembling parts. See [Cut the paint or surface on the robot before replacing parts on page 159](#).

#### Removing the damper axis 3

Use this procedure to remove the damper.



	Action	Note
1	Run the robot to a position where it is best to enable access to the access 3 damper.	Shown in the figure <a href="#">Location of damper, axis 3 on page 222</a> .

*Continues on next page*

	Action	Note
2	 <b>DANGER</b> Turn off all: <ul style="list-style-type: none"> <li>• electric power supply</li> <li>• hydraulic pressure supply</li> <li>• air pressure supply</li> </ul> to the robot, before entering the robot working area.	
3	Remove the damper by gently prying it from the cast tab.	

### Refitting the damper axis 3

Use this procedure to refit the damper.

	Action	Note
1	Run the robot to a position where it is best to enable access to the location where the axis 3 damper is fitted.	Shown in the figure <a href="#">Location of damper, axis 3 on page 222</a> .
2	 <b>DANGER</b> Turn off all: <ul style="list-style-type: none"> <li>• electric power supply</li> <li>• hydraulic pressure supply</li> <li>• air pressure supply</li> </ul> to the robot, before entering the robot working area.	
3	Refit the damper by gently pressing it onto the cast tab on the upper arm.	
4	 <b>DANGER</b> Make sure all safety requirements are met when performing the first test run. These are further detailed in the section <a href="#">First test run may cause injury or damage on page 28</a> .	

## 4 Repair

### 4.4.9 Replacing the mechanical stop axis 3, IRB 1600ID/1660ID

### 4.4.9 Replacing the mechanical stop axis 3, IRB 1600ID/1660ID

#### Location of the mechanical stop axis 3

The mechanical stop axis 3 is located as shown in the figure.

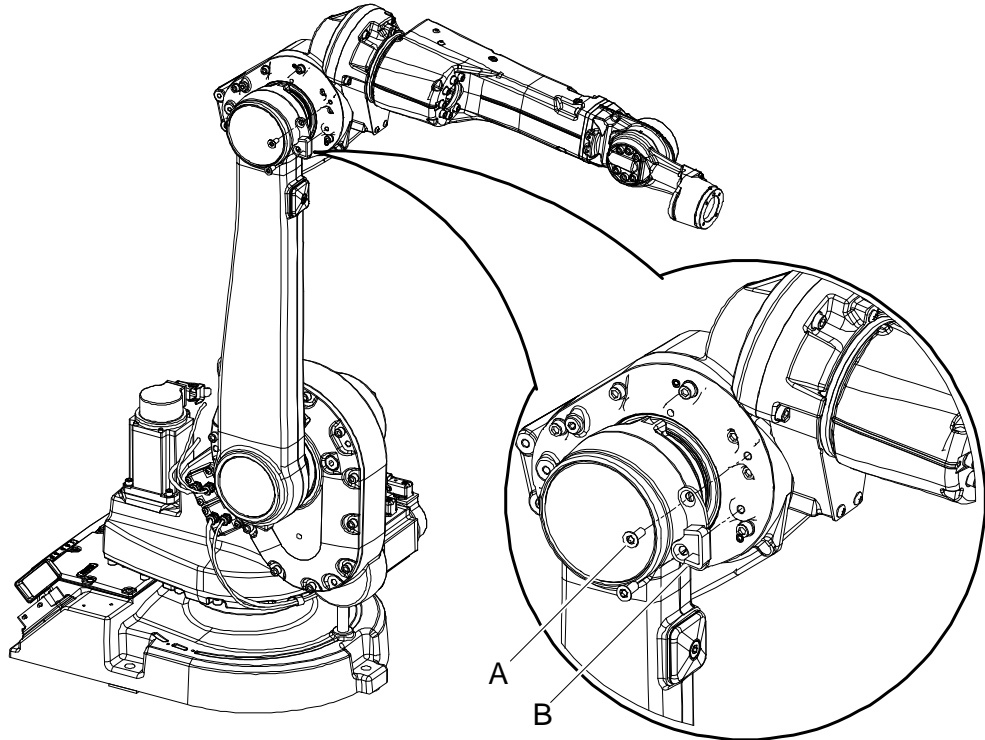

xx070000043

A	Torx counters. head screw
B	Mechanical damper

#### Required equipment

Equipment	Art. no.	Note
Mechanical stop	See <a href="#">Spare part lists on page 387</a> .	
Standard tools		Content is defined in section <a href="#">Standard tools on page 383</a> .



#### CAUTION

Always cut the paint with a knife and grind the paint edge when disassembling parts. See [Cut the paint or surface on the robot before replacing parts on page 159](#).

*Continues on next page*

**Removing the mechanical stop axis 3**

Use this procedure to remove the mechanical stop.

	Action	Note
1	Run the robot to a position that enables access to the mechanical stop.	
2	 <b>DANGER</b> Turn off all: <ul style="list-style-type: none"> <li>• electric power supply</li> <li>• hydraulic pressure supply</li> <li>• air pressure supply</li> </ul> to the robot, before entering the robot working area.	
3	Remove the mechanical stop.	

**Refitting the mechanical stop axis 3**

Use this procedure to refit the mechanical stop.

	Action	Note
1	Refit the mechanical stop with its attachment screws.	
2	 <b>DANGER</b> Make sure all safety requirements are met when performing the first test run. These are further detailed in the section <a href="#">First test run may cause injury or damage on page 28</a> .	

## 4 Repair

### 4.4.10 Replacement of damper, axis 5

#### 4.4.10 Replacement of damper, axis 5

##### Location of damper, axis 5

The damper, axis 5, is located as shown in the figure below!

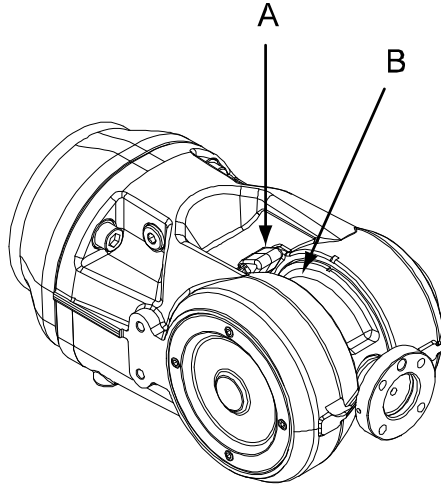

xx0600002806

A	Damper, axis 5
B	Recess

##### Required equipment

Equipment, etc.	Spare part no.	Note
Damper, axis 5	3HAB 8964-1	
Standard toolkit		Content is defined in section <a href="#">Standard tools on page 383</a> .



##### CAUTION

Always cut the paint with a knife and grind the paint edge when disassembling parts. See [Cut the paint or surface on the robot before replacing parts on page 159](#).

##### Removal, damper axis 5

The procedure below details how to remove the damper, axis 5.



	Action	Note
1	Run the robot to a position that enables the end of the <i>damper</i> to be pushed into the <i>recess</i> in the wrist unit.	Shown in the figure <a href="#">Location of damper, axis 5 on page 226</a> .

*Continues on next page*

	Action	Note
2	 <b>DANGER</b> Turn off all: <ul style="list-style-type: none"> <li>• electric power supply</li> <li>• hydraulic pressure supply</li> <li>• air pressure supply</li> </ul> to the robot, before entering the robot working area.	
3	Unhook the end of the damper, and push it into the recess.	
4	Manually move the wrist (robot axis 5) away from the damper to pull it out.	

### Refitting, damper axis 5

The procedure below details how to refit the damper, axis 5.

	Action	Note
1	 <b>DANGER</b> Turn off all: <ul style="list-style-type: none"> <li>• electric power supply</li> <li>• hydraulic pressure supply</li> <li>• air pressure supply</li> </ul> to the robot, before entering the robot working area.	
2	Push the end of the damper into the gap between the wrist unit and upper arm.	Make sure the damper is turned the correct way!
3	Manually move the wrist (robot axis 5) in order to pull the damper into position.	
4	Fold out the damper hooks to secure it in position.	
5	 <b>DANGER</b> Make sure all safety requirements are met when performing the first test run. These are further detailed in the section <a href="#">First test run may cause injury or damage on page 28</a> .	

## 4 Repair

### 4.4.11 Remove upper arm AW Gun

#### 4.4.11 Remove upper arm AW Gun

##### Location of AW Gun

The location of the AW equipment.

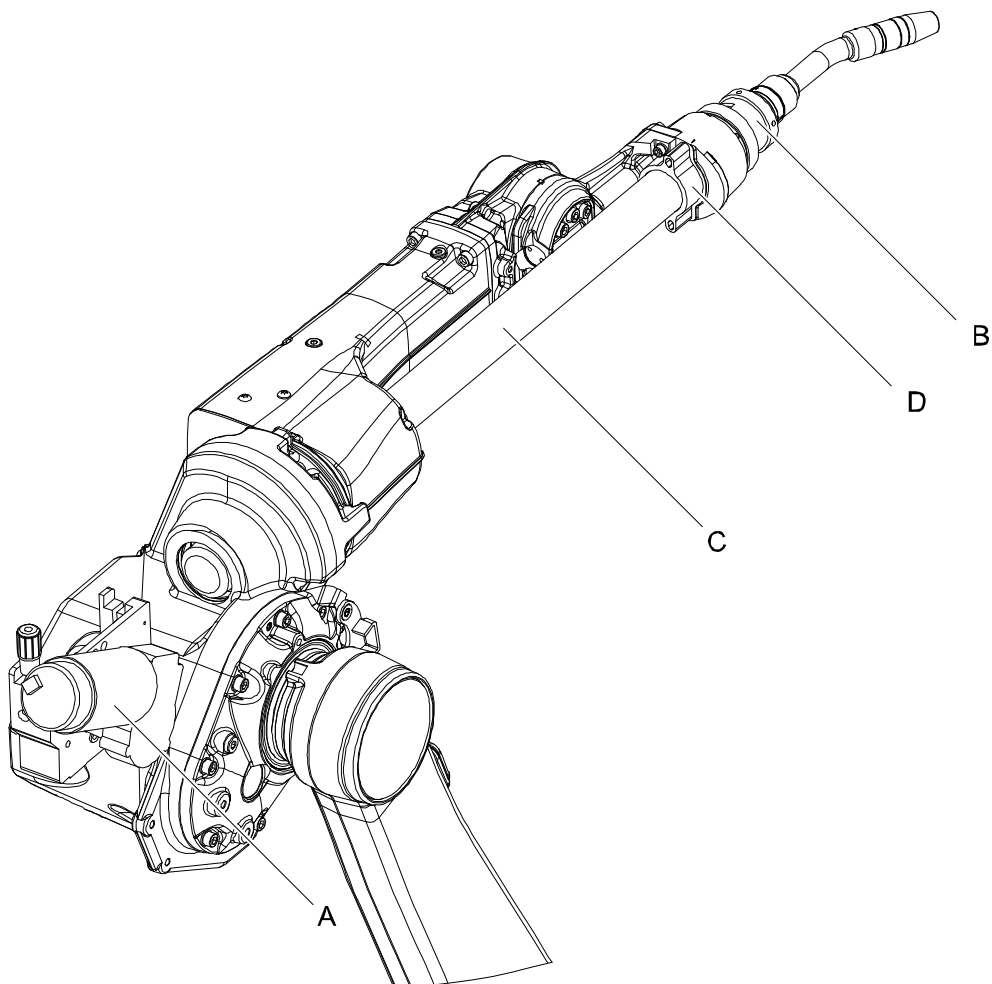

xx0700000153

A	Wire feeder (customer option)
B	Weld gun (BINZEL)
C	Welding cable (BINZEL)
D	Brace (BINZEL)

##### Required equipment

Equipment	Art. no.	Note
Standard tools	-	<a href="#">Standard tools on page 383.</a>



##### CAUTION

Always cut the paint with a knife and grind the paint edge when disassembling parts. See [Cut the paint or surface on the robot before replacing parts on page 159.](#)

*Continues on next page*



Remove AW Gun

The section below shows how to remove the AW. equipment from the upper arm of an IRB 1600 ID.

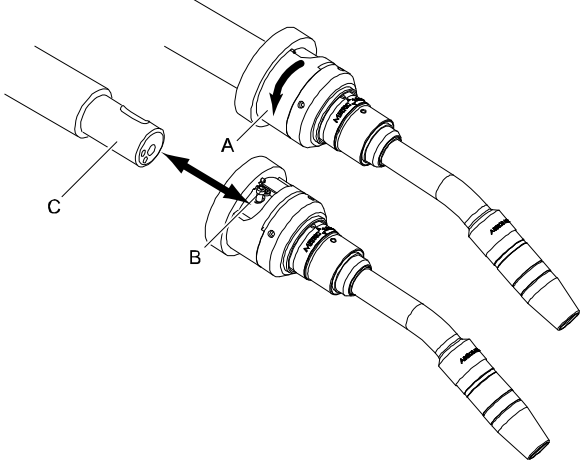
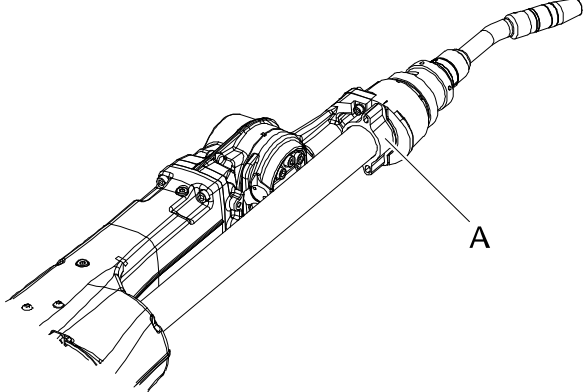
	Action	Note
1	 <b>DANGER</b> Turn off all: <ul style="list-style-type: none"> <li>• electric power supply</li> <li>• hydraulic pressure supply</li> <li>• air pressure supply</li> </ul> to the robot, before entering the robot working area.	
2	Remove the welding cable (C) from the weld gun by twisting the locking sleeve (A) counter clockwise. Loosen the locking screw (B) and pull out the welding cable.	 <p>xx0700000151</p> <p>A Locking sleeve B Locking screw C Welding cable</p>
3	Remove the two screws holding the brace.	 <p>xx0700000273</p> <p>A BINZEL Brace</p>

Continues on next page

## 4 Repair

### 4.4.11 Remove upper arm AW Gun

Continued

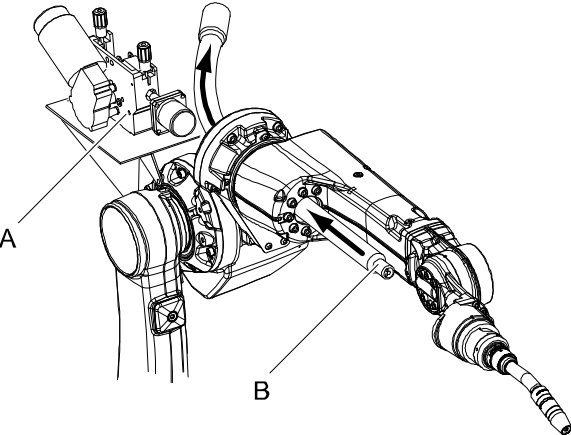
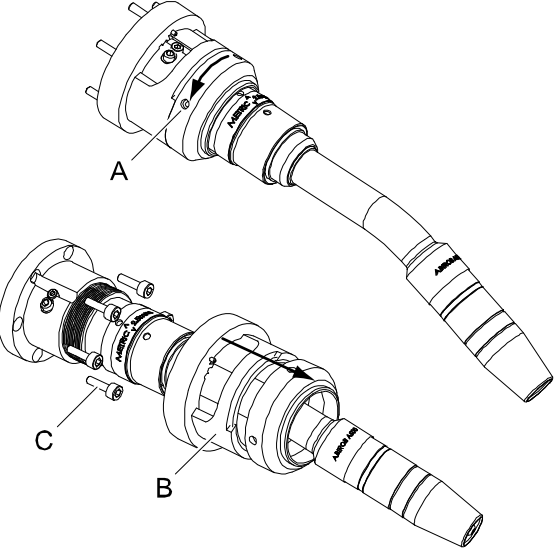
	Action	Note
4	Remove the welding cable from the wire feeder and pull it out.	 <p>xx0700000142</p> <p>A Wire feeder B Welding cable</p>
5	The locking ring (A) has a thread, loosen it counter clockwise and remove it. Remove the locking sleeve (B). Remove all 6x M5 screw (C).	 <p>xx0700000150</p> <p>A Locking ring B Locking sleeve C Screw M5</p>

Continues on next page

Refit AW Gun

The section below shows how to refit the AW. equipment to the upper arm of a IRB 1600 ID.

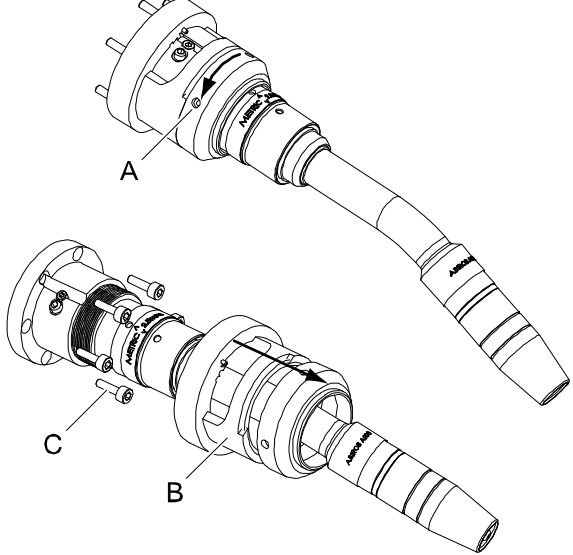
	Action	Note
1	 <b>DANGER</b> Turn off all: <ul style="list-style-type: none"> <li>• electric power supply</li> <li>• hydraulic pressure supply</li> <li>• air pressure supply</li> </ul> to the robot, before entering the robot working area.	
2	Refit the welding gun using the 6X Socket head cap screw M5 (C). Refit the locking sleeve (B). Lock the sleeve using the locking ring (A).	 <p>xx0700000150</p> <p>A Locking ring                      B Locking sleeve                      C Screw M5</p>

Continues on next page

## 4 Repair

### 4.4.11 Remove upper arm AW Gun

Continued

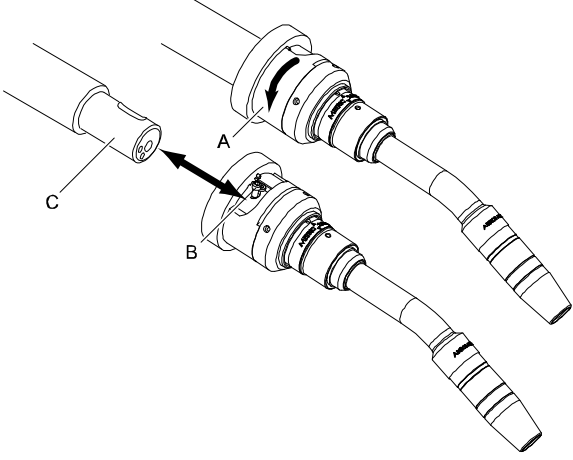
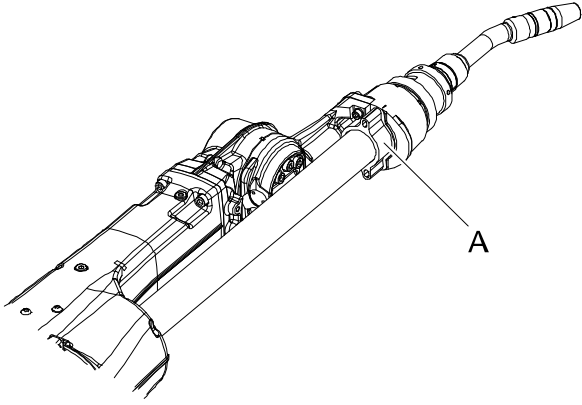
	Action	Note
3	Refit the welding cable (C). Lock the cable using the screw (B).	 <p data-bbox="826 779 933 801">xx0700000151</p> <p data-bbox="858 815 1066 913">A Locking sleeve B Locking screw C Welding cable</p>
4	Refit the brace (A).	 <p data-bbox="826 1330 933 1352">xx0700000273</p>

### 4.4.12 Measuring the play 1600ID/1660ID, axis 5

#### General

This section is only valid for IRB 1600ID/1660ID.

After reassembly due to repair work or any other reason, the play in axis 5 and 6 must be checked to ensure the repetition accuracy of the robot positioning.

#### Required equipment

Equipment, etc.	Art. no.	Note
Standard toolkit	-	Content is defined in section <a href="#">Standard tools on page 383</a> .
Turning disk adapter	3HAC027717-020	
Measuring tool	3HAB9238-1	For measuring play.
Measuring bracket	3HAC032976-001	
Dial indicator with a magnetic foot	-	
Other tools and procedures may be required. See references to these procedures in the step-by-step instructions below.		These procedures include references to the tools required.

#### Measurement, axis 5

Use this procedure to measure the play of axis 5.



	Action	Information
1	Move the robot to calibration position. Turn axis 4 to +90°.	
2	 <b>DANGER</b> Turn off all: <ul style="list-style-type: none"> <li>• electric power supply</li> <li>• hydraulic pressure supply</li> <li>• air pressure supply</li> </ul> to the robot, before entering the robot working area.	
3	Fit the <i>turning disk adapter</i> to the turning disk.	Art. no. is specified in <a href="#">Required equipment on page 233</a> .
4	Fit the <i>measuring tool</i> to the turning disk adapter.	Art. no. is specified in <a href="#">Required equipment on page 233</a> .

*Continues on next page*

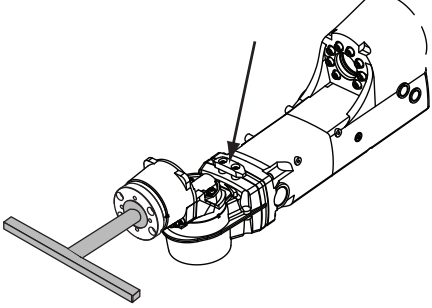

## 4 Repair

### 4.4.12 Measuring the play 1600ID/1660ID, axis 5

Continued

	Action	Information
5	Fit the <i>measuring bracket</i> to the wrist. Use the holes that are pointed out in the figure.	Art. no. is specified in <a href="#">Required equipment on page 233</a> .  xx1100000688
6	Fit the magnetic foot of the <i>dial indicator</i> on the measuring bracket.	
7	Place the tip of the dial indicator on the milled surface of the measuring tool shaft, as shown in the figure.	 xx1500000313
8	Verify that axis 5 is put in calibration position.	
9	Set the dial indicator to zero.	
10	Apply load $F$ with a dynamometer, as shown in the figure. <ul style="list-style-type: none"> <li>• IRB 1600ID-4/1.5: <math>F = 40\text{N}</math></li> <li>• IRB 1660ID-X/1.55: <math>F = 30\text{N}</math></li> </ul> Remove the load and make a note of the value from the dynamometer, as value $a1$ .	 xx1500000314

Continues on next page

	Action	Information
11	<p>Apply the same load in the opposite direction (180°), as shown in the figure.</p> <p>Remove the load and make a note of the value from the dynamometer, as value <math>a_2</math>.</p>	 <p>xx1500000315</p>
12	<p>Calculate the play in the axis as <math>a_1 + a_2</math>. The values of <math>a_1</math> and <math>a_2</math> are absolute values.</p>	<p>The maximum play allowed is:</p> <ul style="list-style-type: none"> <li>• IRB 1600ID-4/1.5: 0.34 mm</li> <li>• IRB 1660ID-X/1.55: 0.25 mm</li> </ul>
13	Turn on power.	
14	Turn axis 5 to +90°.	
15	<p> <b>DANGER</b></p> <p>Turn off all:</p> <ul style="list-style-type: none"> <li>• electric power supply</li> <li>• hydraulic pressure supply</li> <li>• air pressure supply</li> </ul> <p>to the robot, before entering the robot working area.</p>	
16	Repeat <a href="#">step 10</a> to <a href="#">step 12</a> .	
17	Turn on power.	
18	Turn axis 5 to -90°.	
19	<p> <b>DANGER</b></p> <p>Turn off all:</p> <ul style="list-style-type: none"> <li>• electric power supply</li> <li>• hydraulic pressure supply</li> <li>• air pressure supply</li> </ul> <p>to the robot, before entering the robot working area.</p>	
20	Repeat <a href="#">step 10</a> to <a href="#">step 12</a> .	

## 4 Repair

### 4.4.13 Measuring the play 1600ID/1660ID, axis 6

### 4.4.13 Measuring the play 1600ID/1660ID, axis 6

#### General

This section is only valid for IRB 1600ID/1660ID.

After reassembly due to repair work or any other reason, the play in axis 5 and 6 must be checked to ensure the repetition accuracy of the robot positioning.

#### Required equipment

Equipment, etc.	Art. no.	Note
Standard toolkit	-	Content is defined in section <a href="#">Standard tools on page 383</a> .
Turning disk adapter	3HAC027717-020	
Measuring tool	3HAB9238-1	For measuring play.
Measuring bracket	3HAC032976-001	
Dial indicator with magnetic foot	-	
Other tools and procedures may be required. See references to these procedures in the step-by-step instructions below.		These procedures include references to the tools required.



#### Measurement, axis 6

Use this procedure to measure the play of axis 6.

	Action	Information
1	Move the robot to calibration position. Turn axis 4 to +90°.	
2	 <b>DANGER</b> Turn off all: <ul style="list-style-type: none"><li>• electric power supply</li><li>• hydraulic pressure supply</li><li>• air pressure supply</li></ul> to the robot, before entering the robot working area.	
3	Fit the <i>turning disk adapter</i> to the turning disk.	Art. no. is specified in <a href="#">Required equipment on page 236</a> .
4	Fit the <i>measuring tool</i> to the turning disk adapter.	Art. no. is specified in <a href="#">Required equipment on page 236</a> .

*Continues on next page*

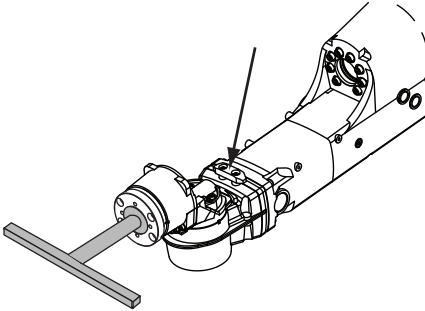



	Action	Information
5	Fit the <i>measuring bracket</i> to the wrist. Use the holes that are pointed out in the figure.	Art. no. is specified in <a href="#">Required equipment on page 236</a> .  xx1100000688
6	Fit the magnetic foot of the <i>dial indicator</i> on the measuring bracket.	
7	Place the tip of the dial indicator on the marking, as shown in the figure.	 xx1500000316
8	Verify that axis 6 is put in calibration position.	
9	Set the dial indicator to zero.	
10	Apply load $F=40N$ with a dynamometer on the opposite side of the dial indicator, as shown in the figure. Remove the load and make a note of the value from the dynamometer, as value <i>b1</i> .	 xx1500000317

Continues on next page

## 4 Repair

### 4.4.13 Measuring the play 1600ID/1660ID, axis 6

Continued

	Action	Information
11	<p>Apply load <math>F=40\text{N}</math> downwards on another side, as shown in the figure.</p> <p>Remove the load and make a note of the value from the dynamometer, as value <math>b2</math>.</p>	 <p>xx1500000318</p>
12	<p>Calculate the play in the axis as <math>b1 + b2</math>. The values of <math>b1</math> and <math>b2</math> are absolute values.</p>	<p>The maximum play allowed is:</p> <ul style="list-style-type: none"> <li>• IRB 1600ID-4/1.5: 0.25 mm</li> <li>• IRB 1660ID-X/1.55: 0.20 mm</li> </ul>
13	<p>Turn on power.</p>	
14	<p>Turn axis 6 to <math>+180^\circ</math>.</p>	
15	<p> <b>DANGER</b></p> <p>Turn off all:</p> <ul style="list-style-type: none"> <li>• electric power supply</li> <li>• hydraulic pressure supply</li> <li>• air pressure supply</li> </ul> <p>to the robot, before entering the robot working area.</p>	
16	<p>Repeat <a href="#">step 10</a> to <a href="#">step 12</a>.</p>	

4.5 Frame and base

4.5.1 Replacement of base

Location of base

The base is located at the bottom of the robot as shown in the figure below.

A more detailed view of the base may be found in the spare part view, see *Spare parts - Base, exploded view*.

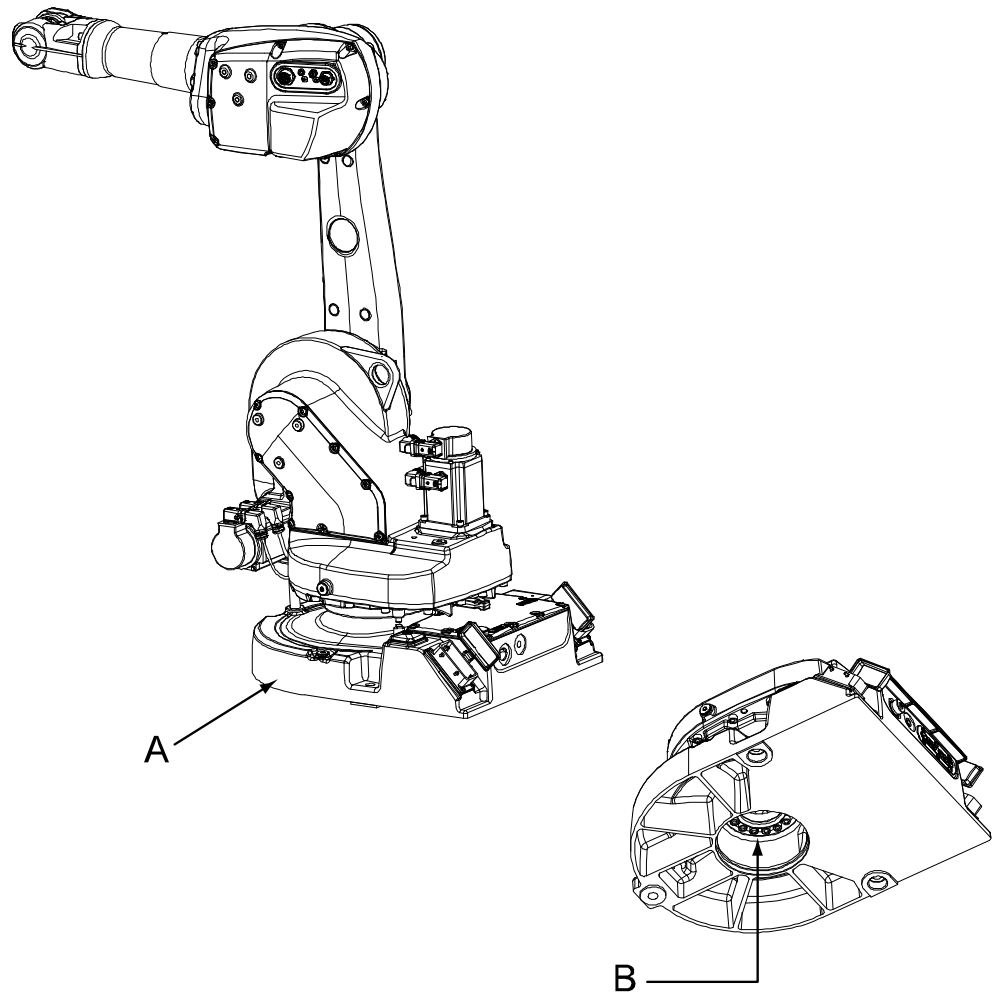

xx0500001453

A	Base
B	Attachment screws and washer, base-gearbox unit (VK-cover removed)

Required equipment

Equipment	Spare part no.	Art. no.	Note
Base, spare	For spare part number, see: <ul style="list-style-type: none"> <li><a href="#">Spare part lists on page 387.</a></li> </ul>		

Continues on next page

## 4 Repair

### 4.5.1 Replacement of base

Continued

Equipment	Spare part no.	Art. no.	Note
V-ring (sealing ring)	3HAB3732-21		Replace if damaged.
VK-cover	3HAA2166-26		
Lifting slings		-	
Locking liquid			Loctite 574 For sealing the base to the gearbox 1-2.
Grease		3HAB3537-1	For lubricating the V-ring.
Isopropanol			For cleaning the mating surfaces.
Standard toolkit		-	Content is defined in section <a href="#">Standard tools on page 383</a> .
Other tools and procedures may be required. See references to these procedures in the step-by-step instructions below.			These procedures include references to the tools required.

#### Deciding calibration routine

Decide which calibration routine to be used, based on the information in the table. Depending on which routine is chosen, action might be required prior to beginning the repair work of the robot, see the table.

	Action	Note
1	Decide which calibration routine to use for calibrating the robot. <ul style="list-style-type: none"> <li>Reference calibration. External cable packages (DressPack) and tools can stay fitted on the robot.</li> <li>Fine calibration. All external cable packages (DressPack) and tools must be removed from the robot.</li> </ul>	
	<p><b>If the robot is to be calibrated with reference calibration:</b></p> <p>Find previous reference values for the axis or create new reference values. These values are to be used after the repair procedure is completed, for calibration of the robot.</p> <p>If no previous reference values exist, and no new reference values can be created, then reference calibration is not possible.</p>	<p>Follow the instructions given in the reference calibration routine on the FlexPendant to create reference values.</p> <p>Creating new values requires possibility to move the robot.</p> <p>Read more about reference calibration for Axis Calibration in <a href="#">Reference calibration routine on page 350</a>.</p> <p>Read more about reference calibration for Pendulum Calibration in <i>Operating manual - Calibration Pendulum</i>.</p>
	<p><b>If the robot is to be calibrated with fine calibration:</b></p> <p>Remove all external cable packages (DressPack) and tools from the robot.</p>	



Continues on next page

**CAUTION**

Always cut the paint with a knife and grind the paint edge when disassembling parts. See [Cut the paint or surface on the robot before replacing parts on page 159](#).

**Removal, base**

The procedure below details how to remove the base from the robot.

	Action	Note
1	Decide which calibration routine to use, and take actions accordingly prior to beginning the repair procedure.	
2	 <b>DANGER</b> Turn off all: <ul style="list-style-type: none"> <li>• electric power supply</li> <li>• hydraulic pressure supply</li> <li>• air pressure supply</li> </ul> to the robot, before entering the robot working area.	
3	 <b>CAUTION</b> Always cut the paint with a knife and grind the paint edge when disassembling parts. See <a href="#">Cut the paint or surface on the robot before replacing parts on page 159</a> .	
4	Remove the cabling inside the base and pull it up to the gearbox unit.	The cable layout in the base is shown in the figure <a href="#">Illustration, cabling inside base on page 169</a> .
5	Remove the serial measurement unit.	Detailed in section <a href="#">Removing the serial measurement unit on page 247</a> .
6	Unfasten the base from the installation site by removing the attachment bolts from the foundation.	
7	 <b>CAUTION</b> The robot weighs . IRB 1600/IRB 1600ID: 250 kg IRB 1660ID: 260 kg All lifting accessories used must be sized accordingly!	
8	Fit the <i>lifting slings</i> to the robot, lift it and place it with the side of the lower arm downwards on a work bench. Be careful not to damage the motor connectors!	Art. no. is specified in <a href="#">Required equipment on page 239</a> .

Continues on next page

## 4 Repair



### 4.5.1 Replacement of base

Continued



	Action	Note
9	Remove the VK-cover from the base. <b>Tip!</b> Push out the cover from inside or drill a hole in the cover through which a tool can be inserted in order to bend out the cover.	
10	 <b>CAUTION</b> The robot base weighs 81 kg. All lifting accessories used must be sized accordingly!	
11	Secure the weight of the base and remove the gearbox/base attachment screws and washer.	Shown in the figure <a href="#">Location of base on page 239</a> .
12	Separate the base from the gearbox unit.	

### Refitting, base

The procedure below details how to refit the base to the robot.

	Action	Note
1	 <b>DANGER</b> Turn off all: <ul style="list-style-type: none"><li>• electric power supply</li><li>• hydraulic pressure supply</li><li>• air pressure supply</li></ul> to the robot, before entering the robot working area.	
2	Clean the joints that have been opened. See <a href="#">Cut the paint or surface on the robot before replacing parts on page 159</a>	
3	Place the robot with the side of the lower arm downwards on a workbench. Be careful not to damage the motor connectors.	
4	Clean the mating surfaces between the base and the gearbox unit with isopropanol.	
5	Check the V-ring on the gearbox unit. Lubricate with grease if needed. Replace it if damaged!	Spare part no. is specified in <a href="#">Required equipment on page 239</a> .
6	Lubricate the mating surface on the base with Loctite 574.	
7	 <b>CAUTION</b> The robot base weighs 81 kg. All lifting accessories used must be sized accordingly!	
8	Lift the base to mounting position.	

Continues on next page

	Action	Note
9	Secure the base to the gearbox unit with the <i>gearbox/base attachment screws and washer</i> .	Shown in the figure <i>Location of base on page 239</i> . 16 pcs, M10 x 40, tightening torque: 70 Nm.
10	Refit a new <i>VK-cover</i> to the base.	Spare part no. is specified in <i>Required equipment on page 239</i> .
11	 <b>CAUTION</b> The robot weighs . IRB 1600/IRB 1600ID: 250 kg IRB 1660ID: 260 kg All lifting accessories used must be sized accordingly!	
12	Turn the robot to stand upright.	
13	Secure the base to the foundation.	Attachment bolts and tightening torque are specified in section <i>Attachment bolts, specification on page 69</i> .
14	Pull down the cabling and refit it inside the base.	The cable layout inside the base is shown in the figure <i>Illustration, cabling inside base on page 169</i> .
15	Refit the serial measurement unit.	Detailed in section <i>Refitting the serial measurement unit on page 249</i> .
16	Seal and paint the joints that have been opened. See <i>Cut the paint or surface on the robot before replacing parts on page 159</i>   <b>Note</b> After all repair work, wipe the robot free from particles with spirit on a lint free cloth.	
17	Recalibrate the robot.	Pendulum Calibration is described in <i>Operating manual - Calibration Pendulum</i> , enclosed with the calibration tools. Axis Calibration is described in <i>Calibrating with Axis Calibration method on page 349</i> . General calibration information is included in section <i>Calibration on page 337</i> .
18	 <b>DANGER</b> Make sure all safety requirements are met when performing the first test run. These are further detailed in the section <i>First test run may cause injury or damage on page 28</i> .	

## 4 Repair

### 4.5.2 Replacing the serial measurement unit

#### 4.5.2 Replacing the serial measurement unit

##### Location of serial measurement unit

The serial measurement unit is located inside the base of the robot, as shown in the figure.

A more detailed view of the base may be found in the spare part view, see *Spare parts - Base, exploded view*.

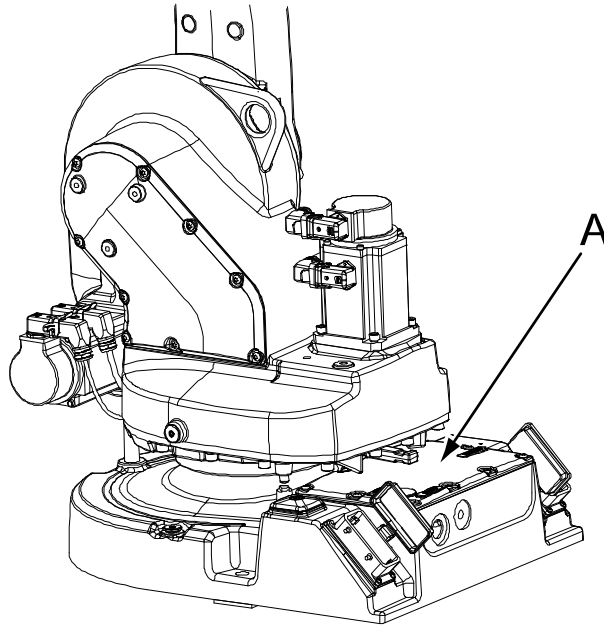

xx0500001390

A	Base cover, including gasket. Serial measurement unit is located beneath the cover.
---	---

*Continues on next page*



Serial measurement unit layout

The complete spare part of the serial measurement unit is shown in the figure.

DSQC 633A

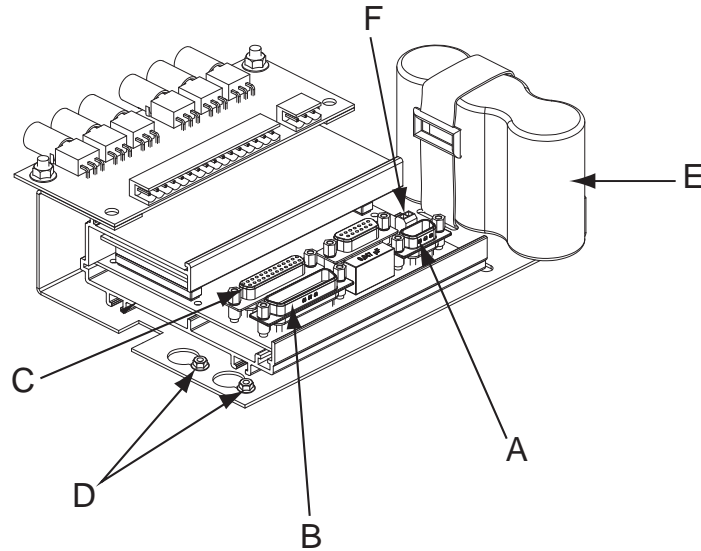

xx0500001391

A	Connector SMB
B	Connector SMB1-4
C	Connector SMB 3-6
D	Hexagon nuts (totally 4 pcs)
D	Hexagon nuts (totally 2 pcs). Only the outer nuts are used.
E	Battery pack (2-pole battery contact)
F	Battery cable connector

Continues on next page

## 4 Repair

### 4.5.2 Replacing the serial measurement unit

Continued

RMU 101

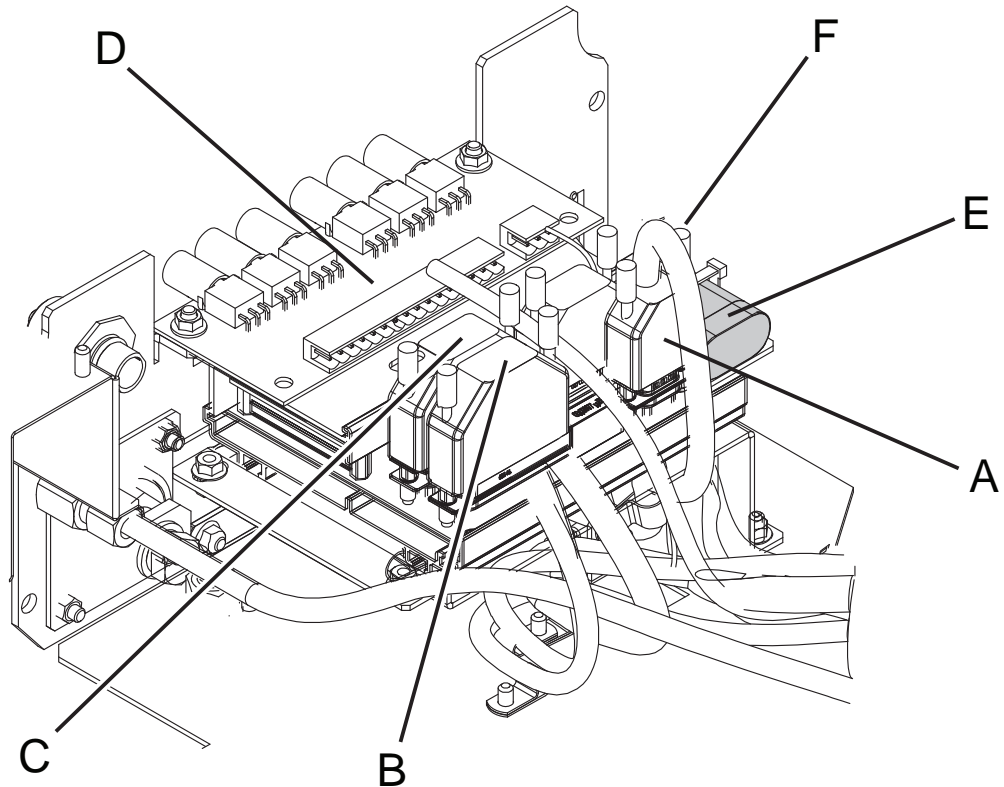

xx1300000331

A	Connector SMB
B	Connector SMB1-4
C	Connector SMB 3-6
D	BU unit
E	Battery pack (3-pole battery contact)
F	Battery cable connector

#### Required equipment



#### Note

There are different variants of SMB units and batteries. The variant with the 3-pole battery contact has longer lifetime for the battery.

It is important that the SMB unit uses the correct battery. Make sure to order the correct spare parts. Do not replace the battery contact!

Equipment	Art. no.	Note
Serial measurement unit	See <a href="#">Spare part lists on page 387</a> .	
Battery pack	See <a href="#">Spare part lists on page 387</a> .	

Continues on next page

Equipment	Art. no.	Note
Gasket, base cover	See <i>Spare part lists on page 387</i> .	
Centering piece	3HAC025815-001	Fitted to the push button unit in order to align it correctly. Replace if damaged.
Standard toolkit	-	Content is defined in section <i>Standard tools on page 383</i> .
Circuit diagram	-	See chapter <i>Circuit diagram on page 389</i> .



#### CAUTION

Always cut the paint with a knife and grind the paint edge when disassembling parts. See *Cut the paint or surface on the robot before replacing parts on page 159*.

### Removing the serial measurement unit

Use this procedure remove the serial measurement unit.

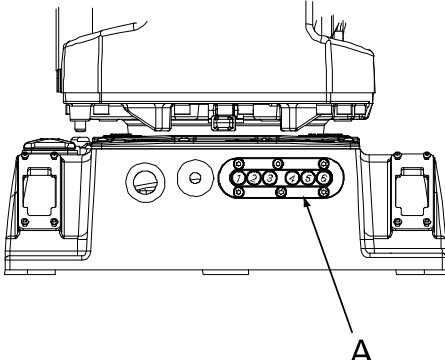

Action	Note
<p>1</p> <p><b>DANGER</b></p> <p>Turn off all:</p> <ul style="list-style-type: none"> <li>• electric power supply</li> <li>• hydraulic pressure supply</li> <li>• air pressure supply</li> </ul> <p>to the robot, before entering the robot working area.</p>	
<p>2</p> <p>Remove the push button guard from the base.</p>	<p>The push button guard must be removed to ensure a correct refitting of the push buttons.</p>  <p style="text-align: center;">xx0600002744</p> <p style="text-align: center;"><b>A Push button guard</b></p>

*Continues on next page*

## 4 Repair

### 4.5.2 Replacing the serial measurement unit

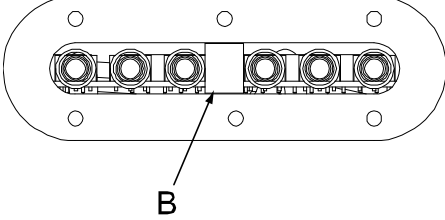

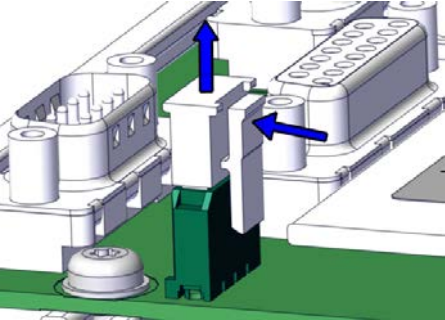
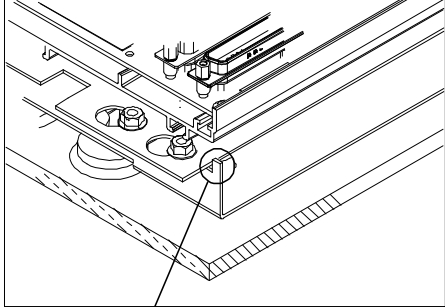
Continued

Action	Note
<p>3 Remove the centering piece from the push button unit.</p>	 <p>xx0600002776</p> <ul style="list-style-type: none"> <li>• B: Centering piece</li> </ul>
<p>4 Remove the <i>base cover</i>.</p> <p> <b>CAUTION</b></p> <p>Clean cover from metal residues before opening. Metal residues can cause shortage on the boards which can result in hazardous failures.</p>	<p>Shown in the figure <a href="#">Location of serial measurement unit on page 244</a>.</p>
<p>5 Disconnect the battery cable by pressing down the upper lip of the R2.G connector to release the lock while pulling the connector upwards.</p>	 <p>xx1700000993</p>
<p>6 Disconnect all remaining connectors to the serial measurement unit and push button units.</p>	
<p>7 Unscrew the <i>hexagon nuts</i> on the serial measurement unit a little and slide the SMB unit out. Do not remove the nuts!</p>	<p>Shown in the figure <a href="#">Serial measurement unit layout on page 245</a>.</p>
<p>8 Lift and pull the serial measurement unit backwards, over the lip (A), and lift it away.</p>	 <p>xx0500001455</p>

Continues on next page

## Refitting the serial measurement unit

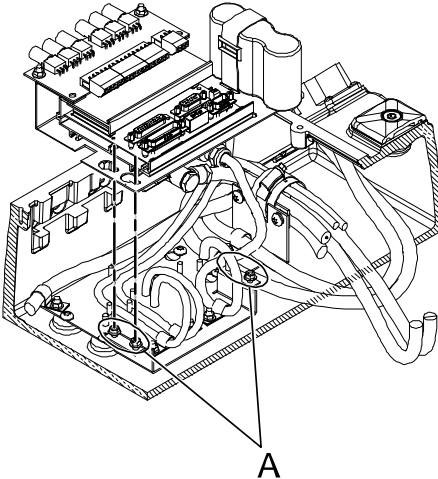
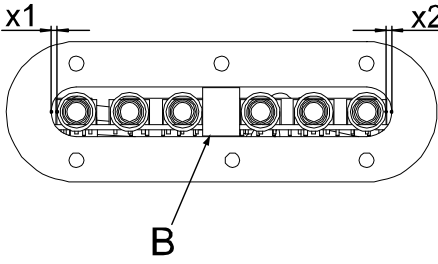
Use this procedure refit the serial measurement unit.

	Action	Note
1	Fit the serial measurement unit on to the four pins.	 <p>xx0500001392</p> <p>A Pins</p>
2	Slide the unit into position, within the lips, and secure with the four hexagon nuts.	Make sure the unit is positioned as straight as possible! The push buttons can otherwise get jammed.
3	Reconnect all the <i>connectors</i> . Make sure the lock on the battery cable connector R2.G snaps into place during refitting.	Shown in the figure <a href="#">Serial measurement unit layout on page 245</a> .
4	Refit the centering piece (B) to the push button unit in order to align it vertically. Also make sure that the unit is correctly aligned sideways: the measurements x1 and x2 in the figure to the right should not differ more than 1 mm from each other!	 <p>xx0600002777</p> <p>Art. no. for the centering piece is specified in <a href="#">Required equipment on page 246</a>.</p>
5	Check the <i>gasket</i> of the base cover. Replace it if damaged.	Spare part no. is specified in <a href="#">Required equipment on page 246</a> .
6	Refit the <i>base cover</i> .	Shown in the figure <a href="#">Location of serial measurement unit on page 244</a> .
7	 <p><b>WARNING</b></p> <p>Before continuing any service work, follow the safety procedure in section <a href="#">The brake release buttons may be jammed after service work on page 161</a>!</p>	
8	Refit the push button guard to the robot base.	

Continues on next page

## 4 Repair

---

### 4.5.2 Replacing the serial measurement unit

*Continued*

	Action	Note
9	Press the push buttons 1 to 6, one at a time, to make sure that the buttons are moving freely and do not stay in any locked position.	
10	Update the revolution counters!	Detailed in section <a href="#">Updating revolution counters on page 345</a> .

### 4.5.3 Replacing the push button unit

#### Location of push button unit

The push button unit for brake release is located inside the base of the robot.

A more detailed view of the component and its location is shown in the spare part view, see *Spare parts - Base, exploded view..*

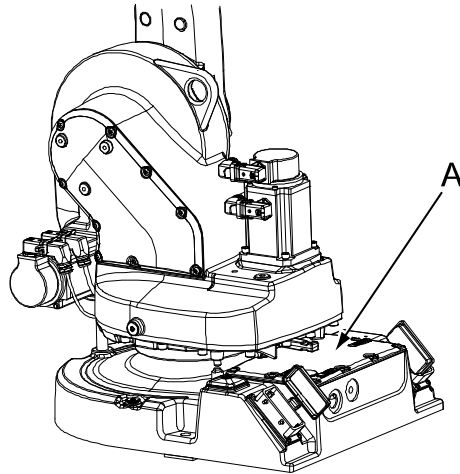

xx0500001390

A	Base cover, including gasket. Push button unit is located beneath the cover.
---	--

#### Push button unit on serial measurement unit

The push button unit is attached to the serial measurement unit as shown in the figure.

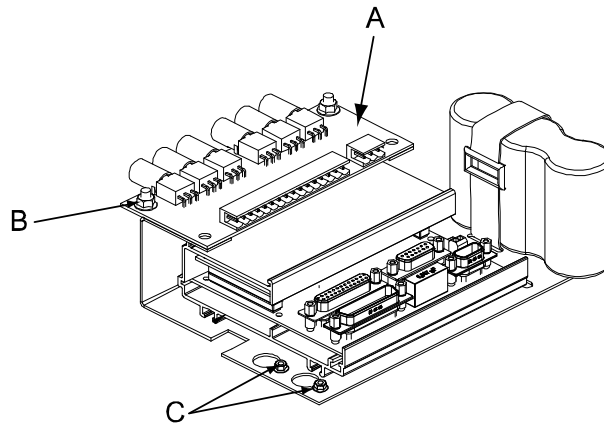

xx0500001394

A	Push button unit
B	Hexagon nuts (2 pcs)
C	Hexagon nuts, SMB unit (4 pcs). Only the outer ones are used.

*Continues on next page*

## 4 Repair

### 4.5.3 Replacing the push button unit

Continued

#### Required equipment

Equipment	Article number	Note
DSQC1054 Push button/Brake release unit	3HAC064944-001	
Gasket, base cover	3HAC022047-001	
Centering piece	3HAC025815-001	Fitted to the push button unit in order to align it correctly. Replace if damaged.
Standard toolkit		Content is defined in section <a href="#">Standard tools on page 383</a> .





#### CAUTION

Always cut the paint with a knife and grind the paint edge when disassembling parts. See [Cut the paint or surface on the robot before replacing parts on page 159](#).

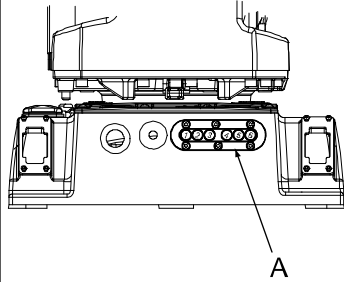

#### Removing the push button unit

Use this procedure to remove the push button unit.

Action	Note
<p>1</p>  <p><b>DANGER</b></p> <p>Turn off all:</p> <ul style="list-style-type: none"> <li>• electric power supply</li> <li>• hydraulic pressure supply</li> <li>• air pressure supply</li> </ul> <p>to the robot, before entering the robot working area.</p>	
<p>2</p>  <p><b>ELECTROSTATIC DISCHARGE (ESD)</b></p> <p>The unit is sensitive to ESD. Before handling the unit read the safety information in section <a href="#">The unit is sensitive to ESD on page 33</a></p>	
<p>3 Remove the push button guard from the base.</p>	<p>The push button guard must be removed to ensure a correct refitting of the push button unit.</p>  <p>xx0600002744</p> <p><b>A Push button guard</b></p>

Continues on next page

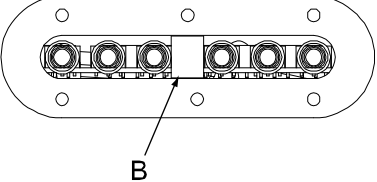

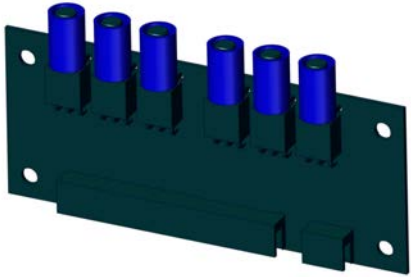
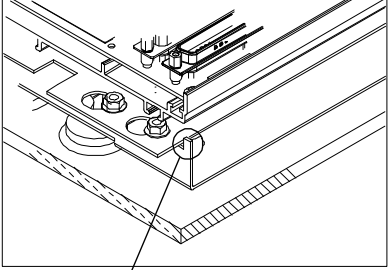
Action	Note
4 Remove the centering piece from the push button unit.	 <p>xx0600002776</p> <ul style="list-style-type: none"> <li>• B: Centering piece</li> </ul>
5 Remove the <i>base cover</i> from the robot.  <b>CAUTION</b> Clean cover from metal residues before opening. Metal residues can cause shortage on the boards which can result in hazardous failures.	Shown in the figure <a href="#">Location of push button unit on page 251</a> .
6 Take a picture or make notes of how the robot cabling is positioned in regard to the push button unit.	
7 Disconnect the connectors from the <i>brake release board</i> .	 <p>xx1800000171</p>
8 Unscrew the four <i>hexagon nuts on the SMB unit</i> enough to enable lifting the unit. Do not remove the nuts.	Shown in the figure <a href="#">Push button unit on serial measurement unit on page 251</a> .
9 Lift and pull the serial measurement unit backwards, over the lip (A), and lift it away.	 <p>xx0500001455</p>
10 Remove the two <i>hexagon nuts</i> from the push button unit.	Shown in the figure <a href="#">Push button unit on serial measurement unit on page 251</a> .
11 Remove the push button unit by lifting it up.	

Continues on next page



## 4 Repair

### 4.5.3 Replacing the push button unit



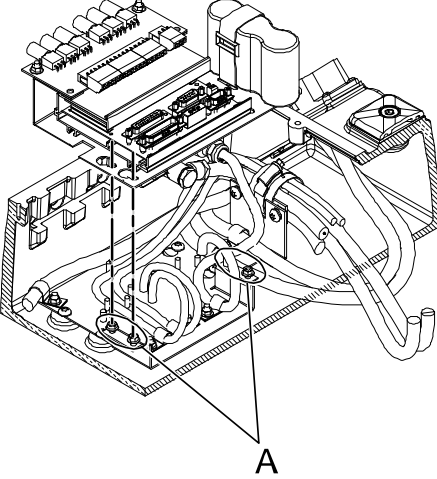

*Continued*

#### Refitting the push button unit

Use this procedure to refit the push button unit.

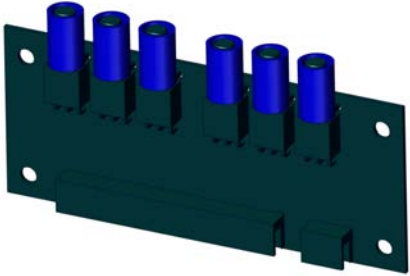
	Action	Note
1	 <p><b>DANGER</b></p> <p>Turn off all:</p> <ul style="list-style-type: none"> <li>• electric power supply</li> <li>• hydraulic pressure supply</li> <li>• air pressure supply</li> </ul> <p>to the robot, before entering the robot working area.</p>	
2	 <p><b>ELECTROSTATIC DISCHARGE (ESD)</b></p> <p>The unit is sensitive to ESD. Before handling the unit read the safety information in section <a href="#">The unit is sensitive to ESD on page 33</a></p>	
3	<p>Fit the new <i>push button unit</i> to the serial measurement unit.</p>	<p>Maximum tightening torque: 5 Nm. Spare part no. is specified in <a href="#">Required equipment on page 252</a>. Shown in the figure <a href="#">Push button unit on serial measurement unit on page 251</a>.</p>
4	<p>Fit the serial measurement unit on to the four pins.</p>	 <p>xx0500001392</p> <p>A Pins</p>
5	<p>Slide the unit into position, within the lips, and secure with the four hexagon nuts.</p>	<p>Make sure the unit is positioned as straight as possible! The push buttons can otherwise get jammed.</p>

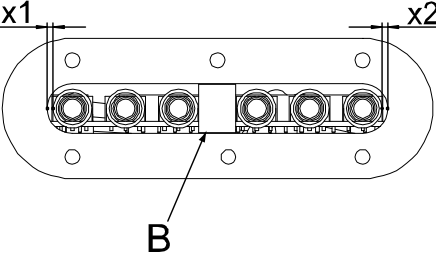

*Continues on next page*

Action	Note
<p>6 Reconnect all the connectors to the board. Be careful not to damage the sockets or pins. Make sure the connector and its locking arms are snapped down properly.</p>	 <p>xx1800000171</p>
<p>7 Verify that the robot cabling is positioned correctly, according to previously taken picture/notes.</p> <p> <b>WARNING</b></p> <p>Screened cables must not get in contact with the brake release board after installation. Eliminate all risks of contact between screened cables and the brake release board.</p>	
<p>8 Check the <i>gasket</i> of the base cover. Replace it if damaged.</p>	<p>Spare part no. is specified in <a href="#">Required equipment on page 252</a>.</p>
<p>9 Refit the base cover.</p>	<p>Shown in the figure <a href="#">Location of push button unit on page 251</a>.</p>
<p>10 Refit the centering piece (B) to the push button unit in order to align it vertically. Also make sure that the unit is correctly aligned sideways: the measurements x1 and x2 in the figure to the right should not differ more than 1 mm from each other!</p>	 <p>xx0600002777</p>
<p>11  <b>WARNING</b></p> <p>Before continuing any service work, follow the safety procedure in section <a href="#">The brake release buttons may be jammed after service work on page 161</a>!</p>	

## 4 Repair

### 4.5.3 Replacing the push button unit

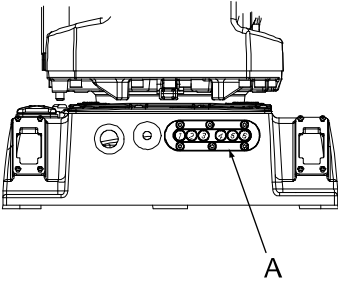
*Continued*

Action	Note
12 Refit the push button guard to the robot base.	 <p>xx0600002744</p> <p><b>A</b> Push button guard</p>
13 Press the push buttons 1 to 6, one at a time, to make sure that the buttons are moving freely and do not stay in any locked position.	
14 Update the revolution counters!	Detailed in section <a href="#">Updating revolution counters on page 345</a> .
15  <b>DANGER</b> Make sure all safety requirements are met when performing the first test run. These are further detailed in section <a href="#">First test run may cause injury or damage on page 28</a> .	

## 4.6 Motors

### 4.6.1 Replacement of motor, axis 1

#### Location of motor

The axis 1 motor is located on the frame, as shown in the figure.

A more detailed view of the motor and its position may be found in the spare part view, see *Spare parts - Frame, exploded view*.

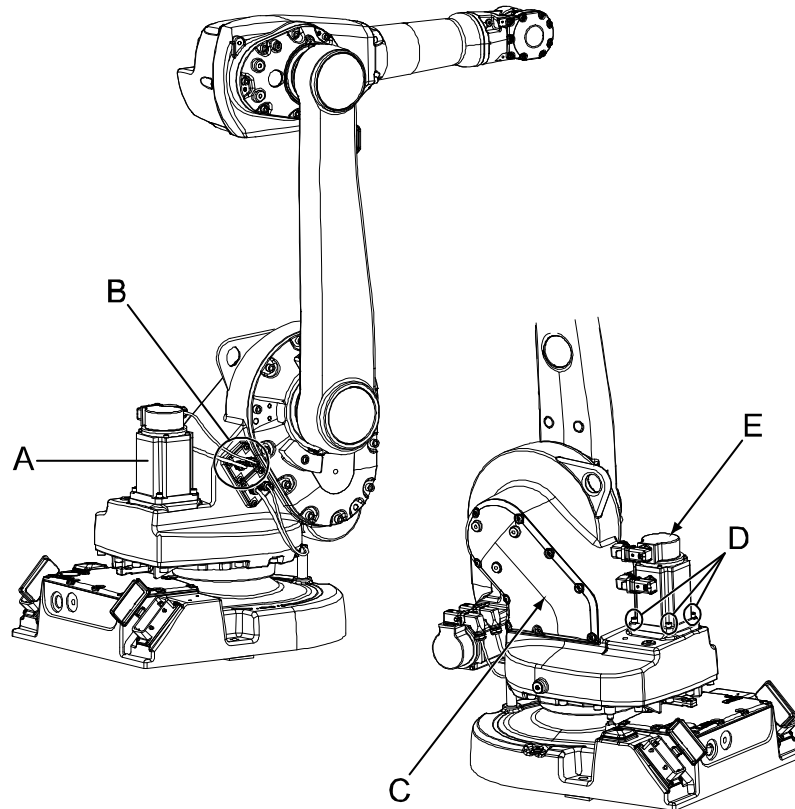

xx0400001256

A	Motor, axis 1
B	Connector plate for motor cabling
C	Cover, frame
D	Attachment screws, motor (4 pcs)
E	Motor cover

#### Required equipment

Equipment	Art. no.	Note
Standard, Rot. ac motor incl. pinion	For spare part number, see: <ul style="list-style-type: none"> <li><a href="#">Spare part lists on page 387</a></li> </ul>	Cable harness, motor axes 1-2 must be ordered separately.

*Continues on next page*

## 4 Repair

### 4.6.1 Replacement of motor, axis 1

Continued

Equipment	Art. no.	Note
Cable harness, motor axes 1-2	For spare part number, see: <ul style="list-style-type: none"> <li>• <a href="#">Spare part lists on page 387</a></li> </ul>	
O-ring	21522012-428	O-ring, motor. Replace if damaged.
Gasket, gearbox axis 1-2	For spare part number, see: <ul style="list-style-type: none"> <li>• <a href="#">Spare part lists on page 387</a></li> </ul>	Replace if damaged.
Power supply	-	24 VDC, max 1.5 A For releasing the brakes.
Isopropanol	-	Used to clean mating surfaces.
Locking liquid	-	Loctite 574
Rotation tool, motor	3HAC022266-003	
Standard toolkit	-	Content is defined in section <a href="#">Standard tools on page 383</a> .
Circuit diagram	-	See <a href="#">Circuit diagram on page 389</a> .



#### CAUTION

Always cut the paint with a knife and grind the paint edge when disassembling parts. See [Cut the paint or surface on the robot before replacing parts on page 159](#).

### Deciding calibration routine

Decide which calibration routine to be used, based on the information in the table. Depending on which routine is chosen, action might be required prior to beginning the repair work of the robot, see the table.

	Action	Note
1	Decide which calibration routine to use for calibrating the robot. <ul style="list-style-type: none"> <li>• Reference calibration. External cable packages (DressPack) and tools can stay fitted on the robot.</li> <li>• Fine calibration. All external cable packages (DressPack) and tools must be removed from the robot.</li> </ul>	
	<p><b>If the robot is to be calibrated with reference calibration:</b></p> <p>Find previous reference values for the axis or create new reference values. These values are to be used after the repair procedure is completed, for calibration of the robot.</p> <p>If no previous reference values exist, and no new reference values can be created, then reference calibration is not possible.</p>	<p>Follow the instructions given in the reference calibration routine on the FlexPendant to create reference values.</p> <p>Creating new values requires possibility to move the robot.</p> <p>Read more about reference calibration for Axis Calibration in <a href="#">Reference calibration routine on page 350</a>.</p> <p>Read more about reference calibration for Pendulum Calibration in <i>Operating manual - Calibration Pendulum</i>.</p>

Continues on next page

Action	Note
<p><b>If the robot is to be calibrated with fine calibration:</b></p> <p>Remove all external cable packages (DressPack) and tools from the robot.</p>	

### Removing the motor axis 1

Use this procedure to remove the motor, axis 1.

	Action	Note
1	Decide which calibration routine to use, and take actions accordingly prior to beginning the repair procedure.	
2	 <p><b>DANGER</b></p> <p>Turn off all:</p> <ul style="list-style-type: none"> <li>• electric power supply</li> <li>• hydraulic pressure supply</li> <li>• air pressure supply</li> </ul> <p>to the robot, before entering the robot working area.</p>	
3	Remove the <i>cover, frame</i> .	Shown in the figure <a href="#">Location of motor on page 257</a> .
4	Disconnect the connectors for the motor.	
5	Loosen the <i>connector plate</i> from the frame.	
6	Pull out the motor cabling carefully.	
7	In order to release the brakes, connect the 24 VDC power supply to the motor.	<p>Connect to connector R3.MP1:</p> <ul style="list-style-type: none"> <li>• +: pin 7</li> <li>• -: pin 8</li> </ul>
8	Unscrew the <i>attachment screws</i> securing the motor.	Shown in the figure <a href="#">Location of motor on page 257</a> .
9	Remove the motor by gently lifting it straight up, making sure the motor pinion is not damaged against the gear.	
10	Disconnect the brake release voltage from the motor connector.	

### Refitting the motor axis 1

Use this procedure to refit the motor, axis 1.

	Action	Note
1	 <p><b>DANGER</b></p> <p>Turn off all:</p> <ul style="list-style-type: none"> <li>• electric power supply</li> <li>• hydraulic pressure supply</li> <li>• air pressure supply</li> </ul> <p>to the robot, before entering the robot working area.</p>	

Continues on next page

## 4 Repair

### 4.6.1 Replacement of motor, axis 1

Continued

	Action	Note
2	 <b>Note</b> It is important that the gearbox and the mating motor pinion are provided by the same sub-supplier, make sure to order the correct spare part! To determine the correct spare part, see <i>Compatible gearboxes and motors in Product manual, spare parts - IRB 1600/1660</i> .	
3	Clean the mating surfaces.	
4	Replace the <i>o-ring</i> if damaged. <ol style="list-style-type: none"> <li>1 Apply enough Loctite 574 to the motor groove.</li> <li>2 Refit the <i>o-ring</i>. Make sure the <i>o-ring</i> on the circumference of the motor is seated properly.</li> </ol>	Spare part number is specified in <a href="#">Required equipment on page 257</a> .
5	Remove the <i>motor cover</i> from top of the motor.	Shown in the figure <a href="#">Location of motor on page 257</a> .
6	In order to release the brakes, connect the 24 VDC power supply to the motor.	Connect to connector R3.MP1: <ul style="list-style-type: none"> <li>• +: pin 7</li> <li>• -: pin 8</li> </ul>
7	Fit the <i>rotation tool</i> to the end of the motor shaft.	Article number is specified in <a href="#">Required equipment on page 257</a> .
8	Fit the motor, making sure the motor pinion is properly mated to the gear of gearbox, axis 1. Use the <i>rotation tool</i> to rotate the motor pinion, when mating it to the gear.	
9	Secure the motor with four attachment screws and washers, but do not tighten yet.	4 pcs, M8 x 25.
10	Adjust the motor in relation to the gear in the gearbox: <ul style="list-style-type: none"> <li>• use the rotation tool to wiggle the motor shaft back and forth to feel the play. Tap with a plastic mallet.</li> <li>• position the motor pinion at at least two other positions by turning axis 1 manually and check the gear play again.</li> </ul>	There should be a barely noticeable gear play.
11	Tighten the motor attachment screws.	Tightening torque: 35 Nm.
12	Disconnect the brake release voltage.	
13	Refit the <i>motor cover</i> to top of the motor.	Shown in the figure <a href="#">Location of motor on page 257</a> .
14	Insert the motor cabling through the frame and secure the <i>connector plate</i> with attachment screws.	4 pcs.
15	Connect all the connectors.	The cable layout is shown in the figure <a href="#">Illustration, cabling inside frame on page 168</a> .
16	Refit the cover, frame. Replace the <i>gasket</i> , if damaged.	

Continues on next page



	Action	Note
17	Recalibrate the robot!	<p>Pendulum Calibration is described in <i>Operating manual - Calibration Pendulum</i>, enclosed with the calibration tools.</p> <p>Axis Calibration is described in <a href="#">Calibrating with Axis Calibration method on page 349</a>.</p> <p>General calibration information is included in section <a href="#">Calibration on page 337</a>.</p>
18	 <p><b>DANGER</b></p> <p>Make sure all safety requirements are met when performing the first test run. These are further detailed in the section <a href="#">First test run may cause injury or damage on page 28</a>.</p>	

## 4 Repair

### 4.6.2 Replacement of motor, axis 2

#### 4.6.2 Replacement of motor, axis 2

##### Location of motor axis 2

The motor axis 2 is located on the front of the robot as shown in the figure.

A more detailed view of the motor and its position may be found in the spare part view, see *Spare parts - Frame, exploded view*.

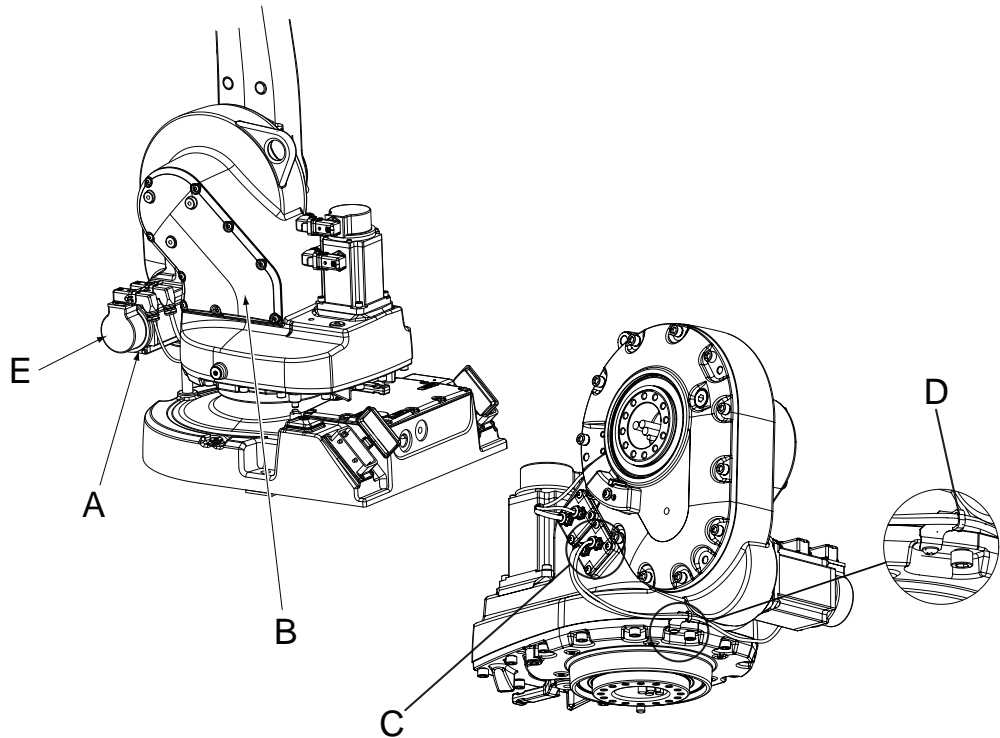

xx0400001257

A	Motor, axis 2
B	Cover, frame
C	Connector plate for motor cabling
D	Bracket and cable tie
E	Motor cover

##### Required equipment

Equipment, etc.	Art. no.	Note
Rot. ac motor with pinion	For spare part number, see: <ul style="list-style-type: none"><li><a href="#">Spare part lists on page 387</a></li></ul>	
Cable harness, motor axes 1-2	For spare part number, see: <ul style="list-style-type: none"><li><a href="#">Spare part lists on page 387</a></li></ul>	

*Continues on next page*

Equipment, etc.	Art. no.	Note
O-ring	21522012-428	Must be replaced when replacing motor.
Gasket, gearbox axis 1-2	For spare part number, see: <ul style="list-style-type: none"> <li><a href="#">Spare part lists on page 387</a></li> </ul>	Replace if damaged.
Locking liquid		Loctite 574
Isopropanol	-	For cleaning mating surfaces.
Standard toolkit	-	Content is defined in section <a href="#">Standard tools on page 383</a> .
Rotation tool, motor	3HAC022266-003	For adjusting the gear play, motor/pinion
Power supply	-	24 VDC, 1.5 A. For releasing the brakes.
Other tools and procedures may be required. See references to these procedures in the step-by-step instructions below.		These procedures include references to the tools required.
Circuit diagram	-	See chapter <a href="#">Circuit diagram on page 389</a> .

**CAUTION**

Always cut the paint with a knife and grind the paint edge when disassembling parts. See [Cut the paint or surface on the robot before replacing parts on page 159](#).

**Deciding calibration routine**

Decide which calibration routine to be used, based on the information in the table. Depending on which routine is chosen, action might be required prior to beginning the repair work of the robot, see the table.

Action	Note
1 Decide which calibration routine to use for calibrating the robot. <ul style="list-style-type: none"> <li>Reference calibration. External cable packages (DressPack) and tools can stay fitted on the robot.</li> <li>Fine calibration. All external cable packages (DressPack) and tools must be removed from the robot.</li> </ul>	
<p><b>If the robot is to be calibrated with reference calibration:</b></p> <p>Find previous reference values for the axis or create new reference values. These values are to be used after the repair procedure is completed, for calibration of the robot.</p> <p>If no previous reference values exist, and no new reference values can be created, then reference calibration is not possible.</p>	<p>Follow the instructions given in the reference calibration routine on the FlexPendant to create reference values.</p> <p>Creating new values requires possibility to move the robot.</p> <p>Read more about reference calibration for Axis Calibration in <a href="#">Reference calibration routine on page 350</a>.</p> <p>Read more about reference calibration for Pendulum Calibration in <i>Operating manual - Calibration Pendulum</i>.</p>

Continues on next page

## 4 Repair



### 4.6.2 Replacement of motor, axis 2

Continued

Action	Note
If the robot is to be calibrated with fine calibration: Remove all external cable packages (DressPack) and tools from the robot.	

#### Removal, motor axis 2

The procedure below details how to remove the axis 2 motor.

	Action	Note
1	Decide which calibration routine to use, and take actions accordingly prior to beginning the repair procedure.	
2	 <b>DANGER</b> Turn off all: <ul style="list-style-type: none"><li>• electric power supply</li><li>• hydraulic pressure supply</li><li>• air pressure supply</li></ul> to the robot, before entering the robot working area.	
3	 <b>CAUTION</b> Always cut the paint with a knife and grind the paint edge when disassembling parts. See <a href="#">Cut the paint or surface on the robot before replacing parts on page 159</a> .	
4	Remove the cover, frame.	Shown in the figure <a href="#">Location of motor axis 2 on page 262</a> .
5	Disconnect the motor connectors inside the frame.	Connectors: <ul style="list-style-type: none"><li>• R3.MP2</li><li>• R3.FB2</li></ul>
6	Cut any cable ties and remove any brackets or clamps securing the cables.	
7	Remove the <i>connector plate</i> by removing its attachment screws, and pull the cables out from the frame.	Shown in the figure <a href="#">Location of motor axis 2 on page 262</a> .
8	 <b>DANGER</b> Secure the weight of the lower arm properly before releasing the brakes of motor, axis 2! When releasing the holding brakes of the motor, the lower arm will be movable and may fall down!	
9	In order to release the brakes, connect the 24 VDC power supply to the motor.	Connect to connector R3.MP2 <ul style="list-style-type: none"><li>• +: pin 7</li><li>• -: pin 8</li></ul>

Continues on next page

	Action	Note
10	 <b>WARNING</b> Oil will be running out of the motor attachment hole when removing the motor! It may also be hot! Take any necessary measures to collect the oil.	
11	Remove the motor by unscrewing its four <i>attachment screws</i> and plain washers.	Shown in the figure <a href="#">Location of motor axis 2 on page 262</a> .
12	Remove the motor by gently pulling it out, making sure the motor pinion does not get damaged while moving it away from the gear.	
13	Disconnect the brake release voltage.	
14	Remove any remaining oil from the gearbox by siphoning it off.	

### Refitting, motor axis 2

The procedure below details how to refit the axis 2 motor.

	Action	Note
1	 <b>Note</b> It is important that the gearbox and the mating motor pinion are provided by the same sub-supplier, make sure to order the correct spare part! To determine the correct spare part, see <i>Compatible gearboxes and motors in Product manual, spare parts - IRB 1600/1660</i> .	
2	Clean the joints that have been opened. See <a href="#">Cut the paint or surface on the robot before replacing parts on page 159</a>	
3	Make sure the mating surfaces on the motor and the gearbox are clean and free from burrs. If necessary, clean the surfaces with isopropanol.	
4	Replace the <i>o-ring</i> if damaged. <ol style="list-style-type: none"> <li>1 Apply enough Loctite 574 to the motor groove.</li> <li>2 Refit the <i>o-ring</i>. Make sure the <i>o-ring</i> on the circumference of the motor is seated properly.</li> </ol>	Art. no. is specified in section <a href="#">Required equipment on page 262</a> .
5	In order to release the brakes, connect the 24 VDC power supply to the motor.	Connect to connector R3.MP2: <ul style="list-style-type: none"> <li>• +: pin 7</li> <li>• -: pin 8</li> </ul>
6	Remove the <i>motor cover</i> from top of the motor.	Shown in the figure <a href="#">Location of motor axis 2 on page 262</a> .
7	Fit the <i>rotation tool</i> to the end of the motor shaft.	Art. no. is specified in section <a href="#">Required equipment on page 262</a> .
8	Fit the motor, making sure the motor pinion is properly mated to gearbox 2. Use the rotation tool to rotate the motor pinion, when mating it to the gear.	Make sure the motor is turned the right way, i.e. connections upwards. Make sure the motor pinion does not get damaged!

Continues on next page

## 4 Repair

### 4.6.2 Replacement of motor, axis 2

Continued

	Action	Note
9	Secure the motor with four attachment screws and plain washers, but do not tighten yet.	4 pcs, M8 x 25. Tightening torque: approx 2 Nm.
10	Adjust the motor in relation to the gear in the gearbox. Use the rotation tool to wiggle the motor shaft back and forth to feel the play. Tap with a plastic mallet.	There should be a barely noticeable gear play.
11	Refit the motor cover to the top of the motor. Be careful not to damage the cables!	
12	Tighten the motor attachment screws.	Tightening torque: 35 Nm
13	Disconnect the brake release voltage.	
14	Refit the <i>connector plate</i> with its attachment screws.	Shown in the figure <a href="#">Location of motor axis 2 on page 262</a> .
15	Reconnect the motor connectors inside the frame.	Cable layout is shown in the figure <a href="#">Illustration, cabling inside frame on page 168</a> .
16	Refit all cable ties, and the <i>bracket</i> underneath the frame.	Shown in the figure <a href="#">Location of motor axis 2 on page 262</a> .
17	Refit the <i>cover, frame</i> . Replace the gasket, if damaged.	Shown in the figure <a href="#">Location of motor axis 2 on page 262</a> . Art. no. for the gasket is specified in section <a href="#">Required equipment on page 262</a> .
18	Perform a leak-down test.	Detailed in section <a href="#">Performing a leak-down test on page 154</a> .
19	Refill the gearbox with oil.	See, <a href="#">Technical reference manual - Lubrication in gearboxes</a> .
20	Seal and paint the joints that have been opened. See <a href="#">Cut the paint or surface on the robot before replacing parts on page 159</a>   <b>Note</b> After all repair work, wipe the robot free from particles with spirit on a lint free cloth.	
21	Recalibrate the robot!	Pendulum Calibration is described in <a href="#">Operating manual - Calibration Pendulum</a> , enclosed with the calibration tools. Axis Calibration is described in <a href="#">Calibrating with Axis Calibration method on page 349</a> . General calibration information is included in section <a href="#">Calibration on page 337</a> .

Continues on next page

	Action	Note
22	 <b>DANGER</b> Make sure all safety requirements are met when performing the first test run. These are further detailed in the section <i>First test run may cause injury or damage on page 28.</i>	

## 4 Repair

### 4.6.3 Replacement of motor, axis 3, IRB 1600

### 4.6.3 Replacement of motor, axis 3, IRB 1600

#### Location of motor

The motor of axis 3 is located inside the upper arm housing, as shown in the figure below.

A more detailed view of the motor and its position may be found in the spare part view, *Spare parts - Upper arm, exploded view*.

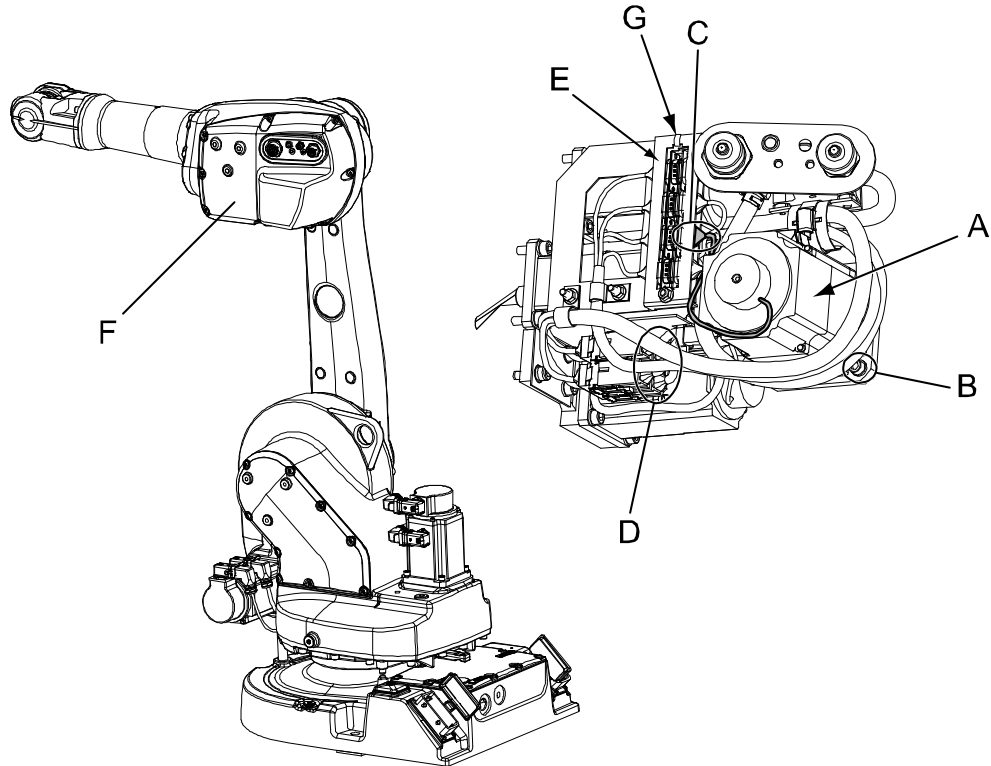

xx0400001258

A	Motor, axis 3
B	Attachment screws and washers of the motor (4 pcs)
C	Signal connector R3.FB3
D	Power connector R3.MP3
E	Connector holder
F	Upper arm housing cover
G	Cable tie

#### Required equipment

Equipment	Art. no.	Note
Rot. ac motor incl pinion	For spare part number, see: <ul style="list-style-type: none"><li><a href="#">Spare part lists on page 387</a></li></ul>	
O-ring	21522012-426	Replace if damaged.

*Continues on next page*



Equipment	Art. no.	Note
Gasket, upper arm cover	3HAC022049-001	Replace if damaged.
Gasket, customer connections	3HAC022050-001	Replace if damaged.
Isopropanol	-	Used for cleaning the mating surfaces.
Grease	3HAB3537-1	Used for lubricating the o-ring.
Rotation tool, motor	3HAC022266-003	For adjusting the gear play.
Other tools and procedures may be required. See references to these procedures in the step-by-step instructions below.		These procedures include references to the tools required.
Circuit diagram		See chapter <a href="#">Circuit diagram on page 389</a> .

**CAUTION**

Always cut the paint with a knife and grind the paint edge when disassembling parts. See [Cut the paint or surface on the robot before replacing parts on page 159](#).

**Deciding calibration routine**

Decide which calibration routine to be used, based on the information in the table. Depending on which routine is chosen, action might be required prior to beginning the repair work of the robot, see the table.

	Action	Note
1	<p>Decide which calibration routine to use for calibrating the robot.</p> <ul style="list-style-type: none"> <li>Reference calibration. External cable packages (DressPack) and tools can stay fitted on the robot.</li> <li>Fine calibration. All external cable packages (DressPack) and tools must be removed from the robot.</li> </ul>	
	<p><b>If the robot is to be calibrated with reference calibration:</b></p> <p>Find previous reference values for the axis or create new reference values. These values are to be used after the repair procedure is completed, for calibration of the robot.</p> <p>If no previous reference values exist, and no new reference values can be created, then reference calibration is not possible.</p>	<p>Follow the instructions given in the reference calibration routine on the FlexPendant to create reference values.</p> <p>Creating new values requires possibility to move the robot.</p> <p>Read more about reference calibration for Axis Calibration in <a href="#">Reference calibration routine on page 350</a>.</p> <p>Read more about reference calibration for Pendulum Calibration in <a href="#">Operating manual - Calibration Pendulum</a>.</p>
	<p><b>If the robot is to be calibrated with fine calibration:</b></p> <p>Remove all external cable packages (DressPack) and tools from the robot.</p>	

Continues on next page



## 4 Repair

### 4.6.3 Replacement of motor, axis 3, IRB 1600

Continued

#### Removal, motor axis 3

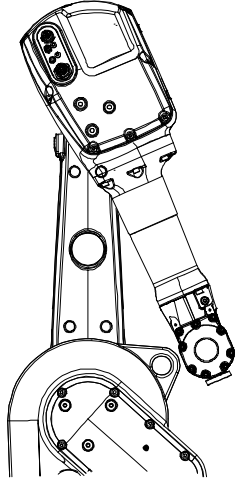
The procedure below details how to remove the axis 3 motor.

	Action	Note
1	Decide which calibration routine to use, and take actions accordingly prior to beginning the repair procedure.	
2	 <b>DANGER</b> Turn off all: <ul style="list-style-type: none"> <li>• electric power supply</li> <li>• hydraulic pressure supply</li> <li>• air pressure supply</li> </ul> to the robot, before entering the robot working area.	
3	Remove any additional mechanical stops from axis 3.	
4	Move: <ul style="list-style-type: none"> <li>• axis 2 to calibration position</li> <li>• upper arm backwards against the mechanical stop.</li> </ul> This position enables removal of the motor without draining of the gearbox, axis 3.	 xx0500001447
5	Remove the <i>upper arm housing cover</i> .	Shown in the figure <a href="#">Location of motor on page 268</a> .
6	Disconnect the motor connectors R3.MP3 and R3.FB3.	Shown in the figure <a href="#">Location of motor on page 268</a> .
7	 <b>DANGER</b> Secure the weight of the upper arm properly before releasing the brakes of motor, axis 3. When releasing the holding brakes of the motor, the upper arm will be movable and may fall down!	
8	In order to release the brakes, connect the 24 VDC power supply to the motor.	Connect to connector R3.MP3: <ul style="list-style-type: none"> <li>• +: pin 7</li> <li>• -: pin 8</li> </ul>
9	Remove the motor, axis 3, by unscrewing its attachment screws and washers. Lift the motor gently straight out, making sure the motor pinion is not damaged.	
10	Disconnect the brake release voltage.	

Continues on next page

## Refitting, motor axis 3

The procedure below details how to refit the axis 3 motor.

	Action	Note
1	 <b>Note</b> It is important that the gearbox and the mating motor pinion are provided by the same sub-supplier, make sure to order the correct spare part! To determine the correct spare part, see <i>Compatible gearboxes and motors</i> in <i>Product manual, spare parts - IRB 1600/1660</i> .	
2	Clean the mating surfaces inside the upper arm housing and on the motor with isopropanol.	
3	Make sure the <i>o-ring</i> on the circumference of the motor is seated properly. Lightly lubricate it with grease.	Replace the o-ring if damaged. Art .no. is specified in section <a href="#">Required equipment on page 268</a> .
4	In order to release the brakes, connect the 24 VDC power supply to the motor.	Connect to connector R3.MP3: <ul style="list-style-type: none"> <li>• +: pin 7</li> <li>• -: pin 8</li> </ul>
5	Fit the motor to the upper arm housing, making sure the motor pinion is properly mated to the gear of axis 3.	
6	Fit the <i>attachment screws and washers</i> but do not tighten them yet.	4 pcs, M6 x 20. Shown in the figure <a href="#">Location of motor on page 268</a> .
7	Fit the <i>rotation tool</i> to the end of the motor shaft.	Art. no. is specified in <a href="#">Required equipment on page 268</a> .
8	Adjust the motor in relation to the gear. Use the rotation tool to wiggle the motor shaft back and forth to feel the play.	There should be a barely noticeable gear play.
9	Tighten the motor attachment screws.	Tightening torque: 10 Nm.
10	Disconnect the brake release voltage.	
11	Reconnect the motor connectors, run and secure the cabling correctly inside the upper arm housing.	Cable layout is shown in the figure <a href="#">Illustration, cabling inside upper arm housing on page 166</a> .
12	Refit the <i>cover, upper arm housing</i> . Check both the <i>gaskets</i> and replace, if damaged.	Shown in the figure <a href="#">Location of motor on page 268</a> . Art. no. is specified in section <a href="#">Required equipment on page 268</a> .
13	Refit any additional mechanical stops.	Detailed in section <a href="#">Installation of additional mechanical stops on axis 3 on page 109</a> .

Continues on next page

## 4 Repair

### 4.6.3 Replacement of motor, axis 3, IRB 1600

*Continued*

	Action	Note
14	Recalibrate the robot!	<p>Pendulum Calibration is described in <i>Operating manual - Calibration Pendulum</i>, enclosed with the calibration tools.</p> <p>Axis Calibration is described in <a href="#">Calibrating with Axis Calibration method on page 349</a>.</p> <p>General calibration information is included in section <a href="#">Calibration on page 337</a>.</p>
15	 <b>DANGER</b> Make sure all safety requirements are met when performing the first test run. These are further detailed in the section <a href="#">First test run may cause injury or damage on page 28</a> .	

## 4.6.4 Replacement of motor, axis 3, 1600ID/1660ID

**Note**

After replacement of motors/motor in a manipulator, recalibration is required.

**Location of motor**

The motor of axis 3 is located inside the upper arm housing, as shown in the figure below.

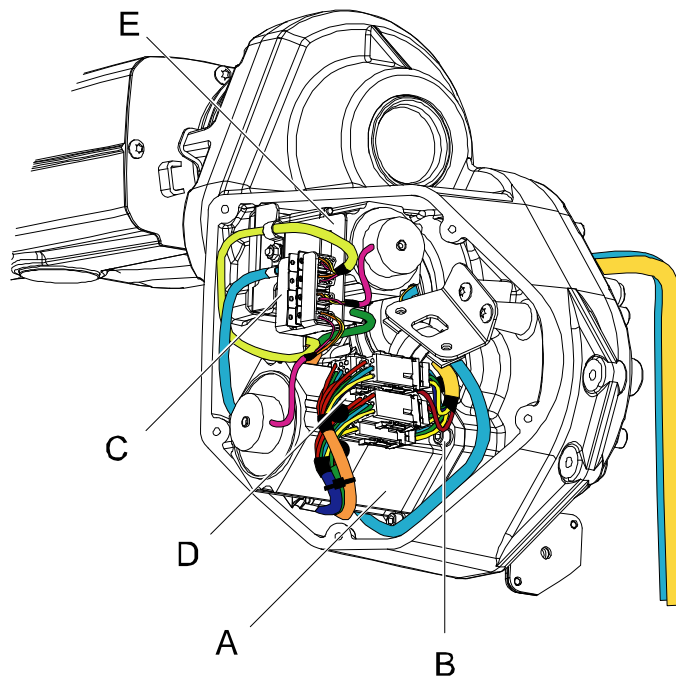

xx070000008

A	Motor, axis 3
B	Attachment screws and washers of the motor (4 pcs)
C	Signal connector R3.FB3
D	Power connector R3.MP3
E	Connector holder

**Required equipment**

Equipment	Art.no.	Note
Rot. ac motor incl pinion	For spare part number, see: • <a href="#">Spare part lists on page 387.</a>	
O-ring	3HAB3772-100	
Isopropanol		Used for cleaning the mating surfaces.
Grease		

*Continues on next page*

## 4 Repair

### 4.6.4 Replacement of motor, axis 3, 1600ID/1660ID

Continued

Equipment	Art.no.	Note
Standard tools		<a href="#">Standard tools on page 383</a>
Circuit diagram		
Pendulum Calibration tool		



#### CAUTION

Always cut the paint with a knife and grind the paint edge when disassembling parts. See [Cut the paint or surface on the robot before replacing parts on page 159](#).

#### Deciding calibration routine

Decide which calibration routine to be used, based on the information in the table. Depending on which routine is chosen, action might be required prior to beginning the repair work of the robot, see the table.

	Action	Note
1	Decide which calibration routine to use for calibrating the robot. <ul style="list-style-type: none"> <li>Reference calibration. External cable packages (DressPack) and tools can stay fitted on the robot.</li> <li>Fine calibration. All external cable packages (DressPack) and tools must be removed from the robot.</li> </ul>	
	<b>If the robot is to be calibrated with reference calibration:</b> Find previous reference values for the axis or create new reference values. These values are to be used after the repair procedure is completed, for calibration of the robot.  If no previous reference values exist, and no new reference values can be created, then reference calibration is not possible.	Follow the instructions given in the reference calibration routine on the FlexPendant to create reference values.  Creating new values requires possibility to move the robot.  Read more about reference calibration for Axis Calibration in <a href="#">Reference calibration routine on page 350</a> .  Read more about reference calibration for Pendulum Calibration in <i>Operating manual - Calibration Pendulum</i> .
	<b>If the robot is to be calibrated with fine calibration:</b> Remove all external cable packages (DressPack) and tools from the robot.	

#### Removal, motor axis 3

	Action	Note
1	Decide which calibration routine to use, and take actions accordingly prior to beginning the repair procedure.	

Continues on next page

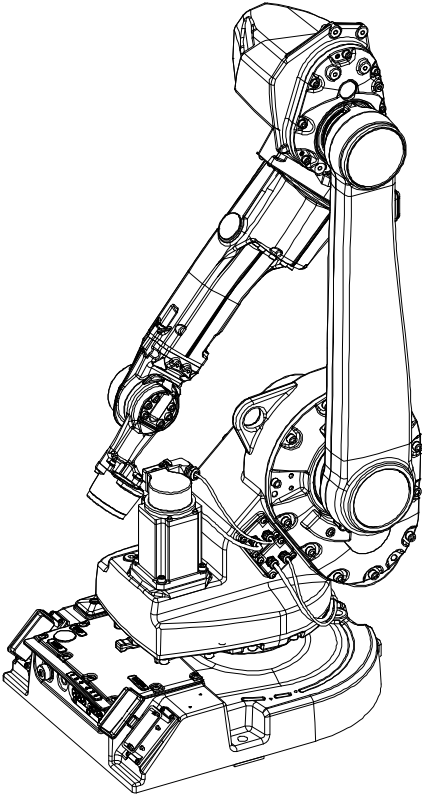

	Action	Note
2	 <b>DANGER</b> Turn off all: <ul style="list-style-type: none"> <li>• electric power supply</li> <li>• hydraulic pressure supply</li> <li>• air pressure supply</li> </ul> to the robot, before entering the robot working area.	
3	In order to release the brakes, connect the 24 VDC power supply to the motor.	Connect to connector R3.MP3: <ul style="list-style-type: none"> <li>• +: pin 7</li> <li>• -: pin 8</li> </ul>
4	Remove any additional mechanical stops from axis 3.	
5	Move: <ul style="list-style-type: none"> <li>• axis 2 to calibration position</li> <li>• upper arm backwards against the mechanical stop</li> </ul> This position enables removal of the motor without draining oil of the gearbox, axis 3.	 <p style="text-align: right; font-size: small;">xx0700000010</p>
6	Remove the <i>upper arm housing cover</i> .	Shown in the figure <a href="#">Location of motor on page 273</a>
7	Disconnect the motor connectors R3.MP3 and R3.FB3.	Shown in the figure <a href="#">Location of motor on page 273</a>

Continues on next page

## 4 Repair

### 4.6.4 Replacement of motor, axis 3, 1600ID/1660ID

Continued

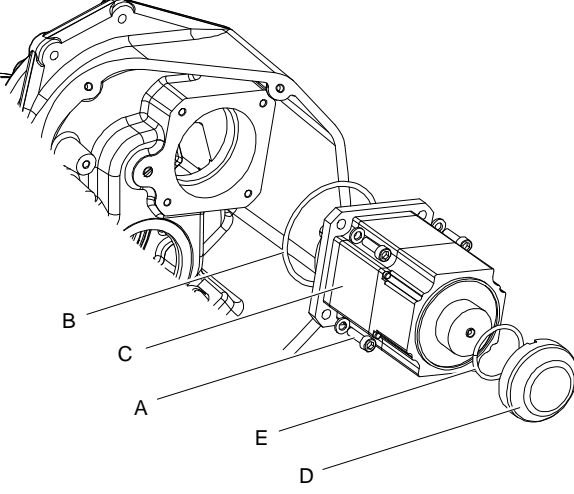
	Action	Note
8	<p> <b>DANGER</b></p> <p>Secure the weight of the upper arm properly before releasing the brakes of motor, axis 3.</p> <p>When releasing the holding brakes of the motor, the upper arm will be movable and fall down!</p>	
9	<p> <b>DANGER</b></p> <p>The motor has a high temperature after running which can occur burns.</p>	
10	<p>Remove the motor, axis 3, by unscrewing its attachment screws and washers.</p> <p>Lift the motor gently straight out, making sure the motor pinion is not damaged.</p>	 <p>xx0700000050</p> <ul style="list-style-type: none"> <li>A Hex socket head cap screw</li> <li>B O-ring</li> <li>C Motor axis 3</li> <li>D Resolver cover</li> <li>E O-ring</li> </ul>
11	<p>Remove the resolver cover for refitting on the new motor.</p>	
12	<p>Disconnect the brake release voltage.</p>	

Continues on next page



## Refitting, motor axis 3

The procedure below details how to refit the axis 3 motor.

	Action	Note
1	 <b>Note</b> It is important that the gearbox and the mating motor pinion are provided by the same sub-supplier, make sure to order the correct spare part! To determine the correct spare part, see <i>Compatible gearboxes and motors</i> in <i>Product manual, spare parts - IRB 1600/1660</i> .	
2	Clean the mating surfaces inside the upper arm housing and on the motor with Isopropanol.	
3	Make sure the <i>o-ring</i> on the circumference of the motor is seated properly. Lubricate it with grease.	Replace the o-ring if damaged. Part number is specified in section <a href="#">Required equipment on page 268</a> .
4	Fit the new motor to the upper arm housing, making sure the motor pinion is properly mated to the gear of axis 3.	
5	Fit the <i>attachment screws and washers</i> but do not tighten them yet.	4 pcs, M6 x 20. Shown in the figure <a href="#">Location of motor on page 273</a> .
6	Fit the <i>rotation tool</i> to the end of the motor shaft.	Part number is specified in <a href="#">Required equipment on page 268</a> .
7	Adjust the motor in relation to the gear. Use the rotation tool to wiggle the motor shaft back and forth to feel the play.	There should be a barely noticeable gear play.
8	Tighten the motor attachment screws.	<b>Tightening torque: 10 Nm.</b>
9	Refit the resolver cover on the new motor.	
10	Reconnect the motor connectors, run and secure the cabling correctly inside the upper arm housing.	Cable layout is shown in the figure <a href="#">Illustration, cabling inside upper arm housing on page 166</a> .
11	Refit the <i>cover, upper arm housing</i> .	Shown in the figure <a href="#">Location of motor on page 273</a> . Art. no. is specified in section <a href="#">Required equipment on page 268</a> .
12	Refit any additional mechanical stops.	Detailed in section <a href="#">Installation of additional mechanical stops on axis 3 on page 109</a> .
13	Recalibrate the robot.	Pendulum Calibration is described in <i>Operating manual - Calibration Pendulum</i> , enclosed with the calibration tools. Axis Calibration is described in <a href="#">Calibrating with Axis Calibration method on page 349</a> . General calibration information is included in section <a href="#">Calibration on page 337</a> .

Continues on next page

## 4 Repair

---

### 4.6.4 Replacement of motor, axis 3, 1600ID/1660ID

*Continued*

	Action	Note
14	 <b>DANGER</b> Make sure all safety requirements are met when performing the first test run. These are further detailed in section <i>First test run may cause injury or damage on page 28</i> .	

## 4.6.5 Replacement of motor, axis 4, IRB 1600

## Location of motor

The axis 4 motor is located inside the upper arm housing, as shown in the figure below.

A more detailed view of the component and its position may be found in the spare part view, *Spare parts - Upper arm, exploded view*.

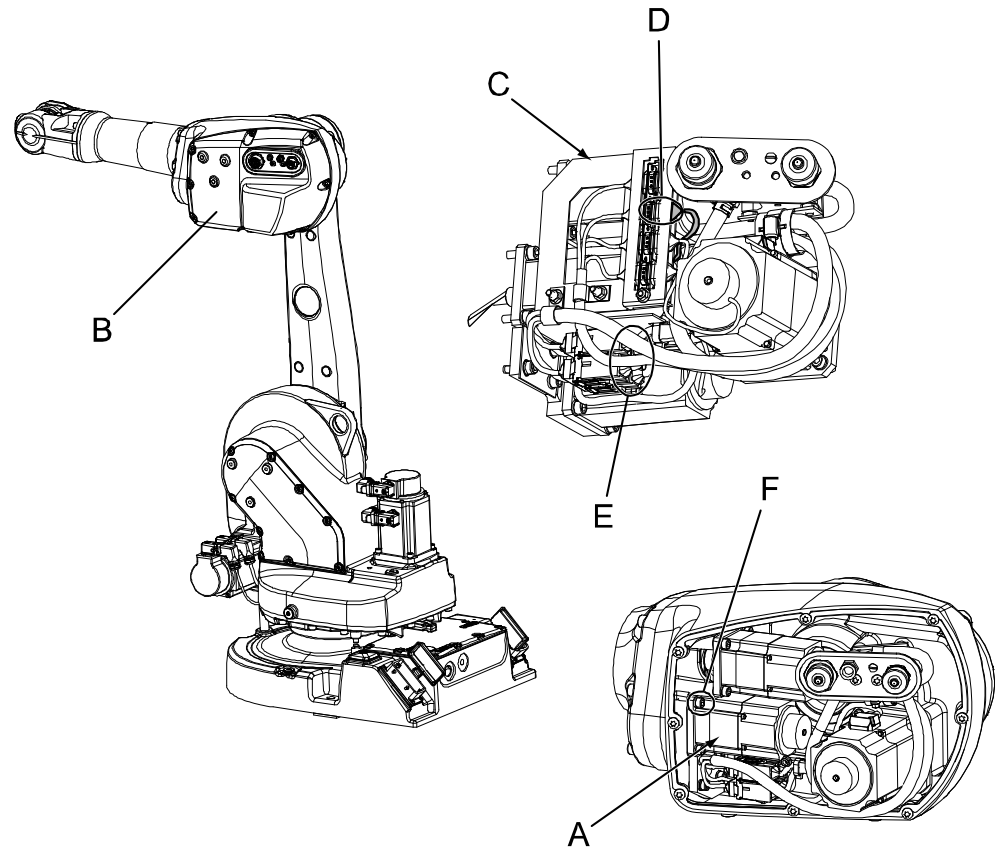

xx0400001273

A	Motor, axis 4
B	Cover, upper arm housing
C	Connector plate
D	Signal connector, R3.FB4
E	Power connector, R3.MP4
F	Attachment screw and washer, motor (4 pcs)

## Required equipment

Equipment, etc.	Spare part no.	Art. no.	Note
Rot. ac motor with pinion	For spare part number, see: <ul style="list-style-type: none"> <li><a href="#">Spare part lists on page 387</a></li> </ul>		

Continues on next page

## 4 Repair

### 4.6.5 Replacement of motor, axis 4, IRB 1600

Continued

Equipment, etc.	Spare part no.	Art. no.	Note
O-ring		3HAB3772-81	Replace if damaged.
Gasket, upper arm cover	3HAC022049-001		Replace if damaged.
Gasket, customer connections	3HAC022050-001		Replace if damaged.
Grease		3HAB3537-1	Used for lubricating the o-ring.
Standard toolkit			Content is defined in section <a href="#">Standard tools on page 383</a> .
Power supply		-	24 VDC, max. 1,5 A. For releasing the brakes.
Rotation tool, motor		3HAC022266-003	For adjusting the gear play.
Other tools and procedures may be required. See references to these procedures in the step-by-step instructions below.			These procedures include references to the tools required.
Circuit diagram			See chapter <a href="#">Circuit diagram on page 389</a> .

#### Deciding calibration routine

Decide which calibration routine to be used, based on the information in the table. Depending on which routine is chosen, action might be required prior to beginning the repair work of the robot, see the table.

	Action	Note
1	<p>Decide which calibration routine to use for calibrating the robot.</p> <ul style="list-style-type: none"> <li>Reference calibration. External cable packages (DressPack) and tools can stay fitted on the robot.</li> <li>Fine calibration. All external cable packages (DressPack) and tools must be removed from the robot.</li> </ul>	
	<p><b>If the robot is to be calibrated with reference calibration:</b></p> <p>Find previous reference values for the axis or create new reference values. These values are to be used after the repair procedure is completed, for calibration of the robot.</p> <p>If no previous reference values exist, and no new reference values can be created, then reference calibration is not possible.</p>	<p>Follow the instructions given in the reference calibration routine on the FlexPendant to create reference values.</p> <p>Creating new values requires possibility to move the robot.</p> <p>Read more about reference calibration for Axis Calibration in <a href="#">Reference calibration routine on page 350</a>.</p> <p>Read more about reference calibration for Pendulum Calibration in <i>Operating manual - Calibration Pendulum</i>.</p>
	<p><b>If the robot is to be calibrated with fine calibration:</b></p> <p>Remove all external cable packages (DressPack) and tools from the robot.</p>	



Continues on next page

**CAUTION**

Always cut the paint with a knife and grind the paint edge when disassembling parts. See [Cut the paint or surface on the robot before replacing parts on page 159](#).

**Removal, motor axis 4**

The procedure below details how to remove the motor, axis 4.

	Action	Note
1	Decide which calibration routine to use, and take actions accordingly prior to beginning the repair procedure.	
2	 <b>DANGER</b> Turn off all: <ul style="list-style-type: none"> <li>• electric power supply</li> <li>• hydraulic pressure supply</li> <li>• air pressure supply</li> </ul> to the robot, before entering the robot working area.	
3	 <b>CAUTION</b> Always cut the paint with a knife and grind the paint edge when disassembling parts. See <a href="#">Cut the paint or surface on the robot before replacing parts on page 159</a> .	
4	Manually move the robot to a position where the upper arm points straight down.	This will enable the motor 4 to be removed without draining the oil in the gearbox.
5	Remove the cover from the upper arm housing.	
6	Remove the <i>connector plate</i> to get access to the axis 4 motor.	Shown in the figure <a href="#">Location of motor on page 279</a> .
7	Disconnect the connectors R3.MP4 and R3.FB4 from the axis 4 motor.	
8	In order to release the brakes, connect the 24 VDC power supply to the motor.	Connect to connector R3.MP4 <ul style="list-style-type: none"> <li>• +: pin 7</li> <li>• -: pin 8</li> </ul>
9	Remove the <i>motor, axis 4</i> by unscrewing the motor attachment screws.	Shown in the figure <a href="#">Location of motor on page 279</a> .
10	Lift the motor to get the pinion away from the gear and disconnect the brake release voltage.	
11	Remove the motor by gently lifting it out.	Make sure the motor pinion is not damaged!

Continues on next page

## 4 Repair

### 4.6.5 Replacement of motor, axis 4, IRB 1600

Continued

#### Refitting, motor axis 4

The procedure below details how to refit the motor, axis 4.

	Action	Note
1	Clean the joints that have been opened. See <a href="#">Cut the paint or surface on the robot before replacing parts on page 159</a>	
2	Clean the mating surfaces on the <i>motor</i> and the gearbox.	Shown in the figure <a href="#">Location of motor on page 279</a> .
3	Make sure the <i>o-ring</i> on the circumference of the motor is seated properly. Lightly lubricate the <i>o-ring</i> with <i>grease</i> .	Art. no. is specified in section <a href="#">Required equipment on page 279</a> .
4	In order to release the brakes, connect the 24 VDC power supply to the motor.	Connect to connector R3.MP4 <ul style="list-style-type: none"> <li>• +: pin 7</li> <li>• -: pin 8</li> </ul>
5	Fit the motor with the <i>attachment screws</i> and washers. Until the motor shaft is adjusted to the gear, as described in following steps, only tighten the screws lightly.	Shown in the figure <a href="#">Location of motor on page 279</a> . Tightening torque: approx. 2 Nm. 4 pcs, M6 x 20.
6	Fit the <i>rotational tool</i> to the end of the motor shaft.	Art. no. is specified in section <a href="#">Required equipment on page 279</a> .
7	Adjust the motor in relation to the gear in the gearbox. Use the arm tool to wiggle the motor shaft back and forth to feel the play.	There should be a barely noticeable gear play.
8	Tighten the motor <i>attachment screws</i> .	Shown in the figure <a href="#">Location of motor on page 279</a> . Tightening torque: 10 Nm.
9	Reconnect the motor connectors R3.MP4 and R3.FB4.	
10	Refit the <i>connector plate</i> .	Shown in the figure <a href="#">Location of motor on page 279</a> .
11	Make sure all the cabling is placed correctly inside the upper arm housing.	Cable layout is shown in the figure <a href="#">Illustration, cabling inside upper arm housing on page 166</a> .
12	Refit the cover to the upper arm housing. Check both the <i>gaskets</i> and replace, if damaged.	Art. no. is specified in <a href="#">Required equipment on page 279</a> .
13	Perform a leak-down test.	Detailed in section <a href="#">Performing a leak-down test on page 154</a> .
14	Seal and paint the joints that have been opened. See <a href="#">Cut the paint or surface on the robot before replacing parts on page 159</a>	
	 <b>Note</b> After all repair work, wipe the robot free from particles with spirit on a lint free cloth.	

Continues on next page

	Action	Note
15	Recalibrate the robot!	<p>Pendulum Calibration is described in <i>Operating manual - Calibration Pendulum</i>, enclosed with the calibration tools.</p> <p>Axis Calibration is described in <i>Calibrating with Axis Calibration method on page 349</i>.</p> <p>General calibration information is included in section <i>Calibration on page 337</i>.</p>
16	 <b>DANGER</b> Make sure all safety requirements are met when performing the first test run. These are further detailed in the section <i>First test run may cause injury or damage on page 28</i> .	

## 4 Repair

### 4.6.6 Replacement of motor, axis 4, 1600ID/1660ID

### 4.6.6 Replacement of motor, axis 4, 1600ID/1660ID



#### Note

After replacement of motors/motor in a manipulator, recalibration is required.

#### Location of motor

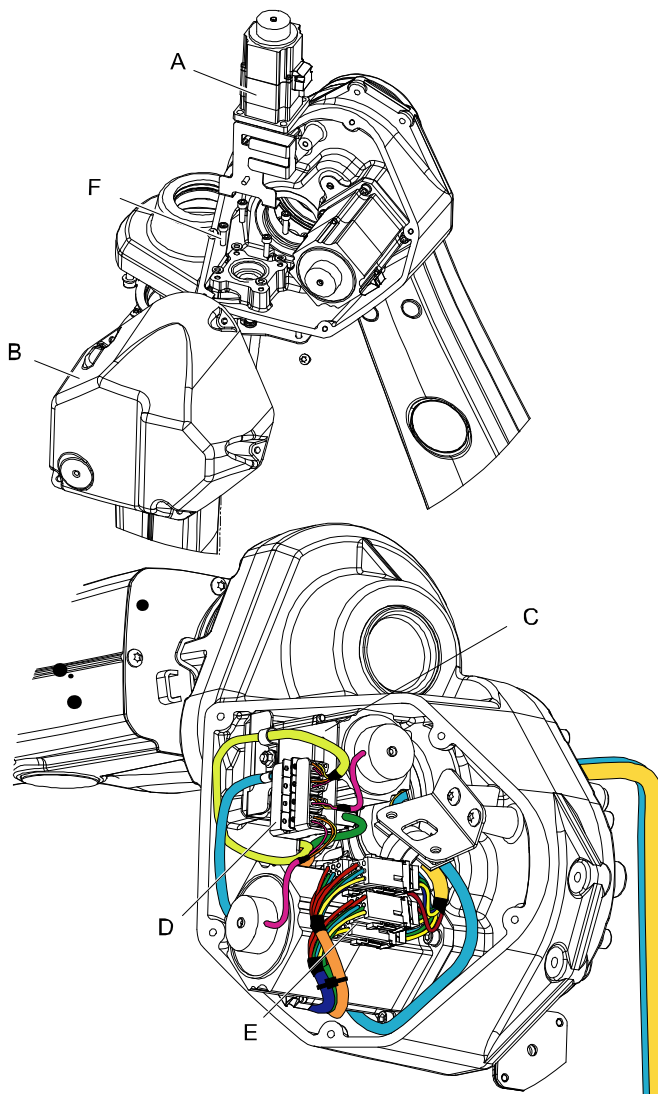

xx0700000017

A	Motor, axis 4
B	Cover, upper arm housing
C	Connector plate
D	Signal connector, R3.FB4
E	Power connector, R3.MP4
F	Attachment screw and washer, motor (4 pcs)

Continues on next page



## Required equipment

Equipment, etc.	Art. no.	Note
Rot. ac motor incl pinion	For spare part number, see: <ul style="list-style-type: none"> <li><a href="#">Spare part lists on page 387</a></li> </ul>	
O-ring	3HAB3772-81	
Standard toolkit		The contents are defined in section <a href="#">Standard tools on page 383</a> .
Power supply	-	24 VDC, max. 1,5 A. For releasing the brakes.
Rotation tool, motor		For adjusting the gear play.
Other tools and procedures may be required. See references to these procedures in the step-by-step instructions below.		These procedures include references to the tools required.
Circuit diagram		See <a href="#">Circuit diagram on page 389</a> .
Pendulum Calibration tool		See <a href="#">Special tools on page 384</a> .

**CAUTION**

Always cut the paint with a knife and grind the paint edge when disassembling parts. See [Cut the paint or surface on the robot before replacing parts on page 159](#).

## Deciding calibration routine

Decide which calibration routine to be used, based on the information in the table. Depending on which routine is chosen, action might be required prior to beginning the repair work of the robot, see the table.

	Action	Note
1	Decide which calibration routine to use for calibrating the robot. <ul style="list-style-type: none"> <li>Reference calibration. External cable packages (DressPack) and tools can stay fitted on the robot.</li> <li>Fine calibration. All external cable packages (DressPack) and tools must be removed from the robot.</li> </ul>	
	<b>If the robot is to be calibrated with reference calibration:</b> Find previous reference values for the axis or create new reference values. These values are to be used after the repair procedure is completed, for calibration of the robot. If no previous reference values exist, and no new reference values can be created, then reference calibration is not possible.	Follow the instructions given in the reference calibration routine on the FlexPendant to create reference values. Creating new values requires possibility to move the robot. Read more about reference calibration for Axis Calibration in <a href="#">Reference calibration routine on page 350</a> . Read more about reference calibration for Pendulum Calibration in <a href="#">Operating manual - Calibration Pendulum</a> .

Continues on next page



## 4 Repair

### 4.6.6 Replacement of motor, axis 4, 1600ID/1660ID

Continued

Action	Note
<p>If the robot is to be calibrated with fine calibration: Remove all external cable packages (DressPack) and tools from the robot.</p>	

#### Removal, motor axis 4

Action	Note
1 Decide which calibration routine to use, and take actions accordingly prior to beginning the repair procedure.	
<p> <b>DANGER</b></p> <p>Turn off all:</p> <ul style="list-style-type: none"> <li>• electric power supply</li> <li>• hydraulic pressure supply</li> <li>• air pressure supply</li> </ul> <p>to the robot, before entering the robot working area.</p>	
3 Remove the cover from the upper arm housing.	
4 Remove the <i>connector plate</i> to get access to the axis 4 motor.	Shown in the figure <a href="#">Location of motor on page 284</a> .
5 Disconnect the connectors R3.MP4 and R3.FB4 from the axis 4 motor.	
<p> <b>DANGER</b></p> <p>The motor has a high temperature after running which can occur burns.</p>	
7 Remove the <i>motor, axis 4</i> by unscrewing the motor attachment screws.	Shown in the figure <a href="#">Location of motor on page 284</a> .
8 Lift the motor to get the pinion away from the gear and disconnect the brake release voltage.	
9 Remove the motor by gently lifting it out.	Make sure the motor pinion is not damaged!

#### Refitting, motor axis 4

Action	Note
1 Clean the mating surfaces on the <i>motor</i> and the gearbox.	Shown in the figure <a href="#">Location of motor on page 284</a> .
2 Make sure the <i>o-ring</i> on the circumference of the motor is seated properly. Lightly lubricate the <i>o-ring</i> with <i>grease</i> .	Art. no. is specified in section.
<p>Fit the motor with the <i>attachment screws</i> and washers.</p> <p>Until the motor shaft is adjusted to the gear, as described in following steps, only tighten the screws lightly.</p>	<p>Shown in the figure <a href="#">Location of motor on page 284</a>.</p> <p><b>Tightening torque: approx. 2 Nm.</b> 4 pcs, M6 x 20.</p>

Continues on next page

	Action	Note
4	Tighten the motor <i>attachment screws</i> .	Shown in the figure <a href="#">Location of motor on page 284</a> . Tightening torque: 10 Nm.
5	Reconnect the motor connectors R3.MP4 and R3.FB4.	
6	Refit the <i>connector plate</i> .	Shown in the figure <a href="#">Location of motor on page 284</a> .
7	Refit the cover to the upper arm housing.	
8	Recalibrate the robot.	Pendulum Calibration is described in <i>Operating manual - Calibration Pendulum</i> , enclosed with the calibration tools. Axis Calibration is described in <a href="#">Calibrating with Axis Calibration method on page 349</a> . General calibration information is included in section <a href="#">Calibration on page 337</a> .

## 4 Repair

### 4.6.7 Replacement of motor and timing belt, axis 5, IRB 1600

### 4.6.7 Replacement of motor and timing belt, axis 5, IRB 1600

#### Location of motor

The motor and timing belt of axis 5 is located inside the upper arm housing, as shown in the figure below.

A more detailed view of the motor and its position may be found in the spare part view, *Spare parts - Upper arm, exploded view*.

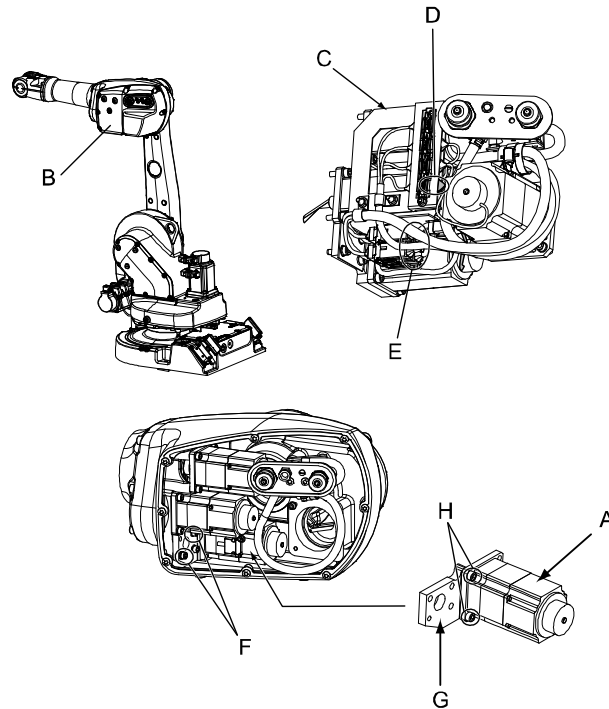

xx0400001279

A	Motor, axis 5
B	Cover, upper arm housing
C	Connector plate
D	Signal cable, motor 5: R3.FB5
E	Power cable, motor 5: R3.MP5
F	Attachment screws and washers, motor bracket (2 pcs)
G	Motor bracket
H	Attachment screws and washers, motor (3 pcs)

#### Required equipment

Equipment	Spare part no.	Art. no.	Note
Rot. ac motor incl pinion	3HAC021800-003		
Timing belt	3HAC021304-001		
Gasket, upper arm cover	3HAC022049-001		Replace if damaged.
Gasket, customer connections	3HAC022050-001		Replace if damaged.

*Continues on next page*

Equipment	Spare part no.	Art. no.	Note
Belt tightener		3HAC024044-001	
Dynamometer		-	Capacity: 100N
Standard toolkit			Content is defined in section <a href="#">Standard tools on page 383</a> .
Other tools and procedures may be required. See references to these procedures in the step-by-step instructions below.			These procedures include references to the tools required.
Circuit diagram			See chapter <a href="#">Circuit diagram on page 389</a> .

### Belt tightener, 3HAC 024044-001

The belt tightener is a special tool that is used when adjusting the tension of the timing belt of axis 5. The length of the tool is important, since the tool is pulled with a given force.

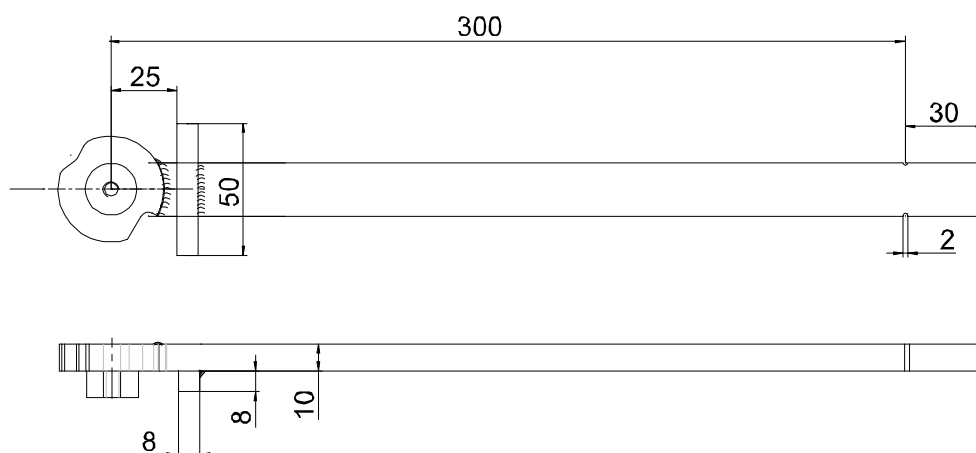

xx0500001457



#### CAUTION

Always cut the paint with a knife and grind the paint edge when disassembling parts. See [Cut the paint or surface on the robot before replacing parts on page 159](#).

Continues on next page

## 4 Repair

### 4.6.7 Replacement of motor and timing belt, axis 5, IRB 1600

Continued

#### Deciding calibration routine

Decide which calibration routine to be used, based on the information in the table. Depending on which routine is chosen, action might be required prior to beginning the repair work of the robot, see the table.

	Action	Note
1	Decide which calibration routine to use for calibrating the robot. <ul style="list-style-type: none"> <li>Reference calibration. External cable packages (DressPack) and tools can stay fitted on the robot.</li> <li>Fine calibration. All external cable packages (DressPack) and tools must be removed from the robot.</li> </ul>	
	<b>If the robot is to be calibrated with reference calibration:</b> Find previous reference values for the axis or create new reference values. These values are to be used after the repair procedure is completed, for calibration of the robot.  If no previous reference values exist, and no new reference values can be created, then reference calibration is not possible.	Follow the instructions given in the reference calibration routine on the FlexPendant to create reference values. Creating new values requires possibility to move the robot. Read more about reference calibration for Axis Calibration in <a href="#">Reference calibration routine on page 350</a> . Read more about reference calibration for Pendulum Calibration in <i>Operating manual - Calibration Pendulum</i> .
	<b>If the robot is to be calibrated with fine calibration:</b> Remove all external cable packages (DressPack) and tools from the robot.	

#### Removal, motor axis 5 and timing belt

The procedure below details how to remove the motor and the timing belt of axis 5.

	Action	Note
1	Decide which calibration routine to use, and take actions accordingly prior to beginning the repair procedure.	
2	 <b>DANGER</b>  Turn off all: <ul style="list-style-type: none"> <li>electric power supply</li> <li>hydraulic pressure supply</li> <li>air pressure supply</li> </ul> to the robot, before entering the robot working area.	
3	Remove the axis 4 motor.	Detailed in section <a href="#">Removal, motor axis 4 on page 281</a> .
4	Remove the motor and timing belt of axis 6.	Detailed in section <a href="#">Removal, motor and timing belt, axis 6 on page 313</a> .
5	Disconnect the axis 5 motor connectors: R3.MP5 and R3.FB5.	

Continues on next page

## 4.6.7 Replacement of motor and timing belt, axis 5, IRB 1600

Continued

	Action	Note
6	Move aside all cabling that is hindering access to the axis 5 motor.	
7	Remove the <i>motor bracket</i> , including the motor, by unscrewing the two <i>attachment screws and washers</i> .	Shown in the figure <a href="#">Location of motor on page 288</a> .
8	Remove the timing belt of axis 5.	
9	Remove the motor bracket from the motor.	

## Refitting, motor and timing belt axis 5

The procedure below details how to refit the motor and timing belt of axis 5.

	Action	Note/Illustration
1	 <p><b>DANGER</b></p> <p>Turn off all:</p> <ul style="list-style-type: none"> <li>• electric power supply</li> <li>• hydraulic pressure supply</li> <li>• air pressure supply</li> </ul> <p>to the robot, before entering the robot working area.</p>	
2	Clean the mating surfaces on the motor and in the upper arm housing.	
3	Fit the new motor to the motor bracket, previously removed from the old motor.	3 pcs, M6 x 20.

Continues on next page

## 4 Repair

### 4.6.7 Replacement of motor and timing belt, axis 5, IRB 1600

Continued

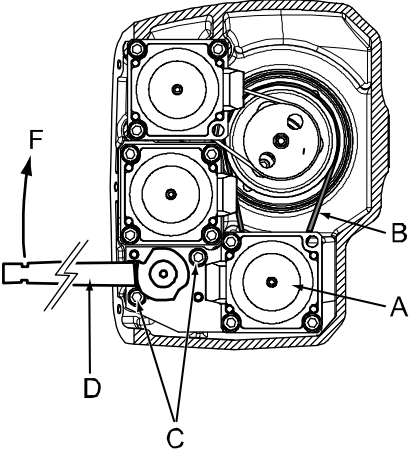
	Action	Note/Illustration
4	<p>Follow the steps below when fitting the motor:</p> <ul style="list-style-type: none"> <li>• Place the timing belt (B) round the motor pinion and place the belt round the axis 5 as fitting the motor in the upper arm housing.</li> <li>• Fasten the motor bracket with two attachment screws (C), but do not tighten the screws yet. Use correct attachment holes, shown in the figure to the right!</li> <li>• Adjust the belt tension by pulling the motor bracket, using the <i>belt tightener</i> and <i>dynamometer</i>, as shown in the figure to the right.</li> <li>• Tighten the two attachment screws of the bracket (C) with a torque of 10 Nm.</li> </ul>	<p>Art. no. is specified in <a href="#">Required equipment on page 288</a>.</p>  <p>xx0400001280</p> <ul style="list-style-type: none"> <li>A Motor axis 5</li> <li>B Timing belt, axis 5</li> <li>C Attachment screws and washers, motor bracket, 2 pcs, M6 x 20</li> <li>D Belt tightener, the dimensions are shown in the figure <a href="#">Belt tightener, 3HAC 024044-001 on page 289</a>.</li> </ul> <p>F (Force): 24 N.</p>
5	Refit the motor and timing belt of axis 6.	Detailed in section <a href="#">Refitting, motor and timing belt, axis 6 on page 313</a> .
6	Refit the motor of axis 4.	Detailed in section <a href="#">Refitting, motor axis 4 on page 282</a> .
7	Reconnect all connectors and place the cabling correctly inside the upper arm housing.	Cable layout shown in the figure <a href="#">Illustration, cabling inside upper arm housing on page 166</a> .
8	Refit the cover to the upper arm housing. Check both the <i>gaskets</i> and replace, if damaged.	Art.no. is specified in <a href="#">Required equipment on page 288</a> .
9	Recalibrate the robot!	<p>Pendulum Calibration is described in <a href="#">Operating manual - Calibration Pendulum</a>, enclosed with the calibration tools.</p> <p>Axis Calibration is described in <a href="#">Calibrating with Axis Calibration method on page 349</a>.</p> <p>General calibration information is included in section <a href="#">Calibration on page 337</a>.</p>

Continues on next page



	Action	Note/Illustration
10	 <b>DANGER</b> Make sure all safety requirements are met when performing the first test run. These are further detailed in the section <i>First test run may cause injury or damage on page 28.</i>	

## 4 Repair

### 4.6.8 Replacement of motor, axis 5, IRB 1600ID

### 4.6.8 Replacement of motor, axis 5, IRB 1600ID



#### Note

After replacement of motors/motor in a manipulator, recalibration is required.

#### Location of motor, axis 5

The motor of axes 5 is located inside the upper arm as shown in the figure below.

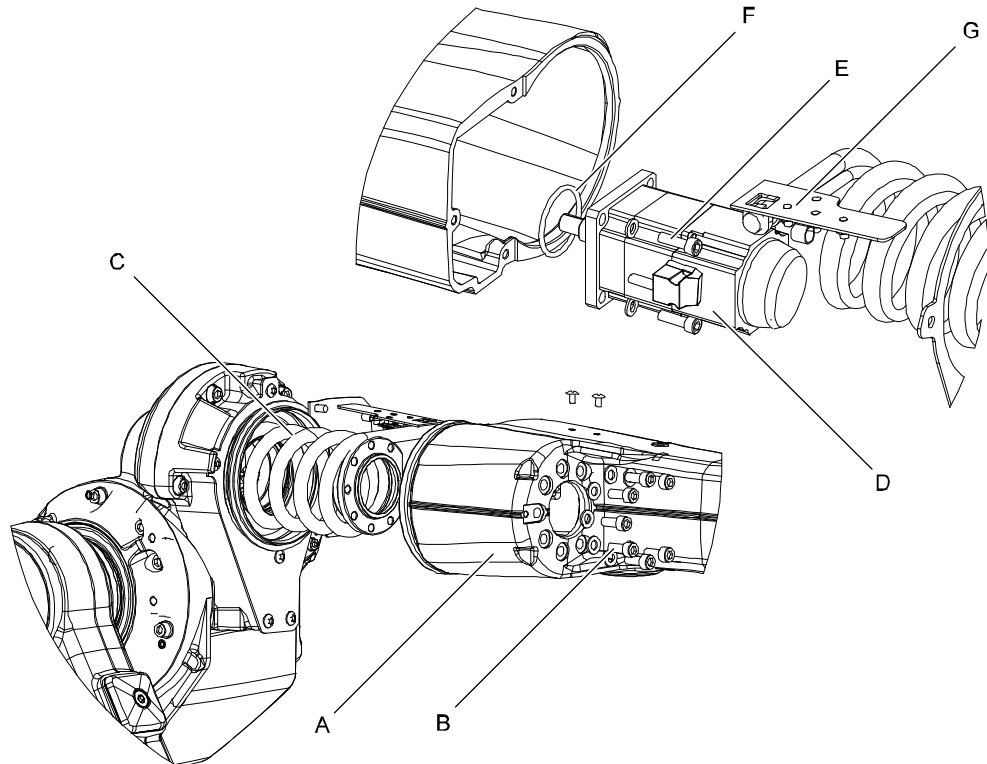

xx070000020

A	Arm Tube
B	Hex socket head cap screw M8X20
C	Cable harness IRB1600ID
D	Rotational ac motor Axis 5
E	Hex. socket head cap screw M6X20
F	O-ring
G	Cable harness bracket

#### Required equipment

Equipment, etc.	Art. no.	Note
Rot. ac motor with pinion	For spare part number, see: <ul style="list-style-type: none"><li><a href="#">Spare part lists on page 387</a></li></ul>	
VK cover	3HAA2166-19	

Continues on next page

Equipment, etc.	Art. no.	Note
Standard toolkit	-	The contents are defined in section <a href="#">Standard tools on page 383</a> , in part 2 of the Product manual.
Other tools and procedures may be required. See references to these procedures in the step-by-step instructions below.		These procedures include references to the tools required.
Circuit diagram	3HAC6816-3	See chapter <a href="#">Circuit diagram on page 389</a> .
O-ring	3HAB3772-81	Nitrite
Cable grease		
Isopropanol		

**CAUTION**

Always cut the paint with a knife and grind the paint edge when disassembling parts. See [Cut the paint or surface on the robot before replacing parts on page 159](#).

**Deciding calibration routine**

Decide which calibration routine to be used, based on the information in the table. Depending on which routine is chosen, action might be required prior to beginning the repair work of the robot, see the table.

	Action	Note
1	Decide which calibration routine to use for calibrating the robot. <ul style="list-style-type: none"> <li>Reference calibration. External cable packages (DressPack) and tools can stay fitted on the robot.</li> <li>Fine calibration. All external cable packages (DressPack) and tools must be removed from the robot.</li> </ul>	
	<b>If the robot is to be calibrated with reference calibration:</b> Find previous reference values for the axis or create new reference values. These values are to be used after the repair procedure is completed, for calibration of the robot. If no previous reference values exist, and no new reference values can be created, then reference calibration is not possible.	Follow the instructions given in the reference calibration routine on the FlexPendant to create reference values. Creating new values requires possibility to move the robot. Read more about reference calibration for Axis Calibration in <a href="#">Reference calibration routine on page 350</a> . Read more about reference calibration for Pendulum Calibration in <i>Operating manual - Calibration Pendulum</i> .
	<b>If the robot is to be calibrated with fine calibration:</b> Remove all external cable packages (DressPack) and tools from the robot.	

Continues on next page

## 4 Repair

### 4.6.8 Replacement of motor, axis 5, IRB 1600ID

Continued

#### Removal, motor axis 5

The procedure below details how to remove motor, axis 5.



#### WARNING

Please observe the following before commencing any repair work on the manipulator:

- Motors and gears are HOT after running the robot! Touching the motors and gears may result in burns!
- Turn off all electric power, hydraulic and pneumatic pressure supplies to the robot!
- Take any necessary measures to ensure that the manipulator does not collapse as parts are removed, e.g. secure the lower arm with fixtures if removing motor, axis 2.



#### Note

Whenever parting/mating motor and gearbox, the gears may be damaged if excessive force is used.

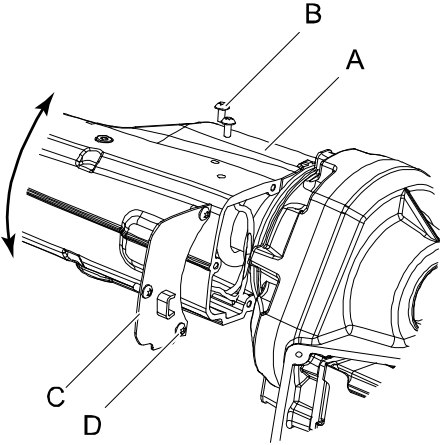
	Action	Note
1	Decide which calibration routine to use, and take actions accordingly prior to beginning the repair procedure.	
2	<p>Remove the cover (C) on the back of the upper arm tube (A). Rotate the upper arm to access all the screws (D). Remove the screws (B) holding the cable harness.</p> <p> <b>CAUTION</b></p> <p>After removal of the cover (mec stop), do not rotate axis 4 do to risk of cable harness damage.</p>	 <p>xx0700000083</p> <p>A Arm Tube B Torx pan head screw M6X12 C Cover D Torx pan head screw M6X12</p>

Continues on next page

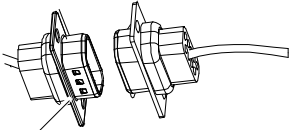
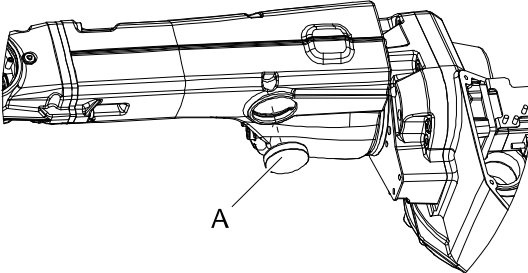

	Action	Note
3	 <p><b>DANGER</b></p> <p>Turn off all:</p> <ul style="list-style-type: none"> <li>• electric power supply</li> <li>• hydraulic pressure supply</li> <li>• air pressure supply</li> </ul> <p>to the robot, before entering the robot working area.</p>	
4	Remove the AW equipment from the upper arm.	Shown in section <a href="#">Remove AW Gun on page 229</a>
5	Disconnect connectors R4.FB5 and R4.MP5, from the back.	 <p>A</p> <p>xx0700000080</p> <p><b>A R4.FB5</b></p>
6	Remove the VK- Cover to access the cable connections inside the arm.	 <p>A</p> <p>xx0700000054</p> <p><b>A VK-Cover</b></p>
7	Gently pull the cables out of the upper arm.	

*Continues on next page*

## 4 Repair

### 4.6.8 Replacement of motor, axis 5, IRB 1600ID

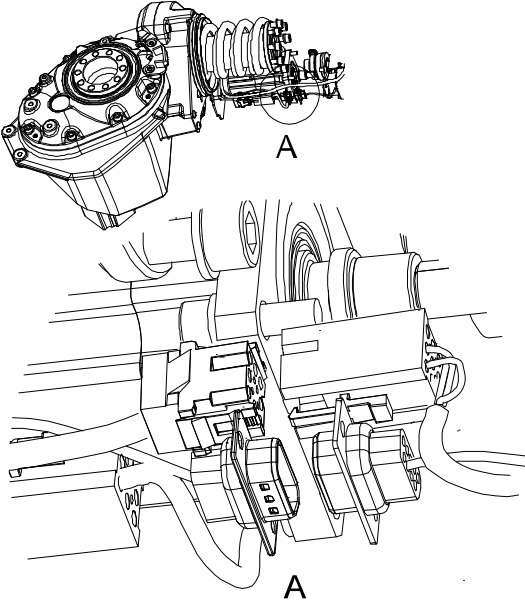
Continued

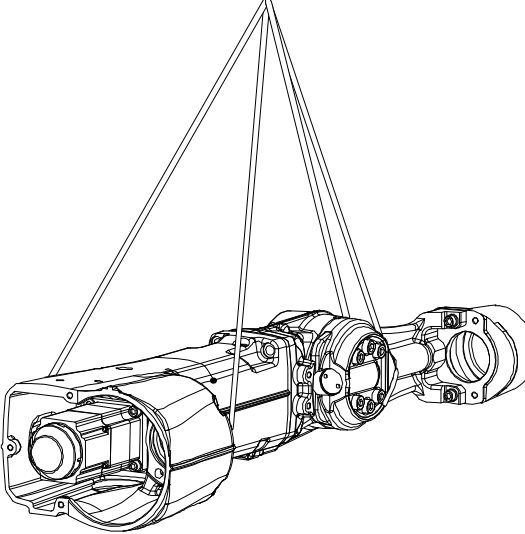
	Action	Note
8	Disconnect through the hole connection R4.FB6 and R4.MP6.	 <p>xx0700000053</p>
9	<p> <b>CAUTION</b></p> <p>The upper arm tube weighs 12.3 kg without any additional equipment fitted. All lifting accessories used must be sized accordingly!</p>	
10	Secure the weight of the arm with lifting slings.	 <p>xx0700000088</p>
11	Remove the seven (7) Hexagon socket head cap screw M8X20, holding the upper arm.	Position (B) in figure <a href="#">Location of motor, axis 5 on page 294</a> .
12	Remove the upper arm.	

Continues on next page

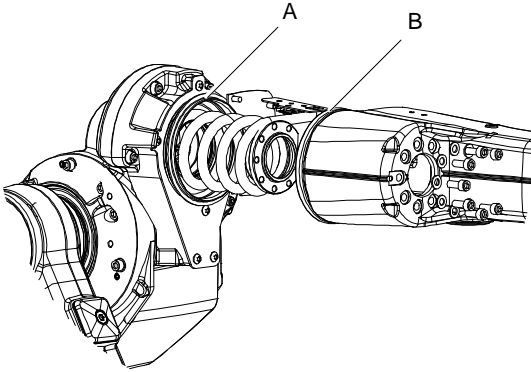
	Action	Note
13	Remove the V-ring (A) and the support ring (B).	 <p data-bbox="901 689 1005 705">xx0700000248</p> <p data-bbox="933 728 1109 784">A V-ring B Support ring</p>
14	Remove the four (4) Hexagon socket head cap screw M6X20 holding motor 5.	Position (E), (D) in figure <a href="#">Location of motor, axis 5 on page 294</a>
15	Remove the O-ring and change it if necessary.	Position (F) in figure <a href="#">Location of motor, axis 5 on page 294</a> .
16	Remove the resolver cover for re-use.	

Refitting, motor axis 5

The procedure below details how to refit the motor of axis 5.

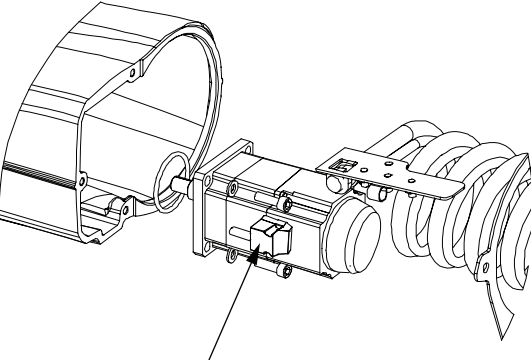

	Action	Note
1	Clean the mating surfaces inside the upper arm housing and on the motor with Isopropanol.	
2	Make sure the o-ring on the circumference of the motor is seated properly. Lubricate it with grease.	Replace the o-ring if damaged. Part number is specified in section <a href="#">Required equipment on page 294</a> .
3	Position the motor into the upper arm housing with the motor connector pointing towards the side, as shown in the figure. Make sure the motor pinion is properly mated to the gear.	 <p data-bbox="901 1780 1005 1796">xx1400001567</p>
4	Fit the attachment screws and washers but do not tighten them yet.	4 pcs, M6 x 20. Shown in the figure <a href="#">Location of motor, axis 5 on page 294</a> .
5	Fit the rotation tool to the end of motor shaft.	Part number is specified in <a href="#">Required equipment on page 294</a>

Continues on next page

## 4 Repair

### 4.6.8 Replacement of motor, axis 5, IRB 1600ID

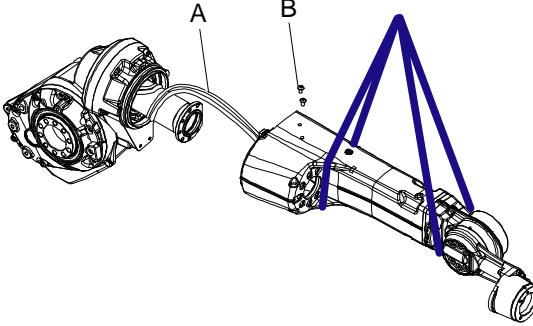
Continued

	Action	Note
6	Adjust the motor in relation to the gear. Use the rotation tool to wiggle the motor shaft back and forth to feel the play.	There should be a barely noticeable gear play.
7	Tighten the motors attachment screws.	Tightening torque: 10Nm
8	Refit the V-ring and support ring.	
9	Refit the cable harness bracket (G) in figure <a href="#">Location of motor, axis 5 on page 294</a> , inside the upper arm tube, use the two torx pan head screw M6X12 (B). Wind the cable harness (A), in a spiral with four free turns around the axis as in figure <a href="#">Location of motor, axis 5 on page 294</a> Grease the cable harness with cable grease.	 <p>xx0700000089</p> <p>A Cable harness B Torx pan head screw M6X12</p>
10	Refitt the upper arm using the 7 Hex socket head cap screw M8X20.	Shown in figure <a href="#">Location of motor, axis 5 on page 294</a> . Tightening torque: 24 Nm
11	Reconnect connections R4.FB6, and R4.MP6 through the VK-hole. Make sure all the cabling is placed correctly inside the upper arm housing.	
12	Reconnect connection R4.FB5 and R4.MP5 from the back.	 <b>Note</b> When reconnecting the connection R4.FB5, make sure to place the connectors as far away from the axis 5-6 cable spiral as possible, to avoid grease to accumulate on the resolver connector.
13	 <b>DANGER</b> Make sure all safety requirements are met when performing the first test run. These are further detailed in the section <a href="#">First test run may cause injury or damage on page 28</a> .	

Continues on next page



	Action	Note
14	<p>Refit the cover (mec stop) on the back of the upper arm tube. Rotate the upper arm to access all tree screws.</p> <p> <b>CAUTION</b></p> <p>Before refitting of the cover (mec stop), do not over rotate axis 4 do to risk of cable harness damage.</p>	
15	Recalibrate the robot.	<p>Pendulum Calibration is described in <i>Operating manual - Calibration Pendulum</i>, enclosed with the calibration tools.</p> <p>Axis Calibration is described in <a href="#">Calibrating with Axis Calibration method on page 349</a>.</p> <p>General calibration information is included in section <a href="#">Calibration on page 337</a>.</p>

## 4 Repair

### 4.6.9 Replacement of motor, axis 5, IRB 1660ID

### 4.6.9 Replacement of motor, axis 5, IRB 1660ID



#### Note

After replacement of motors/motor in a manipulator, recalibration is required.

#### Location of motor axis 5

Motor axis 5 is located inside the upper arm tube as shown in the figure.

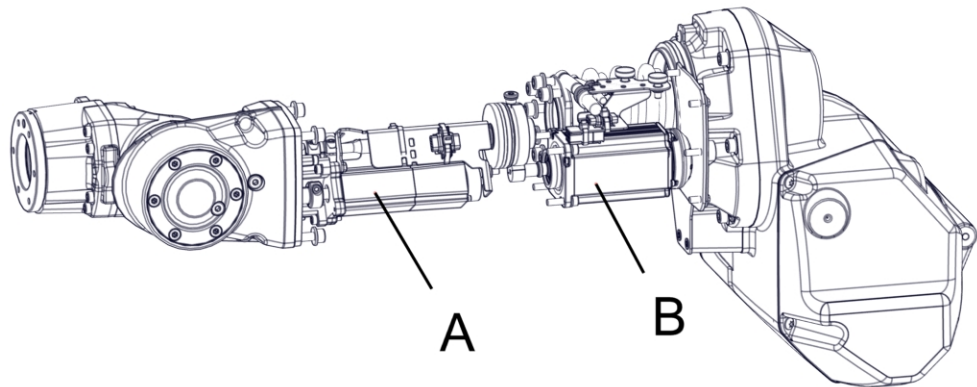

xx1500001258

A	Motor axis 6
B	Motor axis 5

#### Required equipment

Equipment	Art. no.	Note
Sikaflex 521FC	3HAC026759-001	
VK-cover	3HAA2166-17	Always replace with a new when removed.
Standard toolkit	-	Content is defined in section <a href="#">Standard tools on page 383</a> .
Other tools and procedures may be required. See references to these procedures in the step-by-step instructions below.		These procedures include references to the tools required.



#### CAUTION

Always cut the paint with a knife and grind the paint edge when disassembling parts. See [Cut the paint or surface on the robot before replacing parts on page 159](#).

*Continues on next page*

**Deciding calibration routine**

Decide which calibration routine to be used, based on the information in the table. Depending on which routine is chosen, action might be required prior to beginning the repair work of the robot, see the table.

	Action	Note
1	<p>Decide which calibration routine to use for calibrating the robot.</p> <ul style="list-style-type: none"> <li>Reference calibration. External cable packages (DressPack) and tools can stay fitted on the robot.</li> <li>Fine calibration. All external cable packages (DressPack) and tools must be removed from the robot.</li> </ul>	
	<p><b>If the robot is to be calibrated with reference calibration:</b></p> <p>Find previous reference values for the axis or create new reference values. These values are to be used after the repair procedure is completed, for calibration of the robot.</p> <p>If no previous reference values exist, and no new reference values can be created, then reference calibration is not possible.</p>	<p>Follow the instructions given in the reference calibration routine on the FlexPendant to create reference values.</p> <p>Creating new values requires possibility to move the robot.</p> <p>Read more about reference calibration for Axis Calibration in <a href="#">Reference calibration routine on page 350</a>.</p> <p>Read more about reference calibration for Pendulum Calibration in <i>Operating manual - Calibration Pendulum</i>.</p>
	<p><b>If the robot is to be calibrated with fine calibration:</b></p> <p>Remove all external cable packages (DressPack) and tools from the robot.</p>	

**Removing motor axis 5**

Use this procedure to remove motor axis 5.

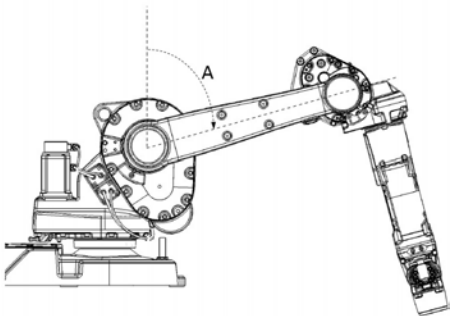

	Action	Information
1	Decide which calibration routine to use, and take actions accordingly prior to beginning the repair procedure.	
2	Move the lower arm to the position shown in the figure.	 <p>xx1500003066</p> <ul style="list-style-type: none"> <li>A: 75° approximately</li> </ul>
3	Move the upper arm to a horizontal position.	

Continues on next page

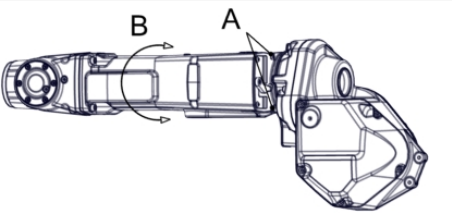

## 4 Repair

### 4.6.9 Replacement of motor, axis 5, IRB 1660ID

Continued

	Action	Information
4	Rotate the upper arm to access the two inner attachment screws securing the cover and remove them.	 <p>xx1500001260</p> <ul style="list-style-type: none"> <li>• A: Inner attachment screws (2 pcs)</li> <li>• B: Directions of rotation</li> </ul>
5	Move the upper arm to sync. position.	For the synchronization positions, see <a href="#">Synchronization marks and synchronization position for axes on page 341</a> .
6	 <p><b>DANGER</b></p> <p>Before entering the robot working area, turn off all:</p> <ul style="list-style-type: none"> <li>• Electric power supply to the robot</li> <li>• Hydraulic pressure supply to the robot</li> <li>• Air pressure supply to the robot</li> </ul>	
7	Remove all extra equipment fitted on the upper arm and wrist.	
8	Remove the wrist and disconnect those cables to motor axis 6.	How to remove the wrist see the section: <ul style="list-style-type: none"> <li>• <a href="#">Replacing the wrist unit, IRB1660ID on page 212</a></li> </ul>
9	 <p><b>Note</b></p> <p>Make a note of the position of axis 4 before continuing the removal process.</p> <p>It is important to refit the mechanical stop and cable harness spiral, with axis 4 in the same position as it was before the removal. If axis 4 has been moved, it must be returned to the position it was when the mechanical stop was removed.</p> <p>This is due to risk of damage to the cable harness.</p>	

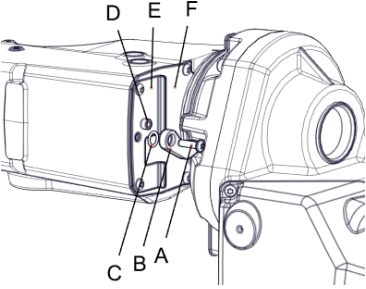
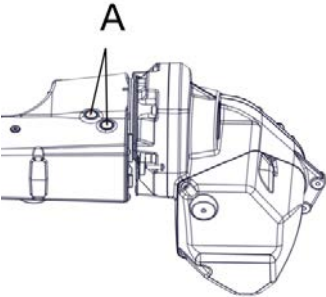
Continues on next page

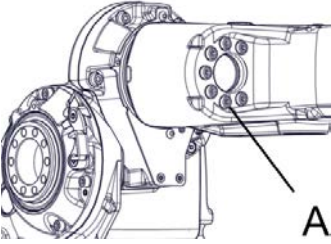



	Action	Information
10	<p>Remove the mechanical stop.</p> <p> <b>Note</b></p> <p>Do not loose the o-ring and distance ring in the removal process!</p>	 <p>xx1500001266</p> <ul style="list-style-type: none"> <li>• A: Attachment screws (5 pcs)</li> <li>• B: Mechanical stop</li> <li>• C: O-ring</li> <li>• D: Distance ring</li> <li>• E: Bracket</li> <li>• F: Cover</li> </ul>
11	Remove the bracket.	See figure above.
12	Remove the cover.	See figure above.
13	Remove the two VK-covers, covering the attachment screws securing the cable harness to the upper arm tube.	 <p>xx1500001265</p> <ul style="list-style-type: none"> <li>• A: VK-covers (2 pcs)</li> </ul>
14	<p>Remove the attachment screws (7 pcs) securing the tube of the armhouse.</p> <p> <b>Note</b></p> <p>The screws are secured with locking liquid Loctite 243.</p>	 <p>xx1500001262</p> <ul style="list-style-type: none"> <li>• A: Attachment screws (7 pcs)</li> </ul>

Continues on next page

## 4 Repair

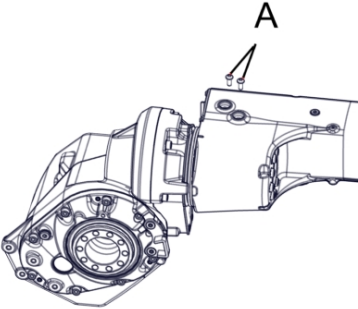
### 4.6.9 Replacement of motor, axis 5, IRB 1660ID

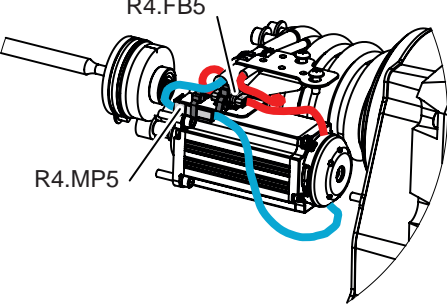
Continued

	Action	Information
15	Remove the attachment screws securing the cable harness bracket to the upper arm tube.	 <p>xx1500001267</p> <ul style="list-style-type: none"><li>• A: Attachment screws (2 pcs)</li></ul>
16	Pull carefully out the upper arm tube a little. Not more than it is possible to reach the connectors for motor axis 5.   <b>CAUTION</b> Be careful not to damage the cable harness in the process. The space is cramped.	
17	Disconnect connectors R4.MP5 and R4.FB5 to motor axis 5.	 <p>xx1400002576</p>
18	Remove the upper arm tube with the cable harness to motor axis 6.   <b>CAUTION</b> Be careful not to damage the cable harness to motor axis 6 in the process.	

Continues on next page

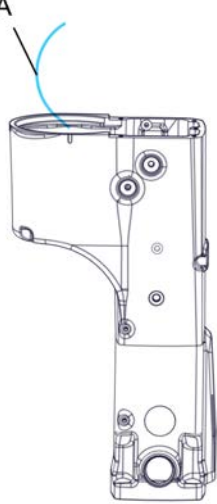
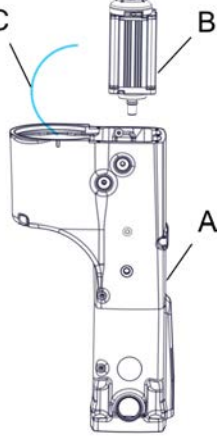
	Action	Information
19	<p>Secure the upper arm tube with motor axis 5 pointing upwards.</p> <p>This is to avoid draining the oil when motor axis 5 is removed.</p>	 <p>xx1500001263</p> <ul style="list-style-type: none"> <li>A: Cable harness to motor axis 6</li> </ul>
20	<p>Remove motor axis 5 by unscrewing its attachment screws.</p>	 <p>xx1500001264</p> <ul style="list-style-type: none"> <li>A: Upper arm tube</li> <li>B: Motor axis 5</li> <li>C: Cable harness to motor axis 6</li> </ul>

**Refitting motor axis 5**

Use this procedure to refit motor axis 5.

	Action	Information
1	Place motor axis 5 in the upper arm tube.	

Continues on next page

## 4 Repair

### 4.6.9 Replacement of motor, axis 5, IRB 1660ID

Continued

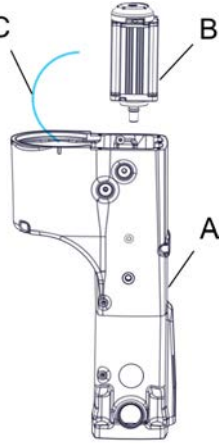
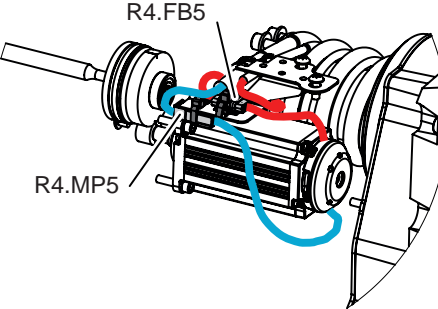
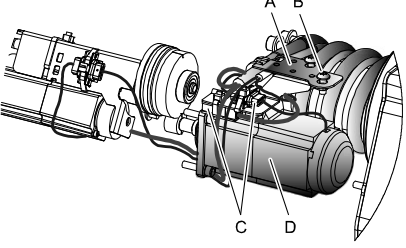
	Action	Information
2	Tighten the attachment screws just enough to still be able to move the motor.	 <p>xx1500001264</p> <ul style="list-style-type: none"> <li>• A: Upper arm tube</li> <li>• B: Motor axis 5</li> <li>• C: Cable harness to motor axis 6</li> </ul>
3	Adjust the play by finding the smallest play.	
4	Secure the motor with its attachment screws.	Tightening torque: 10 Nm
5	Lift the upper arm tube to the robot.	
6	Connect connectors R4.MP5 and R4.FB5 to motor axis 5.	 <p>xx1400002576</p>
7	Secure the cable harness with its attachment screws to the upper arm tube.	 <p>xx1000000998</p> <ul style="list-style-type: none"> <li>A Bracket</li> <li>B Attachment screws (2 pcs)</li> <li>C Connectors motor axis 5</li> <li>D Motor axis 5</li> </ul>
8	Examine the spiral of the cable harness to make sure it is fitted correctly.	See section <ul style="list-style-type: none"> <li>• <a href="#">Replacing the cable harness, 1600ID/1660ID on page 172</a></li> </ul>

Continues on next page



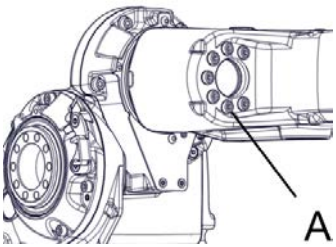
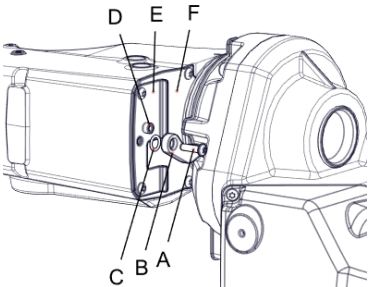
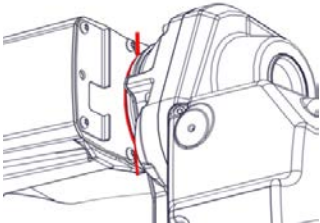

	Action	Information
9	Secure the upper arm tube with attachment screws. Use locking liquid Loctite 243.	Tightening torque: 26 Nm  xx1500001262 A Attachment screws (7 pcs)
10	Refit the cover with two inner attachment screws.	 xx1500001266 <ul style="list-style-type: none"> <li>• A: Attachment screws (5 pcs)</li> <li>• B: Mechanical stop</li> <li>• C: O-ring</li> <li>• D: Distance ring</li> <li>• E: Bracket</li> <li>• F: Cover</li> </ul>
11	Refit the bracket with the remaining attachment screws.	See figure above.
12	Apply Sikaflex 521FC on the surface along the red curve in the figure.	 xx1500001269
13	Refit the mechanical stop.	

Continues on next page

## 4 Repair

### 4.6.9 Replacement of motor, axis 5, IRB 1660ID

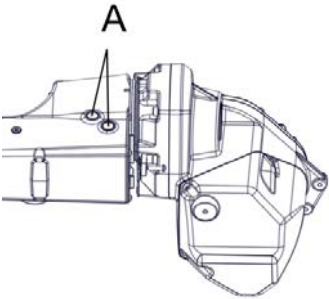
Continued

	Action	Information
14	Fit two new VK-covers.	<p>Article number is specified in <a href="#">Required equipment on page 302</a>.</p>  <p>xx1500001265</p> <p><b>A</b> VK-covers (2 pcs)</p>
15	Connect the cable to motor axis 6.	
16	Refit the wrist.	<p>See section</p> <ul style="list-style-type: none"> <li>• <a href="#">Replacing the wrist unit, IRB1660ID on page 212</a></li> </ul>
17	Recalibrate the robot.	<p>Pendulum Calibration is described in <i>Operating manual - Calibration Pendulum</i>, enclosed with the calibration tools.</p> <p>Axis Calibration is described in <a href="#">Calibrating with Axis Calibration method on page 349</a>.</p> <p>General calibration information is included in section <a href="#">Calibration on page 337</a>.</p>
18	 <p><b>DANGER</b></p> <p>Make sure all safety requirements are met when performing the first test run. These are further detailed in the section <a href="#">First test run may cause injury or damage on page 28</a>.</p>	

## 4.6.10 Replacement of motor and timing belt, axis 6, IRB 1600

## Location of motor

The motor and timing belt of axis 6 are located inside the upper arm housing, as shown in the figure below.

A more detailed view of the motor and its position may be found in the spare part view, *Spare parts - Upper arm, exploded view*.

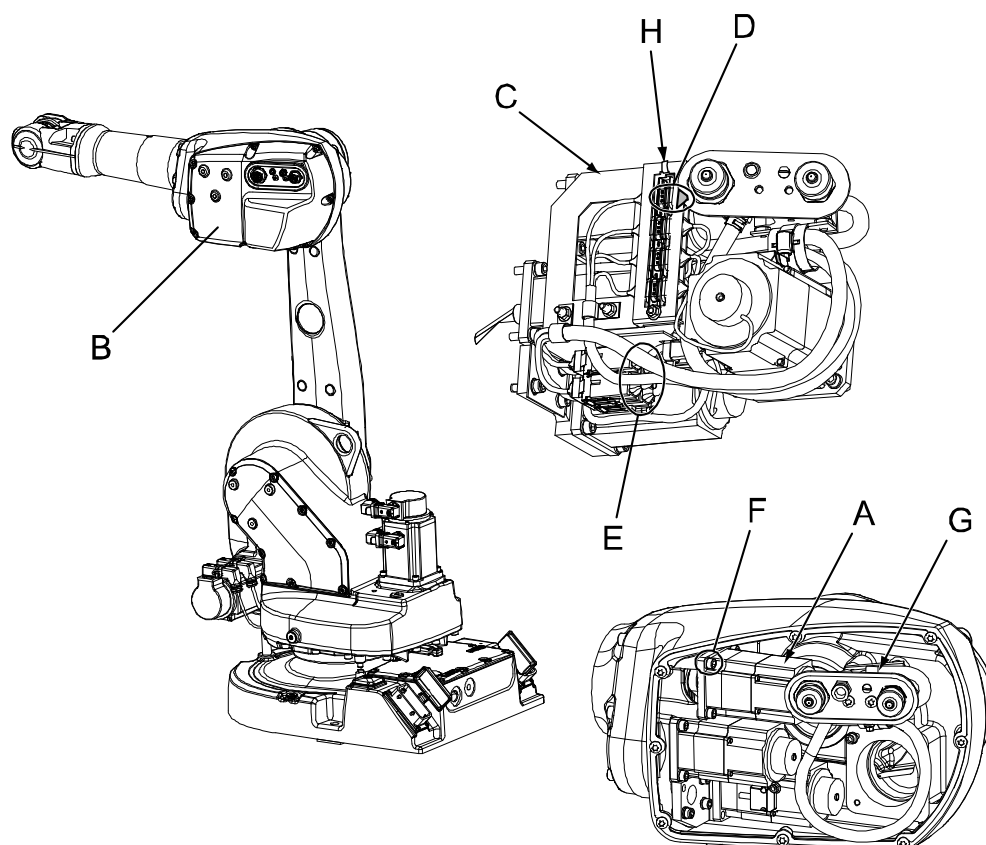

xx0400001281

A	Motor, axis 6
B	Cover, upper arm housing
C	Connector plate
D	Signal cable, axis 6 motor: R3.FB6
E	Power cable, axis 6 motor: R3.MP6
F	Attachment screws and washers, motor (3 pcs)
G	Distance console with cable bracket and contact panel
H	Cable tie

## Required equipment

Equipment	Spare part no.	Art. no.	Note
Rot. ac motor incl pinion	3HAC021800-003		

Continues on next page

## 4 Repair

### 4.6.10 Replacement of motor and timing belt, axis 6, IRB 1600

Continued

Equipment	Spare part no.	Art. no.	Note
Timing belt	3HAC6779-1		
Gasket, upper arm cover	3HAC022049-001		Replace if damaged.
Gasket, customer connections	3HAC022050-001		Replace if damaged.
Hook		3HAC024045-001	
Dynamometer		-	Capacity: 100N
Standard toolkit			Content is defined in section <a href="#">Standard tools on page 383</a> .
Other tools and procedures may be required. See references to these procedures in the step-by-step instructions below.			These procedures include references to the tools required.
Circuit diagram			See chapter <a href="#">Circuit diagram on page 389</a> .



#### CAUTION

Always cut the paint with a knife and grind the paint edge when disassembling parts. See [Cut the paint or surface on the robot before replacing parts on page 159](#).

#### Deciding calibration routine

Decide which calibration routine to be used, based on the information in the table. Depending on which routine is chosen, action might be required prior to beginning the repair work of the robot, see the table.

	Action	Note
1	Decide which calibration routine to use for calibrating the robot. <ul style="list-style-type: none"> <li>Reference calibration. External cable packages (DressPack) and tools can stay fitted on the robot.</li> <li>Fine calibration. All external cable packages (DressPack) and tools must be removed from the robot.</li> </ul>	
	<b>If the robot is to be calibrated with reference calibration:</b> Find previous reference values for the axis or create new reference values. These values are to be used after the repair procedure is completed, for calibration of the robot.  If no previous reference values exist, and no new reference values can be created, then reference calibration is not possible.	Follow the instructions given in the reference calibration routine on the FlexPendant to create reference values.  Creating new values requires possibility to move the robot.  Read more about reference calibration for Axis Calibration in <a href="#">Reference calibration routine on page 350</a> .  Read more about reference calibration for Pendulum Calibration in <a href="#">Operating manual - Calibration Pendulum</a> .
	<b>If the robot is to be calibrated with fine calibration:</b> Remove all external cable packages (DressPack) and tools from the robot.	

Continues on next page

**Removal, motor and timing belt, axis 6**

The procedure below details how to remove the motor and timing belt of axis 6.

	Action	Note
1	Decide which calibration routine to use, and take actions accordingly prior to beginning the repair procedure.	
2	 <b>DANGER</b> Turn off all: <ul style="list-style-type: none"> <li>• electric power supply</li> <li>• hydraulic pressure supply</li> <li>• air pressure supply</li> </ul> to the robot, before entering the robot working area.	
3	Remove the cover from the upper arm housing.	
4	Remove the <i>connector plate</i> .	Shown in the figure <a href="#">Location of motor on page 311</a> .
5	Remove the complete <i>distance console</i> with cable brackets and contact panel.	Shown in the figure <a href="#">Location of motor on page 311</a> .
6	Disconnect the motor cables for the axis 6 motor; R3.MP6 and R3.FB6.	
7	Remove the axis 6 motor by unscrewing its three attachment screws and washers.	
8	Remove the timing belt.	

**Refitting, motor and timing belt, axis 6**

The procedure below details how to refit the motor and timing belt of axis 6.



	Action	Note
1	Clean the mating surfaces on the motor and in the upper arm housing.	

Continues on next page

## 4 Repair

### 4.6.10 Replacement of motor and timing belt, axis 6, IRB 1600

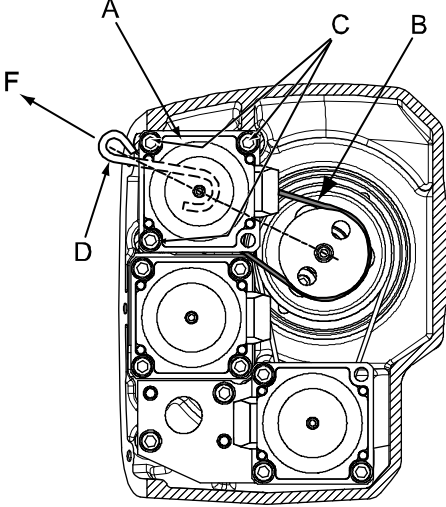
Continued

	Action	Note
2	<p>Follow the steps below when fitting the motor:</p> <ul style="list-style-type: none"> <li>Place the timing belt (B) round the motor pinion and place the belt round the axis 6 as fitting the motor in the upper arm housing.</li> <li>Secure the motor with its tree attachment screws and washers (C), but do not tighten them yet.</li> <li>Attach the <i>hook</i> round the motor pinion (underneath the motor) and adjust the belt tension with a force of 80 N, using a <i>dynamometer</i>. Shown in the figure to the right.</li> <li>Tighten the motor attachment screws with a torque of 10 Nm.</li> </ul>	 <p>xx0400001282</p> <ul style="list-style-type: none"> <li>A Motor, axis 6</li> <li>B Timing belt, axis 6</li> <li>C Attachment screws and washers, motor, 3 pcs, M6 x 20</li> <li>D Hook (motor pinion: Ø24.07 mm)</li> <li>F (Force): 80 N.</li> </ul>
3	Refit the complete <i>distance console</i> .	Shown in the figure <a href="#">Location of motor on page 311</a> .
4	Refit the <i>connector plate</i> . Refit the <i>cable tie</i> .	Shown in the figure <a href="#">Location of motor on page 311</a> .
5	Reconnect the motor cables: R3.MP6 and R3.FB6.	
6	Place all the cabling correctly inside the upper arm housing.	Cable layout is shown in the figure <a href="#">Illustration, cabling inside upper arm housing on page 166</a> .
7	Refit the cover to the upper arm housing. Check both the <i>gaskets</i> and replace, if damaged.	Art. no. is specified in <a href="#">Required equipment on page 311</a> .
8	Recalibrate the robot!	<p>Pendulum Calibration is described in <a href="#">Operating manual - Calibration Pendulum</a>, enclosed with the calibration tools.</p> <p>Axis Calibration is described in <a href="#">Calibrating with Axis Calibration method on page 349</a>.</p> <p>General calibration information is included in section <a href="#">Calibration on page 337</a>.</p>
9	 <p><b>DANGER</b></p> <p>Make sure all safety requirements are met when performing the first test run. These are further detailed in the section <a href="#">First test run may cause injury or damage on page 28</a>.</p>	

## 4.6.11 Replacement of motor, axis 6, IRB 1600ID

**Note**

After replacement of motors/motor in a manipulator, recalibration is required.

**Location of motor**

The motor of axis 6 is located inside the upper arm housing, as shown in the figure below.

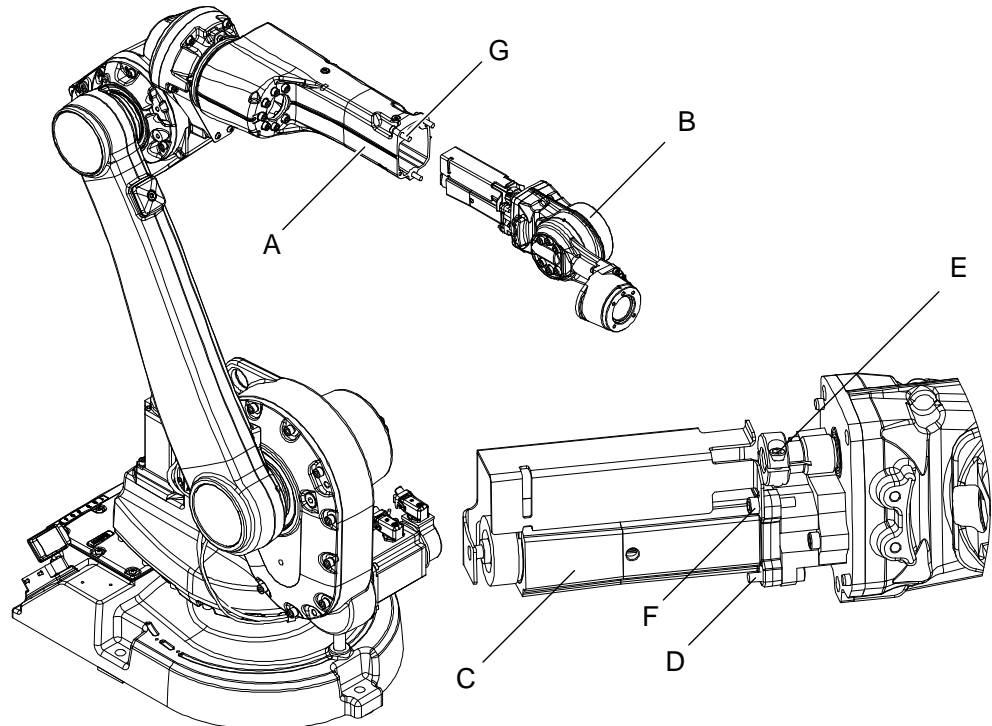

xx070000025

A	Upper arm
B	Wrist
C	Motor, axis 6
D	Hexagon socket head screw M5x25
E	Hexagon socket head screw M5x16 10.9 (Short head)
F	Hexagon socket head screw M5x25
G	Hexagon socket head screw M8x35

**Required equipment**

Equipment	Art. no.	Note
Rot. ac motor incl pinion	For spare part number, see: <ul style="list-style-type: none"> <li><a href="#">Spare part lists on page 387</a></li> </ul>	

*Continues on next page*

## 4 Repair

### 4.6.11 Replacement of motor, axis 6, IRB 1600ID

Continued

Equipment	Art. no.	Note
Standard toolkit	-	<a href="#">Standard tools on page 383</a>
Other tools and procedures may be required. See references to these procedures in the step-by-step instructions below.		These procedures include references to the tools required.
Circuit diagram	-	See <a href="#">Circuit diagram on page 389</a> .



#### CAUTION

Always cut the paint with a knife and grind the paint edge when disassembling parts. See [Cut the paint or surface on the robot before replacing parts on page 159](#).

#### Deciding calibration routine

Decide which calibration routine to be used, based on the information in the table. Depending on which routine is chosen, action might be required prior to beginning the repair work of the robot, see the table.



	Action	Note
1	Decide which calibration routine to use for calibrating the robot. <ul style="list-style-type: none"> <li>Reference calibration. External cable packages (DressPack) and tools can stay fitted on the robot.</li> <li>Fine calibration. All external cable packages (DressPack) and tools must be removed from the robot.</li> </ul>	
	<b>If the robot is to be calibrated with reference calibration:</b> Find previous reference values for the axis or create new reference values. These values are to be used after the repair procedure is completed, for calibration of the robot. If no previous reference values exist, and no new reference values can be created, then reference calibration is not possible.	Follow the instructions given in the reference calibration routine on the FlexPendant to create reference values. Creating new values requires possibility to move the robot. Read more about reference calibration for Axis Calibration in <a href="#">Reference calibration routine on page 350</a> . Read more about reference calibration for Pendulum Calibration in <i>Operating manual - Calibration Pendulum</i> .
	<b>If the robot is to be calibrated with fine calibration:</b> Remove all external cable packages (DressPack) and tools from the robot.	

#### Removal of motor axis 6

	Action	Note
1	Move the upper arm to the synchronization position.	
2	Decide which calibration routine to use, and take actions accordingly prior to beginning the repair procedure.	

Continues on next page



	Action	Note
3	 <b>DANGER</b> Turn off all: <ul style="list-style-type: none"> <li>• electric power supply</li> <li>• hydraulic pressure supply</li> <li>• air pressure supply</li> </ul> to the robot, before entering the robot working area.	
4	Remove all extra equipment fitted on the upper arm and wrist.	See <a href="#">Remove AW Gun on page 229</a>
5	Remove the wrist.  <b>CAUTION</b> Be careful when handling the wrist. Always hold on the casting, do not hold on the wrist cover. This can damage the sealing which will cause oil leakage.	See <a href="#">Removing the wrist unit on page 208</a>
6	Put the wrist on a work bench or similar.	
7	Remove the cable protection by removing the nuts that holds it.	
8	Open the flexible coupling of the axis-6 motor.	
9	Remove the attachment screws that holds the console and the axis-6 motor.	
10	Remove the motor.	

### Refitting of motor axis 6

	Action	Note
1	Remove the old console from the removed axis-6 motor, and scrap it.	
2	Remove the new console from the new spare part wrist.	
3	Fit the new console to the axis-6 motor.	Tightening torque: 6 Nm
4	Fit motor with the new console fitted to the new wrist.	Use Loctite 243 on the attachment screws.
5	Tighten the attachment screws just enough to still be able to move motor and console.	
6	Use caution and rotate the coupling manually. This will help the coupling and motor shaft to be aligned.	
7	Tighten the attachment screws that holds the console to the wrist.	Tightening torque: 6 Nm
8	Check wrist motion by rotating the coupling manually. The motion shall be smooth and even. If not unscrew the attachment screws that holds motor and console, and redo the process.	
9	Tighten the lock screw on the coupling.	Tightening torque: 6 Nm
10	Fit the cable protection cover.	Tightening torque: 6 Nm

Continues on next page

## 4 Repair

### 4.6.11 Replacement of motor, axis 6, IRB 1600ID

Continued

	Action	Note
11	Secure the cables to the attachment point with a cable strap.	
12	Refit the wrist.	
13	Recalibrate the robot!	<p>Pendulum Calibration is described in <i>Operating manual - Calibration Pendulum</i>, enclosed with the calibration tools.</p> <p>Axis Calibration is described in <a href="#">Calibrating with Axis Calibration method on page 349</a>.</p> <p>General calibration information is included in section <a href="#">Calibration on page 337</a>.</p>
14	 <b>DANGER</b>  Make sure all safety requirements are met when performing the first test run. These are further detailed in the section <a href="#">First test run may cause injury or damage on page 28</a> .	

## 4.6.12 Replacement of motor, axis 6, IRB 1660ID

**Note**

After replacement of motors/motor in a manipulator, recalibration is required.

**Location of motor axis 6**

Motor axis 6 is located inside the upper arm tube, as shown in the figure.

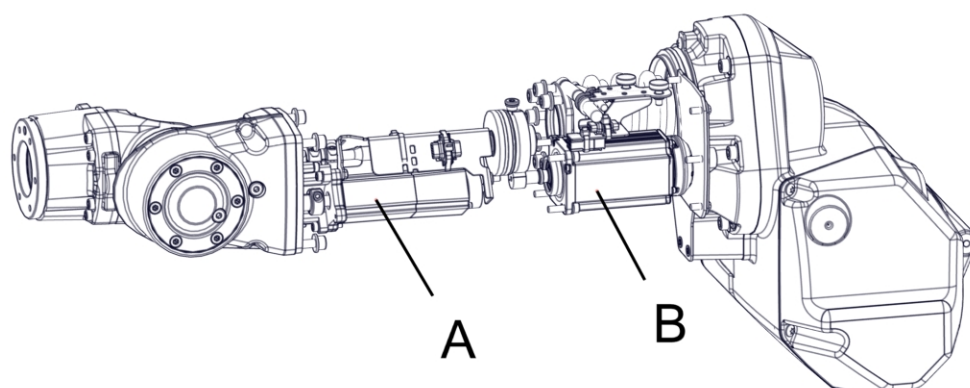

xx1500001258

A	Motor axis 6
B	Motor axis 5

**Required equipment**

Equipment	Art. no.	Note
Motor, axis 6	For spare part number, see: <ul style="list-style-type: none"> <li><a href="#">Spare part lists on page 387</a></li> </ul>	
Wrist unit, ID	For spare part number, see: <ul style="list-style-type: none"> <li><a href="#">Spare part lists on page 387</a></li> </ul>	
VK-cover	3HAA2166-18	Always replace with a new when removed.
Locking liquid	-	Loctite 574
Standard toolkit		Content is defined in section <a href="#">Standard tools on page 383</a> .
Other tools and procedures may be required. See references to these procedures in the step-by-step instructions below.		These procedures include references to the tools required.

**CAUTION**

Always cut the paint with a knife and grind the paint edge when disassembling parts. See [Cut the paint or surface on the robot before replacing parts on page 159](#).

*Continues on next page*

## 4 Repair

### 4.6.12 Replacement of motor, axis 6, IRB 1660ID

Continued

#### Deciding calibration routine

Decide which calibration routine to be used, based on the information in the table. Depending on which routine is chosen, action might be required prior to beginning the repair work of the robot, see the table.

	Action	Note
1	<p>Decide which calibration routine to use for calibrating the robot.</p> <ul style="list-style-type: none"> <li>Reference calibration. External cable packages (DressPack) and tools can stay fitted on the robot.</li> <li>Fine calibration. All external cable packages (DressPack) and tools must be removed from the robot.</li> </ul>	
	<p><b>If the robot is to be calibrated with reference calibration:</b></p> <p>Find previous reference values for the axis or create new reference values. These values are to be used after the repair procedure is completed, for calibration of the robot.</p> <p>If no previous reference values exist, and no new reference values can be created, then reference calibration is not possible.</p>	<p>Follow the instructions given in the reference calibration routine on the FlexPendant to create reference values.</p> <p>Creating new values requires possibility to move the robot.</p> <p>Read more about reference calibration for Axis Calibration in <a href="#">Reference calibration routine on page 350</a>.</p> <p>Read more about reference calibration for Pendulum Calibration in <i>Operating manual - Calibration Pendulum</i>.</p>
	<p><b>If the robot is to be calibrated with fine calibration:</b></p> <p>Remove all external cable packages (DressPack) and tools from the robot.</p>	

#### Removing axis-6 motor and wrist unit

Use this procedure to remove the axis-6 motor and the wrist unit.

	Action	Information
1	Decide which calibration routine to use, and take actions accordingly prior to beginning the repair procedure.	
2	Move the upper arm to synchronization position.	
3	 <p><b>DANGER</b></p> <p>Turn off all:</p> <ul style="list-style-type: none"> <li>electric power supply</li> <li>hydraulic pressure supply</li> <li>air pressure supply</li> </ul> <p>to the robot, before entering the robot working area.</p>	
4	Remove all extra equipment fitted on the upper arm.	

Continues on next page

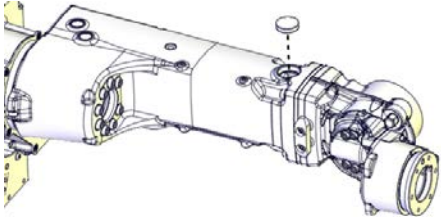
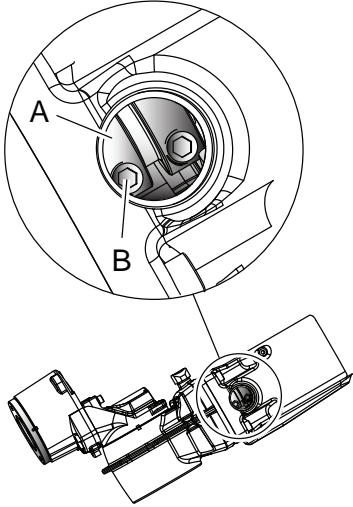
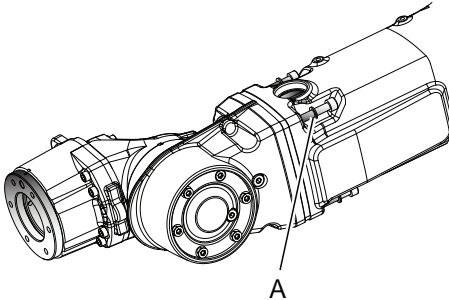

	Action	Information
5	Remove the VK-cover.	 <p>xx100000873</p>
6	Open the flexible coupling securing motor axis 5, on the side facing the wrist.	 <p>xx100000874</p> <ul style="list-style-type: none"> <li>• A: Coupling</li> <li>• B: Attachment screw</li> </ul>
7	Remove the attachment screws securing the wrist.	 <p>xx100000875</p> <ul style="list-style-type: none"> <li>• A: Attachment screws (4 pcs)</li> </ul>

Continues on next page

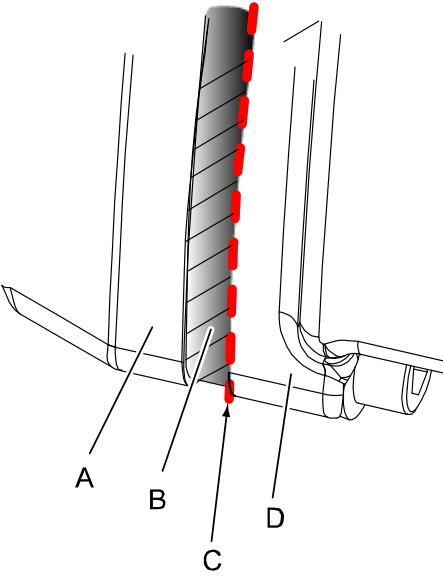

## 4 Repair

### 4.6.12 Replacement of motor, axis 6, IRB 1660ID

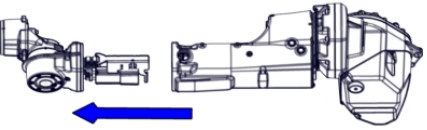
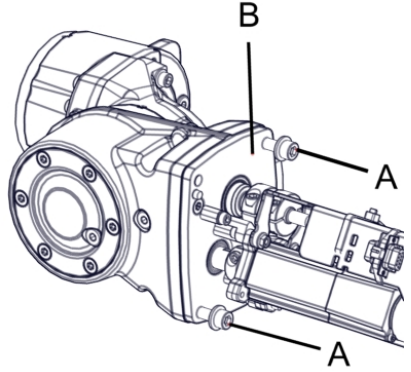
Continued

	Action	Information
8	<p>Separate wrist and upper arm tube at the marked division point (along the dotted line in the figure).</p> <p> <b>Note</b></p> <p>There is oil inside the wrist. The cover is only secured with Loctite 574. If opened in the wrong place oil will spill out.</p>	 <p>xx100000933</p> <ul style="list-style-type: none"> <li>• A: Wrist</li> <li>• B: Cover (Secured with Loctite 574 to the wrist)</li> <li>• C: Division point</li> <li>• D: Upper arm tube</li> </ul>
9	<p>Pull carefully out the wrist a little to reach the motor cables to motor axis 6.</p> <p> <b>Note</b></p> <p>The wrist is fitted on cylindrical pins.</p>	 <p>xx1500001259</p>
10	<p>Fit two short screws to the holes for the attachment screws to temporarily secure the cover.</p>	 <p>xx1500003257</p> <ul style="list-style-type: none"> <li>• A: Short screws (2 pcs)</li> <li>• B: Cover</li> </ul>

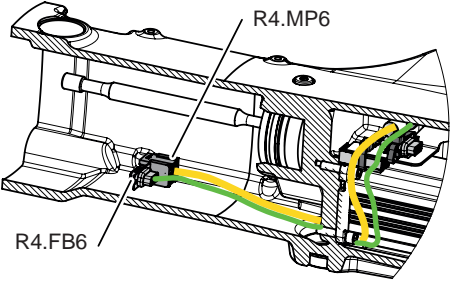
Continues on next page

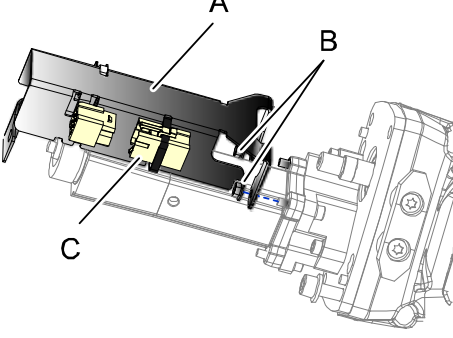
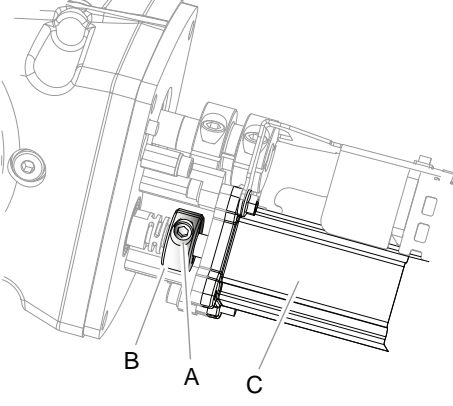
	Action	Information
11	Disconnect the cables R4.MP6 and R4.FB6 to motor axis 6.	 <p>xx1400002575</p>
12	Put the wrist with motor axis 6 on a work bench.	
13	 <b>Note</b> Do not move the gears in the wrist when the motor is removed! When refitting the motor the gears in the wrist shall be in the same position as they were before the removal.	
14	Remove the cable protection by removing the nuts securing it.	 <p>xx1000000931</p> <ul style="list-style-type: none"> <li>• A: Cable protection</li> <li>• B: Nuts (2 pcs)</li> <li>• C: Connector motor axis 6</li> </ul>
15	Open the flexible coupling securing motor axis 6.	 <p>xx1000000930</p> <ul style="list-style-type: none"> <li>• A: Attachment screw, coupling</li> <li>• B: Flexible coupling</li> <li>• C: Motor, axis 6</li> </ul>

Continues on next page

## 4 Repair

### 4.6.12 Replacement of motor, axis 6, IRB 1660ID

Continued

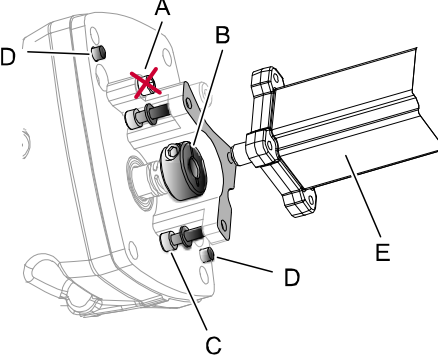
Action	Information
<p>16 Remove the attachment screws securing motor axis 6 and remove the motor.</p> <p> <b>Note</b></p> <p>Do not remove the attachment screws securing the motor bracket.</p>	 <p>xx100000929</p> <ul style="list-style-type: none"> <li>• A: Attachment screws, bracket</li> <li>• B: Flexible coupling</li> <li>• C: Attachment screws, motor (3 pcs)</li> <li>• D: Cylindrical pins (2 pcs)</li> <li>• E: Motor axis 6</li> </ul>

### Refitting axis-6 motor and wrist unit

Use this procedure to refit the axis-6 motor and the wrist unit.

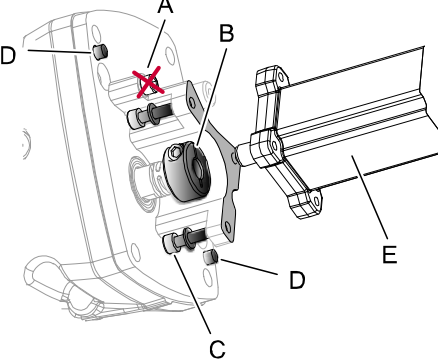
Action	Information
<p>1 Place the motor axis 6 into the flexible coupling axis 6.</p>	 <p>xx100000929</p> <ul style="list-style-type: none"> <li>• A: Attachment screws, bracket</li> <li>• B: Flexible coupling</li> <li>• C: Attachment screws, motor (3 pcs)</li> <li>• D: Cylindrical pins (2 pcs)</li> <li>• E: Motor axis 6</li> </ul>
<p>2 Secure the motor with its attachment screws.</p>	<p>Tightening torque: 6 Nm</p>

Continues on next page

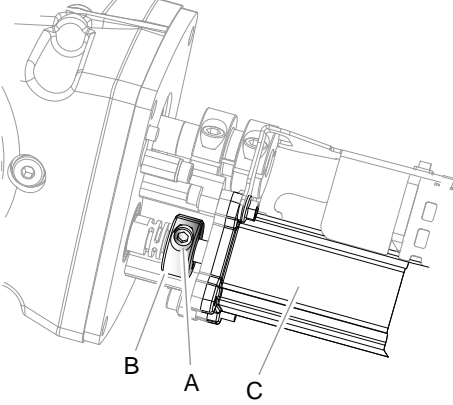
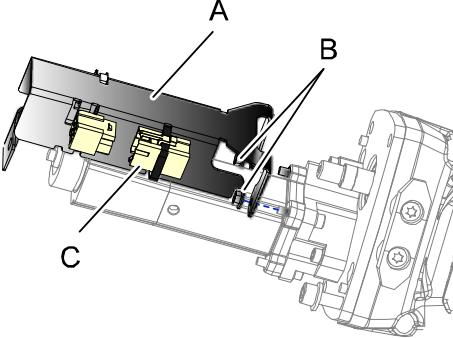
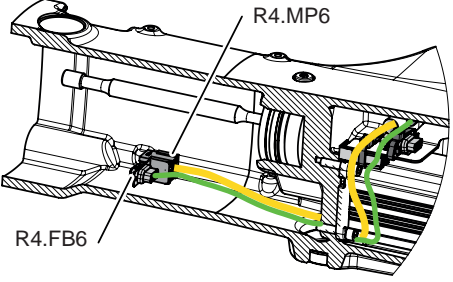

	Action	Information
3	Secure motor axis 6 with the flexible coupling with its attachment screw.	<p>Tightening torque: 15 Nm</p>  <p>xx1000000930</p> <ul style="list-style-type: none"> <li>• A: Attachment screw, coupling</li> <li>• B: Flexible coupling</li> <li>• C: Motor axis 6</li> </ul>
4	Fit the cable protection with its nuts.	 <p>xx1000000931</p> <ul style="list-style-type: none"> <li>• A: Cable protection</li> <li>• B: Nuts (2 pcs)</li> <li>• C: Connector motor axis 6</li> </ul>
5	Clean all assembly surfaces. Remove any painting from the assembly surfaces, with a knife.	
6	Place the wrist with motor axis 6 fitted a little into the upper arm tube.	
7	Reconnect the cables R4.MP6 and R4.FB6 to motor axis 6.	 <p>xx1400002575</p>

Continues on next page

## 4 Repair

### 4.6.12 Replacement of motor, axis 6, IRB 1660ID

Continued

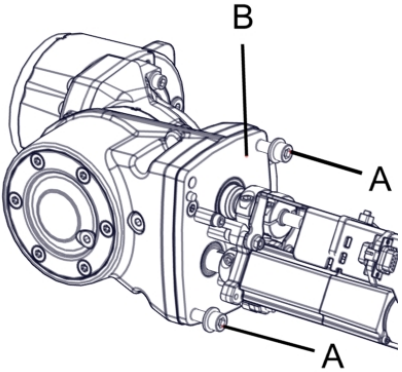
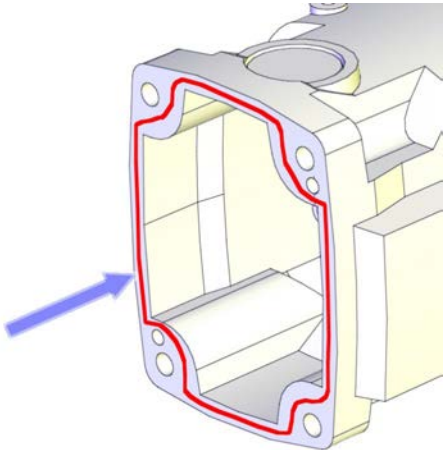
	Action	Information
8	Remove the two short screws used to temporarily secure the cover.	 <p>xx1500003257</p> <ul style="list-style-type: none"><li>• A: Short screws (2 pcs)</li><li>• B: Cover</li></ul>
9	Apply locking liquid to the assembly surface on the upper arm tube.	<p>The locking liquid is specified in <a href="#">Required equipment on page 319</a>.</p>  <p>xx1200000063</p>

Continues on next page

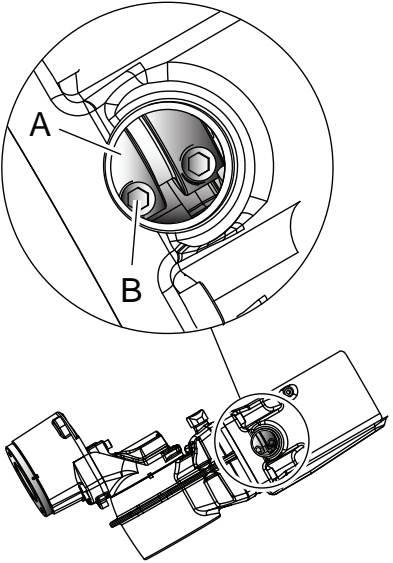
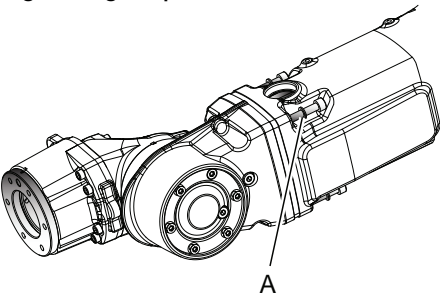
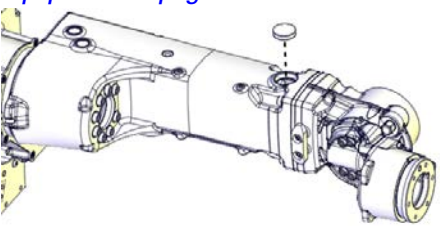
	Action	Information
10	<p>Push the wrist and motor axis 6 into its position onto the cylindrical pins.</p> <p> <b>Tip</b></p> <p>Look through the hole for the VK-cover when fitting the axis into the flexible coupling of motor axis 5.</p>	 <p>xx1000000874</p> <ul style="list-style-type: none"> <li>• A: Flexible coupling axis 5</li> <li>• B: Attachment screw</li> </ul>
11	<p>Secure the wrist with its attachment screws and washers.</p>	<p>Tightening torque: 35 Nm</p>  <p>xx1000000875</p> <ul style="list-style-type: none"> <li>• A: Attachment screws (4 pcs)</li> </ul>
12	<p>Secure the flexible coupling axis 5 with its attachment screw.</p>	<p>Tightening torque: 14 Nm</p>
13	<p>Fit a new VK-cover.</p>	<p>Article number is specified in <a href="#">Required equipment on page 319</a>.</p>  <p>xx1000000873</p>

Continues on next page

## 4 Repair

### 4.6.12 Replacement of motor, axis 6, IRB 1660ID

*Continued*

	Action	Information
14	Recalibrate the robot.	Pendulum Calibration is described in <i>Operating manual - Calibration Pendulum</i> , enclosed with the calibration tools. Axis Calibration is described in <a href="#">Calibrating with Axis Calibration method on page 349</a> . General calibration information is included in section <a href="#">Calibration on page 337</a> .
15	 <b>DANGER</b> Make sure all safety requirements are met when performing the first test run. These are further detailed in the section <a href="#">First test run may cause injury or damage on page 28</a> .	

## 4.7 Gearboxes

### 4.7.1 Replacement of gearbox, axes 1-2

#### Location of gearbox unit, axes 1-2

The gearboxes of axes 1 and 2 are located as shown in the figure below. Note that both gearboxes, 1 and 2, are a single unit!

A more detailed view of the gearbox and its position may be found in the spare part view, *Spare parts - Frame, exploded view*.

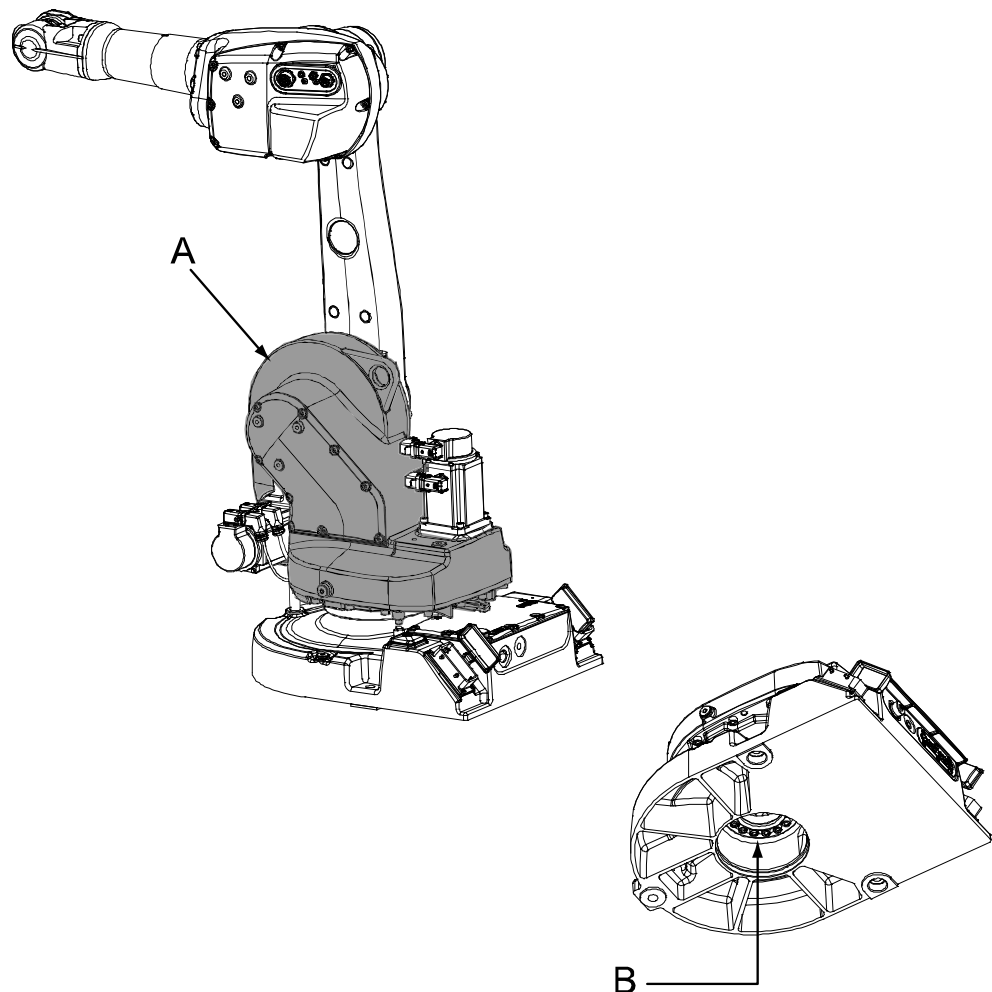

xx0500001400

A	Gearbox unit, axes 1-2
B	Attachment screws and washer, base-gearbox unit (VK-cover is removed)

*Continues on next page*

## 4 Repair

### 4.7.1 Replacement of gearbox, axes 1-2

Continued

#### Required equipment

Equipment	Art. no.	Note
Gearbox, axis 1 and 2	For spare part number, see: <ul style="list-style-type: none"> <li>• <a href="#">Spare part lists on page 387.</a></li> </ul>	Includes: <ul style="list-style-type: none"> <li>• gearbox</li> <li>• V-ring (sealing ring)</li> <li>• lubricating oil in vessel</li> <li>• stop arm</li> </ul>
VK-cover	3HAA2166-26	
Isopropanol	-	For cleaning the mating surfaces before fitting.
Grease	3HAB3537-1	For lubricating the V-ring.
Locking liquid	-	Loctite 574
Lifting slings	-	
Standard toolkit		Content is defined in section <a href="#">Standard tools on page 383.</a>
Other tools and procedures may be required. See references to these procedures in the step-by-step instructions below.		These procedures include references to the tools required.

#### Deciding calibration routine

Decide which calibration routine to be used, based on the information in the table. Depending on which routine is chosen, action might be required prior to beginning the repair work of the robot, see the table.

	Action	Note
1	Decide which calibration routine to use for calibrating the robot. <ul style="list-style-type: none"> <li>• Reference calibration. External cable packages (DressPack) and tools can stay fitted on the robot.</li> <li>• Fine calibration. All external cable packages (DressPack) and tools must be removed from the robot.</li> </ul>	
	<p><b>If the robot is to be calibrated with reference calibration:</b></p> <p>Find previous reference values for the axis or create new reference values. These values are to be used after the repair procedure is completed, for calibration of the robot.</p> <p>If no previous reference values exist, and no new reference values can be created, then reference calibration is not possible.</p>	<p>Follow the instructions given in the reference calibration routine on the FlexPendant to create reference values.</p> <p>Creating new values requires possibility to move the robot.</p> <p>Read more about reference calibration for Axis Calibration in <a href="#">Reference calibration routine on page 350.</a></p> <p>Read more about reference calibration for Pendulum Calibration in <i>Operating manual - Calibration Pendulum.</i></p>
	<p><b>If the robot is to be calibrated with fine calibration:</b></p> <p>Remove all external cable packages (DressPack) and tools from the robot.</p>	

Continues on next page





**CAUTION**

Always cut the paint with a knife and grind the paint edge when disassembling parts. See [Cut the paint or surface on the robot before replacing parts on page 159](#).

**Removal, gearbox unit axes 1-2**

The procedure below details how to remove the complete gearbox unit, axes 1-2.

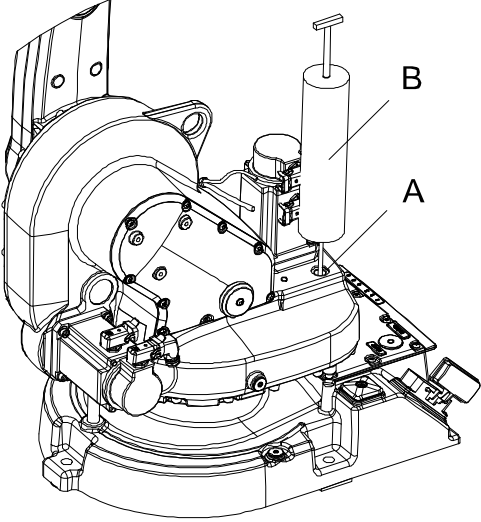

	Action	Note
1	Decide which calibration routine to use, and take actions accordingly prior to beginning the repair procedure.	
2	 <p><b>DANGER</b></p> <p>Turn off all:</p> <ul style="list-style-type: none"> <li>• electric power supply</li> <li>• hydraulic pressure supply</li> <li>• air pressure supply</li> </ul> <p>to the robot, before entering the robot working area.</p>	
3	 <p><b>CAUTION</b></p> <p>Always cut the paint with a knife and grind the paint edge when disassembling parts. See <a href="#">Cut the paint or surface on the robot before replacing parts on page 159</a>.</p>	
4	Remove the oil plug and drain all oil from gearbox axis 1 using a drain pump.	 <p>xx080000260</p> <p>A Oil plug B Drain pump</p>

Continues on next page

## 4 Repair

### 4.7.1 Replacement of gearbox, axes 1-2

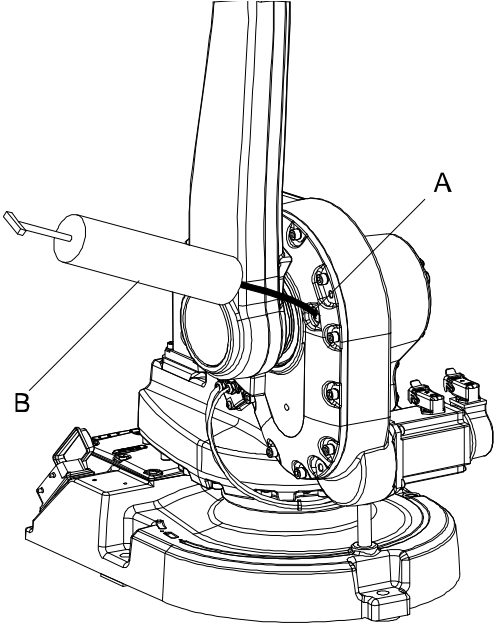
Continued

	Action	Note
5	Remove the oil plug and drain all oil from gearbox axis 2 using a drain pump.	 <p>xx0800000261</p> <p>A Oil plug B Drain pump</p>
6	Remove the motor, axis 2.	Detailed in section <a href="#">Replacement of motor, axis 2 on page 262</a> .
7	Remove the motor, axis 1.	Detailed in section <a href="#">Removing the motor axis 1 on page 259</a> .
8	Remove the complete arm system.	Detailed in section <a href="#">Removing the complete arm system on page 179</a> .
9	Unfasten the base from the installation site by removing the attachment bolts from the foundation.	
10	 <b>CAUTION</b> The gearbox unit weighs 120 kg. The base weighs 81 kg. All lifting accessories used must be sized accordingly!	
11	Fit the lifting slings to the base/gearbox unit and place it with the lower arm side downwards, on top of a suitable workbench.	
12	Remove the VK-cover from the bottom of the robot base. <b>Tip!</b> When the cabling is removed, it may be easier to drill a hole through the cover or to try and push it out from the inside.	
13	Secure the weight of the base with lifting slings.	



Continues on next page



	Action	Note
14	Remove the <i>gearbox/base attachment screws and washer</i> .	Shown in the figure <a href="#">Location of gearbox unit, axes 1-2 on page 329</a> .
15	Separate the base from the gearbox unit.	

## Refitting, gearbox unit axes 1-2

The procedure below details how to refit the complete gearbox unit, axes 1-2.



	Action	Note
1	 <b>Note</b> It is important that the gearbox and the mating motor pinion are provided by the same sub-supplier, make sure to order the correct spare part! To determine the correct spare part, see <i>Compatible gearboxes and motors</i> in <i>Product manual, spare parts - IRB 1600/1660</i> .	
2	 <b>DANGER</b> Turn off all: <ul style="list-style-type: none"> <li>• electric power supply</li> <li>• hydraulic pressure supply</li> <li>• air pressure supply</li> </ul> to the robot, before entering the robot working area.	
3	 <b>CAUTION</b> The gearbox unit weighs 120 kg. All lifting accessories used must be sized accordingly!	
4	Clean the joints that have been opened. See <a href="#">Cut the paint or surface on the robot before replacing parts on page 159</a>	
5	Place the gearbox unit with the lower arm side downwards on a suitable workbench.	
6	Clean the mating surfaces of the base and of the gearbox unit with isopropanol.	
7	Lubricate the V-ring with <i>grease</i> and fit it to the gearbox unit.	Art. no. is specified in <a href="#">Required equipment on page 330</a> .
8	Fit a small amount of Loctite 574 on the mating surface in the gearbox unit.	
9	Fit the base to the gearbox unit and secure it with the <i>attachment screws</i> and the washer.	Shown in the figure <a href="#">Location of gearbox unit, axes 1-2 on page 329</a> . 16 pcs, M10 x 40, tightening torque: 70 Nm.

Continues on next page

## 4 Repair

### 4.7.1 Replacement of gearbox, axes 1-2

Continued

	Action	Note
10	Fit a new VK-cover to the base of the robot.	Shown in the figure <a href="#">Location of gearbox unit, axes 1-2 on page 329</a> . Spare part no. is specified in <a href="#">Required equipment on page 330</a> .
11	 <b>CAUTION</b> The gearbox unit weighs 120 kg. The base weighs 81 kg. All lifting accessories used must be sized accordingly!	
12	Fit the <i>lifting slings</i> to the base/gearbox unit, turn it right side up and move it to the installation site.	
13	Secure the base to the foundation.	Attachment bolts and the tightening torque are specified in section <a href="#">Attachment bolts, specification on page 69</a> .
14	Refit the complete arm system.	Detailed in section <a href="#">Refitting, complete arm system on page 181</a> .
15	Refit the motors, axes 1 and 2.	Detailed in sections: <ul style="list-style-type: none"> <li>• <a href="#">Refitting the motor axis 1 on page 259</a></li> <li>• <a href="#">Refitting, motor axis 2 on page 265</a>.</li> </ul>
16	Perform a leak-down test.	Detailed in section <a href="#">Performing a leak-down test on page 154</a> .
17	Fill the two gearboxes with oil.	See, <i>Technical reference manual - Lubrication in gearboxes</i> .
18	Seal and paint the joints that have been opened. See <a href="#">Cut the paint or surface on the robot before replacing parts on page 159</a>   <b>Note</b> After all repair work, wipe the robot free from particles with spirit on a lint free cloth.	
19	Recalibrate the robot.	Pendulum Calibration is described in <i>Operating manual - Calibration Pendulum</i> , enclosed with the calibration tools. Axis Calibration is described in <a href="#">Calibrating with Axis Calibration method on page 349</a> . General calibration information is included in section <a href="#">Calibration on page 337</a> .
20	 <b>DANGER</b> Make sure all safety requirements are met when performing the first test run. These are further detailed in the section <a href="#">First test run may cause injury or damage on page 28</a> .	

#### 4.7.2 Service work on gearboxes, axes 3, 4, 5 and 6

---

##### Gearboxes, replacement

The gearboxes of axes 3, 4, 5 and 6 are intended to run without requiring any repairs or maintenance work. This implies that they must under *no circumstances* be opened or serviced.

If the gearboxes require replacement:

- axes 3 and 4: the complete upper arm is to be replaced. This procedure is detailed in section [Replacing the complete upper arm, IRB 1600 on page 183](#).
- axes 5 and 6: the complete wrist unit is to be replaced. This procedure is detailed in section [Replacing the wrist unit, IRB 1600 on page 201](#).

**This page is intentionally left blank**

## 5 Calibration

### 5.1 Introduction to calibration

#### 5.1.1 Introduction and calibration terminology

##### Calibration information

This chapter includes general information about the recommended calibration methods and also the detailed procedures for updating the revolution counters, checking the calibration position etc.

Detailed instructions of how to perform Axis Calibration are given on the FlexPendant during the calibration procedure. To prepare calibration with Axis Calibration method, see [Calibrating with Axis Calibration method on page 349](#).

Detailed instructions of how to perform Pendulum Calibration are given in the documentation enclosed with the calibration tools.

##### Calibration terminology

Term	Definition
Calibration method	A collective term for several methods that might be available for calibrating the ABB robot. Each method contains calibration routines.
Synchronization position	Known position of the complete robot where the angle of each axis can be checked against visual synchronization marks.
Calibration position	Known position of the complete robot that is used for calibration of the robot.
Standard calibration	A generic term for all calibration methods that aim to move the robot to calibration position.
Fine calibration	A calibration routine that generates a new zero position of the robot.
Reference calibration	<p>A calibration routine that in the first step generates a reference to current zero position of the robot. The same calibration routine can later on be used to recalibrate the robot back to the same position as when the reference was stored.</p> <p>This routine is more flexible compared to fine calibration and is used when tools and process equipment are installed.</p> <p>Requires that a reference is created before being used for recalibrating the robot.</p> <p>Requires that the robot is dressed with the same tools and process equipment during calibration as during creation of the reference values.</p>
Update revolution counter	A calibration routine to make a rough calibration of each manipulator axis.
Synchronization mark	Visual marks on the robot axes. When marks are aligned, the robot is in synchronization position.

## 5 Calibration

### 5.1.2 Calibration methods

### 5.1.2 Calibration methods

#### Overview

This section specifies the different types of calibration and the calibration methods that are supplied by ABB.

#### Types of calibration

Type of calibration	Description	Calibration method
Standard calibration	<p>The calibrated robot is positioned at calibration position.</p> <p>Standard calibration data is found on the SMB (serial measurement board) or EIB in the robot.</p> <p>For robots with RobotWare 5.04 or older, the calibration data is delivered in a file, <code>calib.cfg</code>, supplied with the robot at delivery. The file identifies the correct resolver/motor position corresponding to the robot home position.</p>	Axis Calibration or Calibration Pendulum <sup>i</sup>
Absolute accuracy calibration (optional)	<p>Based on standard calibration, and besides positioning the robot at synchronization position, the Absolute accuracy calibration also compensates for:</p> <ul style="list-style-type: none"> <li>• Mechanical tolerances in the robot structure</li> <li>• Deflection due to load</li> </ul> <p>Absolute accuracy calibration focuses on positioning accuracy in the Cartesian coordinate system for the robot.</p> <p>Absolute accuracy calibration data is found on the SMB (serial measurement board) in the robot.</p> <p>For robots with RobotWare 5.05 or older, the absolute accuracy calibration data is delivered in a file, <code>absacc.cfg</code>, supplied with the robot at delivery. The file replaces the <code>calib.cfg</code> file and identifies motor positions as well as absolute accuracy compensation parameters.</p> <p>A robot calibrated with absolute accuracy has a sticker next to the identification plate of the robot.</p> <p>To regain 100% absolute accuracy performance, the robot must be recalibrated for absolute accuracy!</p> <div style="border: 1px solid black; padding: 5px; width: fit-content;">  <p style="text-align: center; margin: 0;"><b>ABSOLUTE ACCURACY</b></p> <p style="text-align: right; font-size: small; margin: 0;">3HAC 14257-1</p> </div> <p style="font-size: x-small; margin-top: 5px;">xx0400001197</p>	CalibWare

<sup>i</sup> The robot is calibrated by either Calibration Pendulum or Axis Calibration at factory. Always use the same calibration method as used at the factory.  
 Information about valid calibration method is found on the calibration label or in the calibration menu on the FlexPendant.  
 If no data is found related to standard calibration, Calibration Pendulum is used as default.

*Continues on next page*

---

#### Brief description of calibration methods

##### Calibration Pendulum method

Calibration Pendulum is a standard calibration method for calibration of all ABB robots (except IRB 6400R, IRB 640, IRB 1400H, and IRB 4400S).

Two different routines are available for the Calibration Pendulum method:

- Calibration Pendulum II
- Reference calibration

The calibration equipment for Calibration Pendulum is delivered as a complete toolkit, including the *Operating manual - Calibration Pendulum*, which describes the method and the different routines further.

##### Axis Calibration method

Axis Calibration is a standard calibration method for calibration of IRB 1600/1660ID and is the most accurate method for the standard calibration. It is the recommended method in order to achieve proper performance.

The following routines are available for the Axis Calibration method:

- Fine calibration
- Update revolution counters
- Reference calibration

The calibration equipment for Axis Calibration is delivered as a toolkit.

An introduction to the calibration method is given in this manual, see [Calibrating with Axis Calibration method on page 349](#).

The actual instructions of how to perform the calibration procedure and what to do at each step is given on the FlexPendant. You will be guided through the calibration procedure, step by step.

##### CalibWare - Absolute Accuracy calibration

To achieve a good positioning in the Cartesian coordinate system, Absolute Accuracy calibration is used as a TCP calibration. The CalibWare tool guides through the calibration process and calculates new compensation parameters. This is further detailed in the *Application manual - CalibWare Field 5.0*.

If a service operation is done to a robot with the option Absolute Accuracy, a new absolute accuracy calibration is required in order to establish full performance. For most cases after motor and transmission replacements that do not include taking apart the robot structure, standard calibration is sufficient. Standard calibration also supports wrist exchange.

---

#### References

Article numbers for the calibration tools are listed in the section [Special tools on page 384](#).

The calibration equipment for Calibration Pendulum is delivered as a complete toolkit, including the *Operating manual - Calibration Pendulum*, which describes the method and the different routines further.

## 5 Calibration

---

### 5.1.3 When to calibrate

### 5.1.3 When to calibrate

---

#### When to calibrate

The system must be calibrated if any of the following situations occur.

#### The resolver values are changed

If resolver values are changed, the robot must be recalibrated using the calibration methods supplied by ABB. Calibrate the robot carefully with standard calibration, according to information in this manual.

If the robot has *absolute accuracy* calibration, it is also recommended, but not always necessary to calibrate for new absolute accuracy.

The resolver values will change when parts affecting the calibration position are replaced on the robot, for example motors or parts of the transmission.

#### The revolution counter memory is lost

If the revolution counter memory is lost, the counters must be updated. See [Updating revolution counters on page 345](#). This will occur when:

- The battery is discharged
- A resolver error occurs
- The signal between a resolver and measurement board is interrupted
- A robot axis is moved with the control system disconnected

The revolution counters must also be updated after the robot and controller are connected at the first installation.

#### The robot is rebuilt

If the robot is rebuilt, for example, after a crash or when the reach ability of a robot is changed, it needs to be recalibrated for new resolver values.

If the robot has *absolute accuracy* calibration, it needs to be calibrated for new absolute accuracy.



## 5.2 Synchronization marks and axis movement directions

### 5.2.1 Synchronization marks and synchronization position for axes

#### Introduction

This section shows the position of the synchronization marks and the synchronization position for each axis.

#### Synchronization marks, IRB 1600/IRB 1660ID

##### IRB 1600

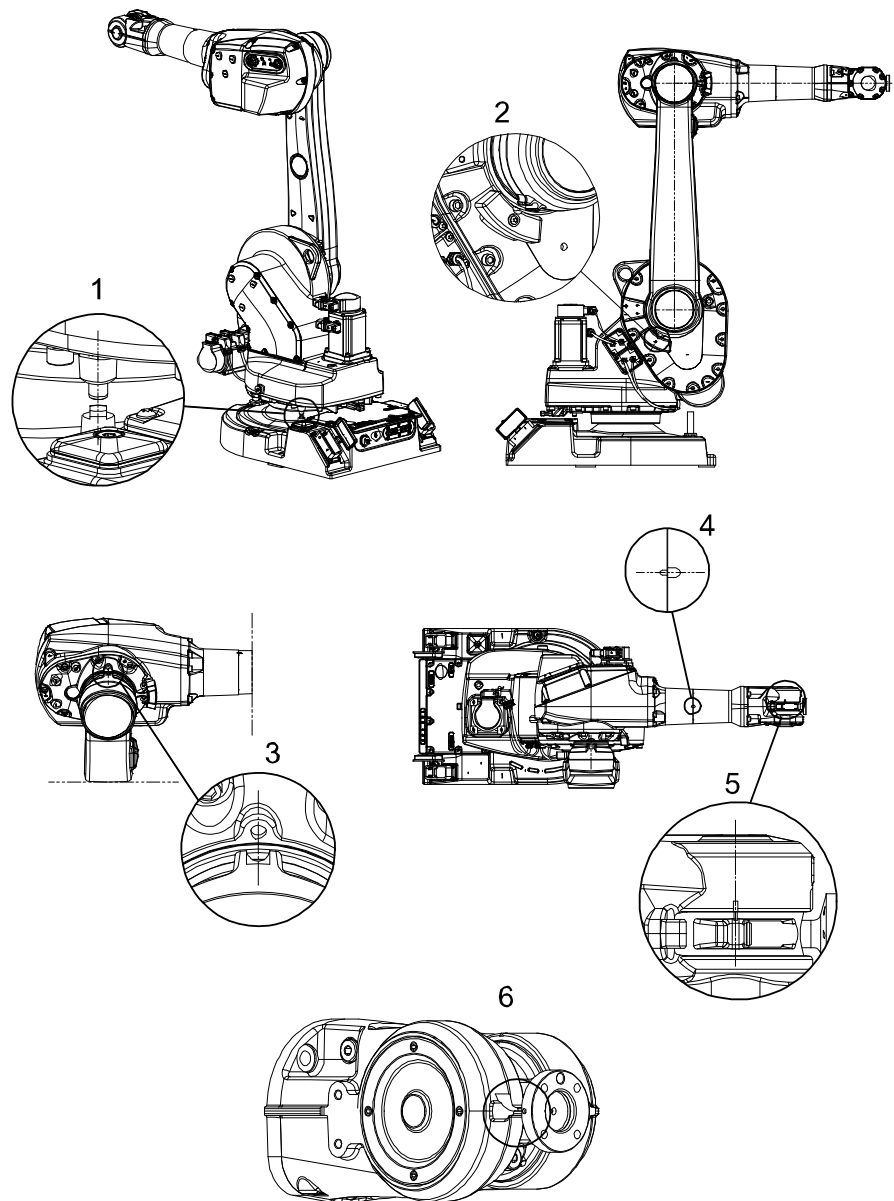

xx0600002876

*Continues on next page*

## 5 Calibration

### 5.2.1 Synchronization marks and synchronization position for axes

*Continued*

#### IRB 1600ID

The illustration shows the synchronization marks of axes 4, 5 and 6 for IRB 1600ID. Refer to illustration valid for IRB 1600 for axes 1, 2 and 3.

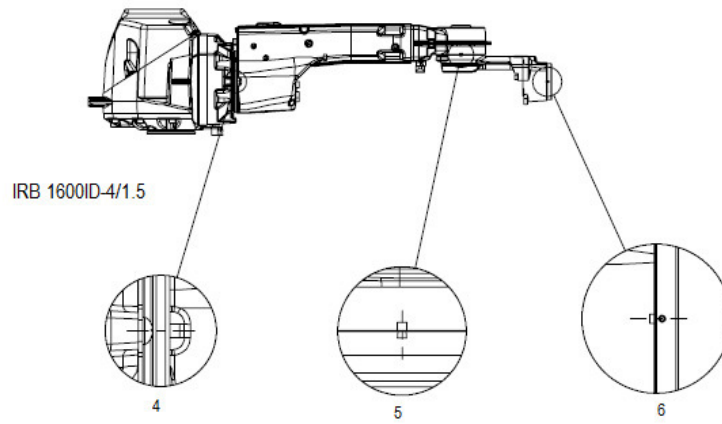

xx1500001256

#### IRB 1660ID

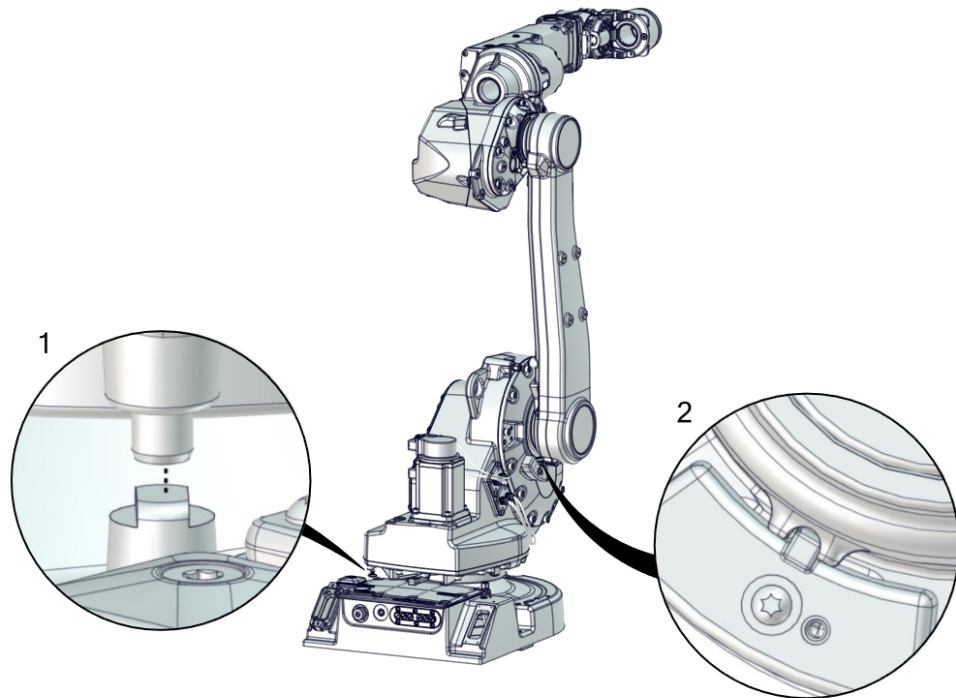

xx170000115

*Continues on next page*

5.2.1 Synchronization marks and synchronization position for axes

*Continued*

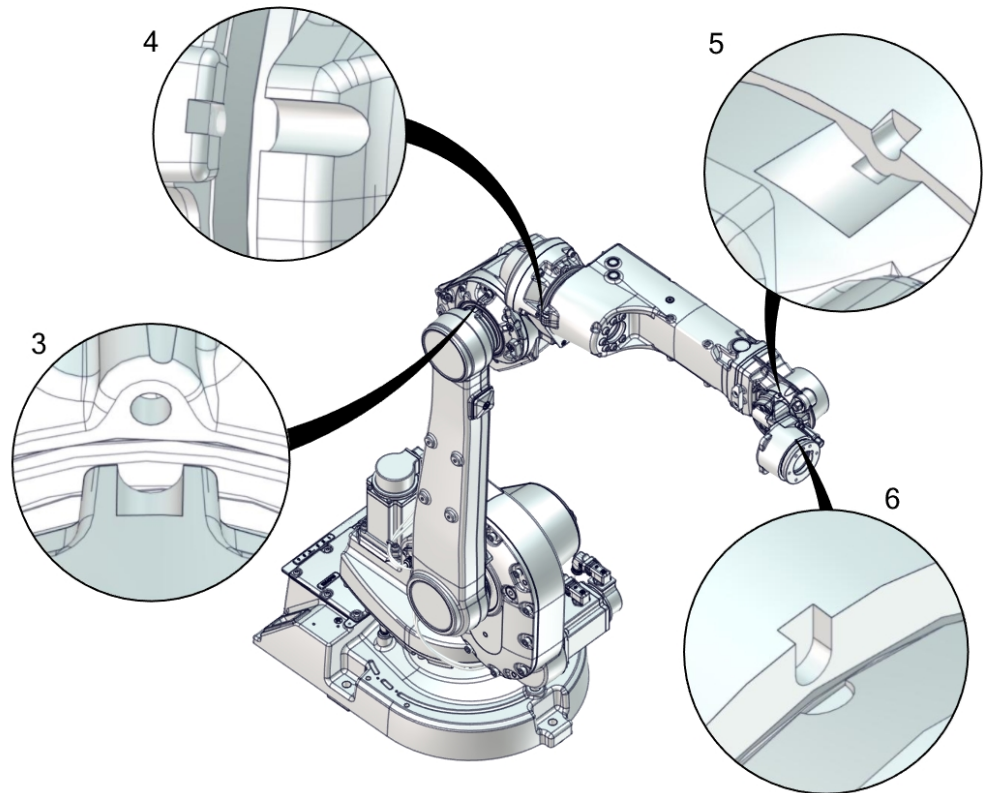

xx170000116

## 5 Calibration

### 5.2.2 Calibration movement directions for all axes

### 5.2.2 Calibration movement directions for all axes

#### Overview

When calibrating, the axis must consistently be run towards the calibration position in the same direction in order to avoid position errors caused by backlash in gears and so on. Positive directions are shown in the graphic below.

Calibration service routines will handle the calibration movements automatically and these might be different from the positive directions shown below.

#### Manual movement directions, 6 axes

**Note!** The graphic shows an IRB 7600. The positive direction is the same for all 6-axis robots, except the positive direction of axis 3 for IRB 6400R, which is in the opposite direction!

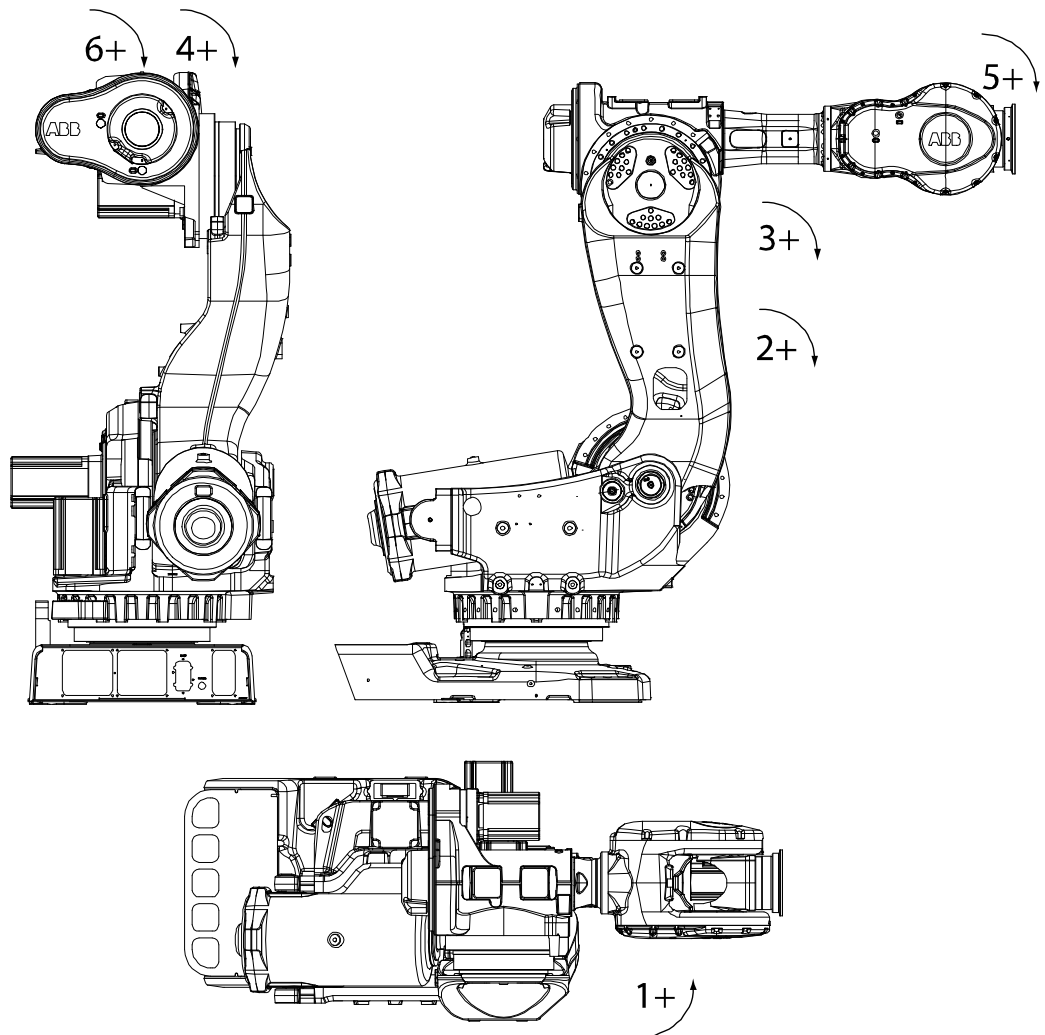

xx020000089

## 5.3 Updating revolution counters

### Introduction

This section describes how to do a rough calibration of each manipulator axis by updating the revolution counter for each axis, using the FlexPendant.

### Coupled axes

When updating the revolution counters for a coupled axis, also the axis it is coupled to needs to be at its synchronization position for the update to be correct; i.e. axis 4 needs to be in synchronization position when updating axis 5 and 6.

With reversed coupled joints, the relationship is the opposite, i.e. axis 4 needs to be in synchronization position to update axis 3.

Coupled axes	IRB 140	IRB 1410	IRB 1520	IRB 1600	IRB 1600ID	IRB 1660ID	IRB 910 SC	IRB 2400	IRB 2600	IRB 2600ID	IRB 4400	IRB 4450S	IRB 4600
Axis 4, 5, 6	x			x				x	x		x	x	x
Axis 5, 6		x	x		x	x				x			
Axis 4, 3							x						

### Step 1 - Manually running the manipulator to the synchronization position

Use this procedure to manually run the manipulator to the synchronization position.

	Action	Note
1	Select axis-by-axis motion mode.	
2	Jog the manipulator to align the synchronization marks.	See <a href="#">Synchronization marks and synchronization position for axes on page 341</a> .
3	When all axes are positioned, update the revolution counter.	<a href="#">Step 2 - Updating the revolution counter with the FlexPendant on page 346</a> .

### Correct calibration position of axis 4 and 6

When jogging the manipulator to synchronization position, it is extremely important to make sure that axes 4 and 6 of the following mentioned manipulators are positioned correctly. The axes can be calibrated at the wrong turn, resulting in an incorrect manipulator calibration.

Make sure the axes are positioned according to the correct calibration values, not only according to the synchronization marks. The correct values are found on a label, located either on the lower arm, underneath the flange plate on the base or on the frame.

At delivery the manipulator is in the correct position, do NOT rotate axis 4 or 6 at power up before the revolution counters are updated.

*Continues on next page*

## 5 Calibration

### 5.3 Updating revolution counters

*Continued*

If one of the following mentioned axes are rotated one or more turns from its calibration position before updating the revolution counter, the correct calibration position will be lost due to non-integer gear ratio. This affects the following manipulators:

Manipulator variant	Axis 4	Axis 6
IRB 1600	No	Yes
IRB 1600ID	No	No

If the synchronization marks seem to be wrong (even if the motor calibration data is correct), try to rotate the axis one turn, update the revolution counter and check the synchronization marks again (try both directions, if needed).

#### Step 2 - Updating the revolution counter with the FlexPendant

Use this procedure to update the revolution counter with the FlexPendant (IRC5).

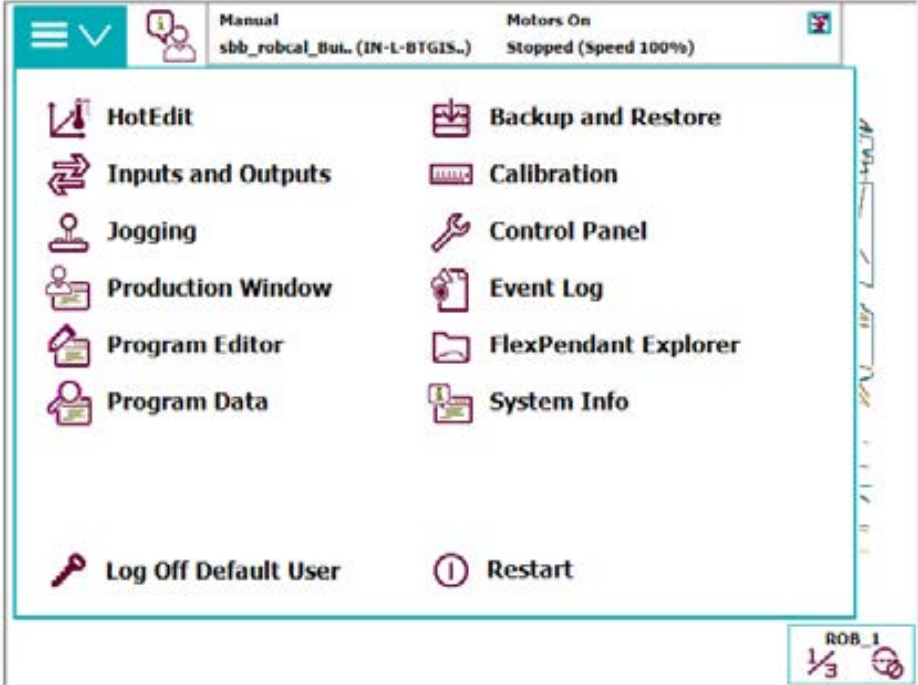
Action
<p>1 On the <b>ABB</b> menu, tap <b>Calibration</b>.</p>  <p>The screenshot shows the ABB FlexPendant menu interface. At the top, it displays 'Manual sbb_robcal_But. (IN-L-BYGIS...)' and 'Motors On Stopped (Speed 100%)'. The main menu contains several options: HotEdit, Backup and Restore, Inputs and Outputs, Calibration (highlighted with a red box), Control Panel, Jogging, Event Log, Production Window, FlexPendant Explorer, Program Editor, System Info, Program Data, Log Off Default User, and Restart. A 'ROB_1' status indicator is visible in the bottom right corner.</p> <p>xx1500000942</p>

*Continues on next page*

**Action**

2 All mechanical units connected to the system are shown with their calibration status. Tap the mechanical unit in question.

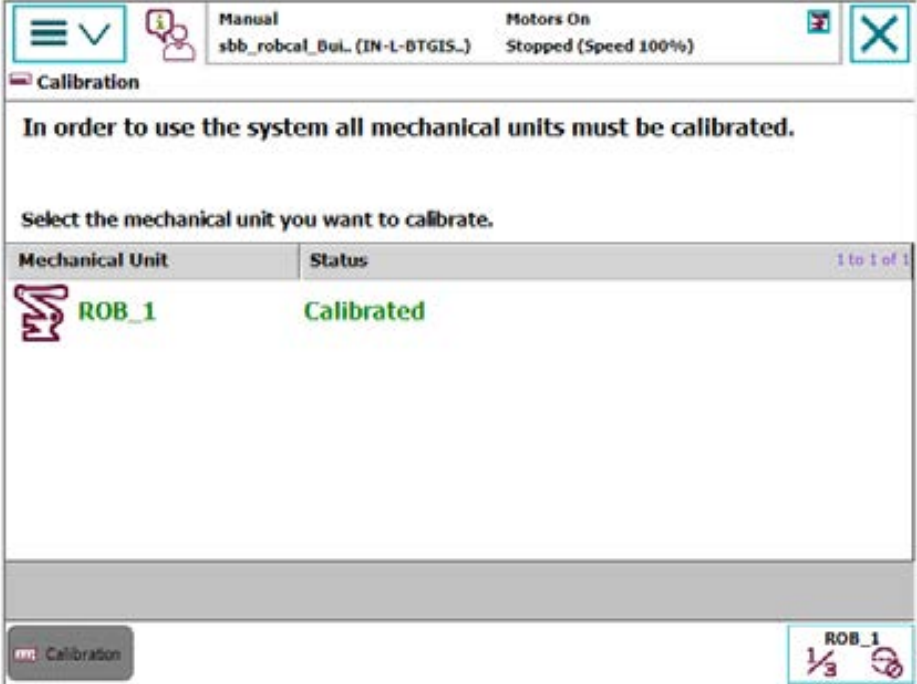

xx150000943

3 This step is valid for RobotWare 6.02 and later. Calibration method used at factory for each axis is shown, as well as calibration method used during last field calibration. Tap **Manual Method (Advanced)**.

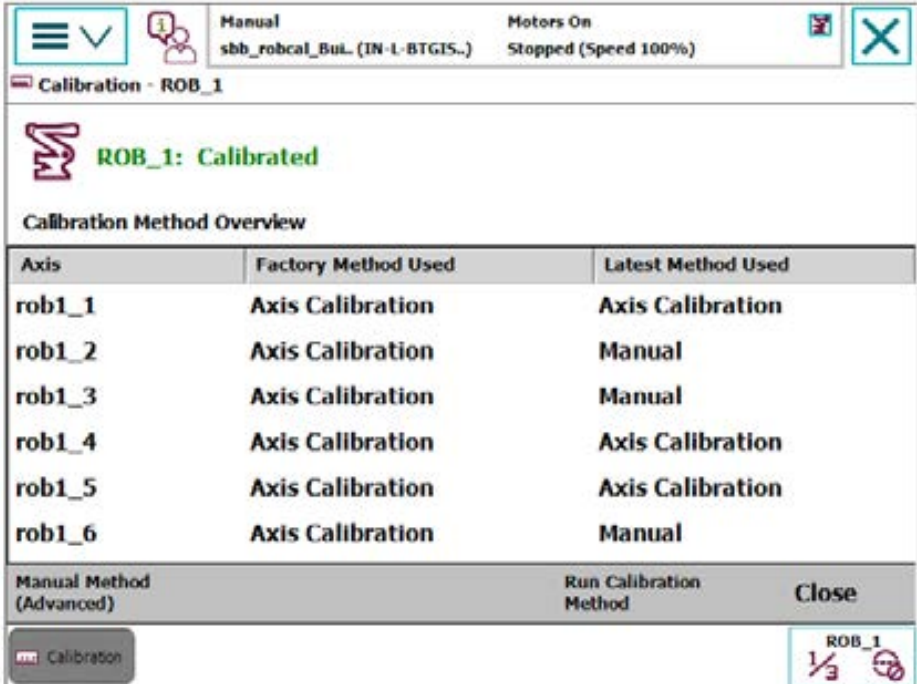

xx150000944



Axis	Factory Method Used	Latest Method Used
rob1_1	Axis Calibration	Axis Calibration
rob1_2	Axis Calibration	Manual
rob1_3	Axis Calibration	Manual
rob1_4	Axis Calibration	Axis Calibration
rob1_5	Axis Calibration	Axis Calibration
rob1_6	Axis Calibration	Manual

Continues on next page

## 5 Calibration

### 5.3 Updating revolution counters

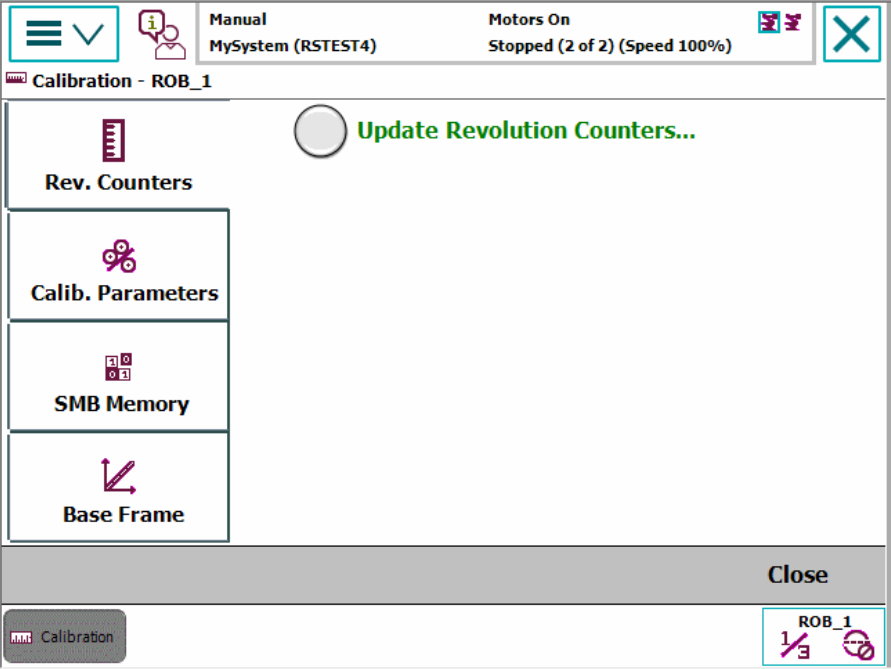
Continued

Action	
4	<p>A screen is displayed, tap <b>Rev. Counters</b>.</p>  <p>en0400000771</p>
5	<p>Tap <b>Update Revolution Counters...</b></p> <p>A dialog box is displayed, warning that updating the revolution counters may change programmed robot positions:</p> <ul style="list-style-type: none"><li>• Tap <b>Yes</b> to update the revolution counters.</li><li>• Tap <b>No</b> to cancel updating the revolution counters.</li></ul> <p>Tapping <b>Yes</b> displays the axis selection window.</p>
6	<p>Select the axis to have its revolution counter updated by:</p> <ul style="list-style-type: none"><li>• Ticking in the box to the left</li><li>• Tapping <b>Select all</b> to update all axes.</li></ul> <p>Then tap <b>Update</b>.</p>
7	<p>A dialog box is displayed, warning that the updating operation cannot be undone:</p> <ul style="list-style-type: none"><li>• Tap <b>Update</b> to proceed with updating the revolution counters.</li><li>• Tap <b>Cancel</b> to cancel updating the revolution counters.</li></ul> <p>Tapping <b>Update</b> updates the selected revolution counters and removes the tick from the list of axes.</p>
8	<p> <b>CAUTION</b></p> <p>If a revolution counter is incorrectly updated, it will cause incorrect manipulator positioning, which in turn may cause damage or injury!</p> <p>Check the synchronization position very carefully after each update. See <a href="#">Checking the synchronization position on page 368</a>.</p>



## 5.4 Calibrating with Axis Calibration method

### 5.4.1 Description of Axis Calibration

#### Instructions for Axis Calibration procedure given on the FlexPendant

The actual instructions of how to perform the calibration procedure and what to do at each step is given on the FlexPendant. You will be guided through the calibration procedure, step by step.

This manual contains a brief description of the method, additional information to the information given on the FlexPendant, article number for the tools and images of where to fit the calibration tools on the robot.

#### Overview of the Axis Calibration procedure

The Axis Calibration procedure applies to all axes, and is performed on one axis at the time. The robot axes are both manually and automatically moved into position, as instructed on the FlexPendant.

A fixed calibration pin/bushing is installed on each robot axis at delivery.

The Axis Calibration procedure described roughly:

- A removable calibration tool is inserted by the operator into a calibration bushing on the axis chosen for calibration, according to instructions on the FlexPendant.



#### WARNING

Calibrating the robot with Axis Calibration requires special calibration tools from ABB. Using other pins in the calibration bushings may cause severe damage to the robot and/or personnel.



#### WARNING

The calibration tool must be fully inserted into the calibration bushing, until the steel spring ring snaps into place.

- During the calibration procedure, RobotWare moves the robot axis chosen for calibration so that the calibration tools get into contact. RobotWare records values of the axis position and repeats the coming-in-contact procedure several times to get an exact value of the axis position.



#### WARNING

Risk of pinching! The contact force for large robots can be up to 150 kg. Keep a safe distance to the robot.

- The axis position is stored in RobotWare with an active choice from the operator.

*Continues on next page*

## 5 Calibration

---

### 5.4.1 Description of Axis Calibration

*Continued*

---

#### Routines in the calibration procedure

The following routines are available in the Axis Calibration procedure, given at the beginning of the procedure on the FlexPendant.

##### Fine calibration routine

Choose this routine to calibrate the robot when there are no tools, process cabling or equipment fitted to the robot.

##### Reference calibration routine

Choose this routine to create reference values and to calibrate the robot when the robot is dressed with tools, process cabling or other equipment.

Also choose this routine if the robot is wall mounted or suspended.

If calibrating the robot with reference calibration there must be reference values created before repair is made to the robot, if values are not already available. Creating new values requires possibility to move the robot. The reference values contain positions of all axes, torque of axes and technical data about the tool installed. A benefit with reference calibration is that the current state of the robot is stored and not the state when the robot left the ABB factory. The reference value will be named according to tool name, date etc.

Follow the instructions given in the reference calibration routine on the FlexPendant to create reference values.

When reference calibration is performed, the robot is restored to the status given by the reference values.



#### Note

When calibrating the robot with the reference calibration routine, the robot must be dressed with the same tools, process cabling and any other equipment as when the reference values were created.

##### Update revolution counters

Choose this routine to make a rough calibration of each manipulator axis by updating the revolution counter for each axis, using the FlexPendant.

##### Validation

In the mentioned routines, it is also possible to validate the calibration data.

---

#### Position of robot axes

The axis chosen for calibration is automatically run by the calibration program to its calibration position during the calibration procedure.

In order for the axis to be able to be moved to calibration position, or in order for getting proper access to the calibration bushing, other axes might need to be jogged to positions different from 0 degrees. Information about which axes are allowed to be jogged will be given on the FlexPendant. These axes are marked with **Unrestricted** in the FlexPendant window.

---

#### How to calibrate a suspended or wall mounted robot

The IRB 1600/1660ID is calibrated floor standing in factory, prior to shipping.

*Continues on next page*

To calibrate a suspended or wall mounted robot, reference calibration must be used. Reference values for a suspended or a wall mounted robot must be created with the robot mounted at its working position, not standing on a floor.

To calibrate a suspended or wall mounted robot with the fine calibration routine, the robot must first be taken down and mounted standing on the floor.

## 5 Calibration

### 5.4.2 Calibration tools for Axis Calibration

#### 5.4.2 Calibration tools for Axis Calibration

##### Calibration tool set

The calibration tools used for Axis Calibration are designed to meet requirements for calibration performance, durability and safety in case of accidental damage.

The calibration tool will eventually break from fatigue after longer period of use and then needs to be replaced. There is no risk for bad calibrations as long as the calibration tool is in one piece.



#### WARNING

Calibrating the robot with Axis Calibration requires special calibration tools from ABB. Using other pins in the calibration bushings may cause severe damage to the robot and/or personnel.

Equipment, etc.	Article number	Note
Calibration tool box, Axis Calibration	3HAC062326-001	Delivered as a set of calibration tools. Required if Axis Calibration is the valid calibration method for the robot. Contains a removal tool for removing special protection plugs on the turning disc.

##### Examining the calibration tool

##### Check prior to usage

Before using the calibration tool, make sure that the tube insert, the plastic protection and the steel spring ring are present.



#### WARNING

If any part is missing or damaged, the tool must be replaced immediately.

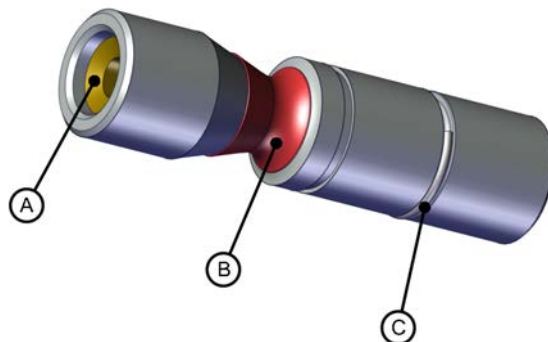

xx1500001914

A	Tube insert
B	Plastic protection
C	Steel spring ring

*Continues on next page*

#### Periodic check of the calibration tool

If including the calibration tool in a local periodic check system, the following measures should be checked.

- Outer diameter within  $\varnothing 12g4$  mm,  $\varnothing 8g4$  mm or  $\varnothing 6g5$  mm (depending on calibration tool size).
- Straightness within 0.005 mm.

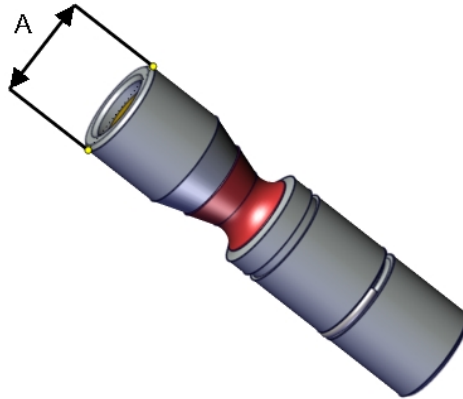

xx150000951

A	Outer diameter
---	----------------

## 5 Calibration

### 5.4.3 Installation locations for the calibration tools

### 5.4.3 Installation locations for the calibration tools

#### Location of fixed calibration items

This section shows how the robot is equipped with items for installation of calibration tools for Axis Calibration (fixed calibration pins and/or bushings). Installed calibration tools are not shown.

A fixed calibration pin and a bushing for the movable calibration tool are located on each axis as follows.

If there is not enough space on an axis to install a fixed calibration pin, the axis is equipped with two bushings instead, for installation of two calibration tools when calibration is carried out. This is shown in the figure.

IRB 1600

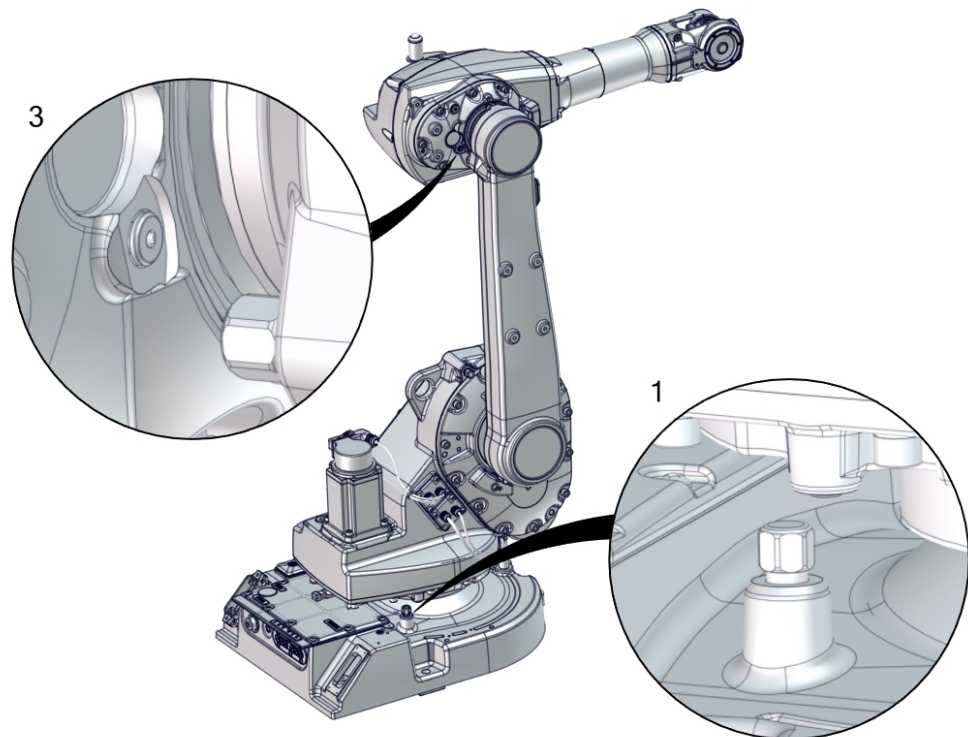

xx170000113

*Continues on next page*

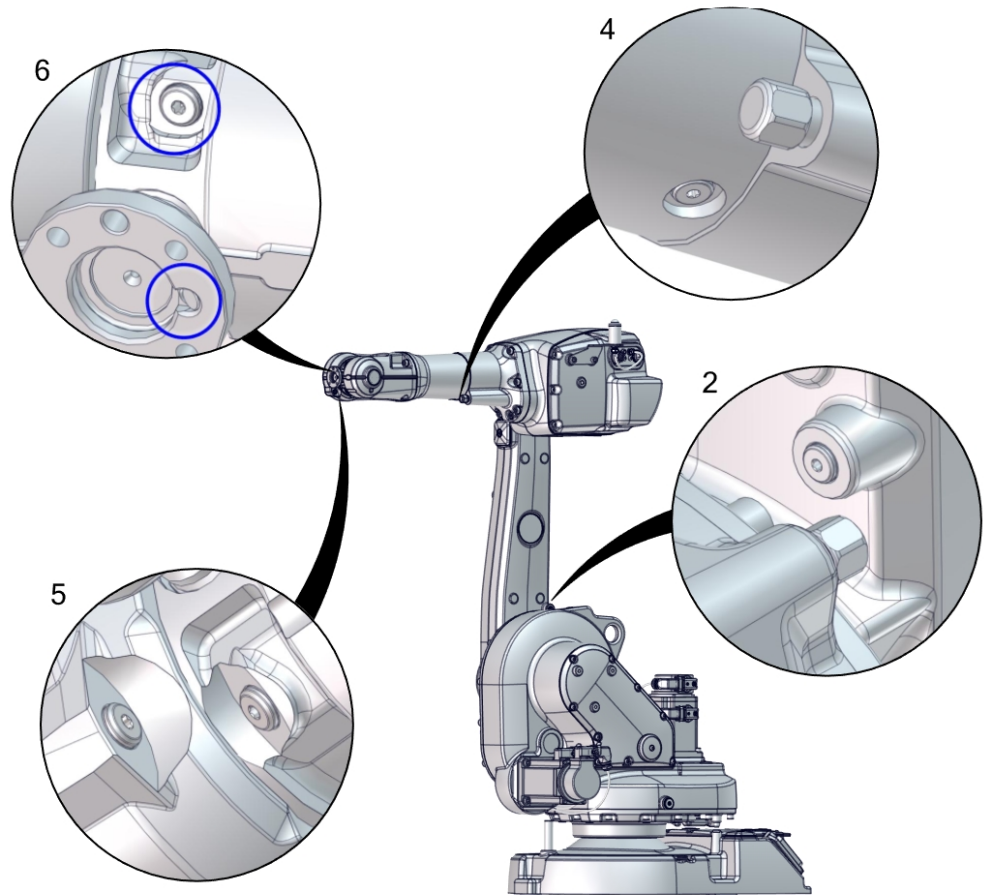

xx170000114

## 5 Calibration

### 5.4.3 Installation locations for the calibration tools

*Continued*

IRB 1660ID

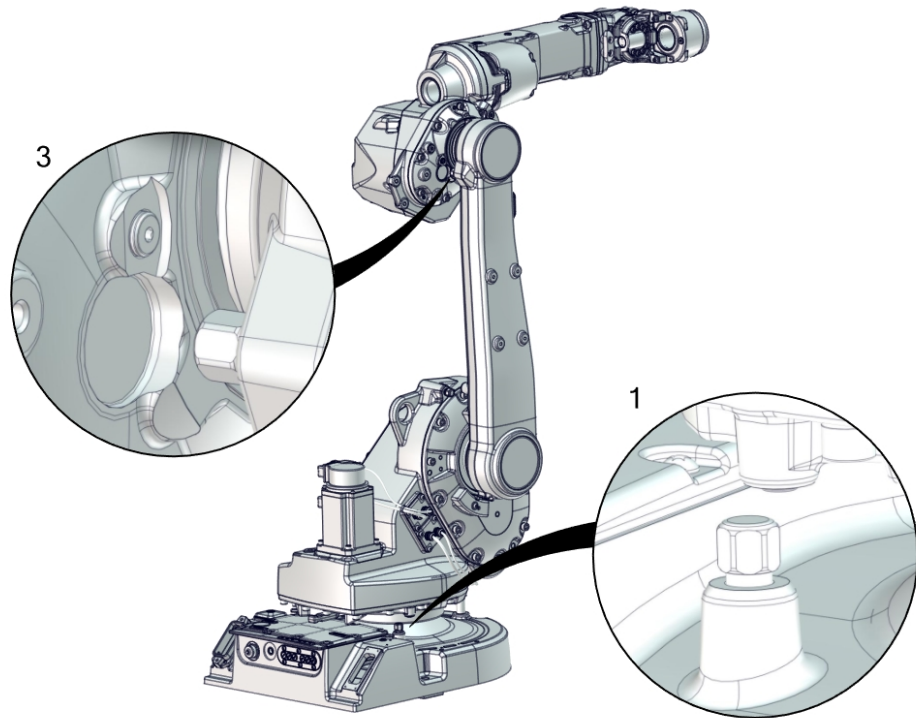

xx170000111

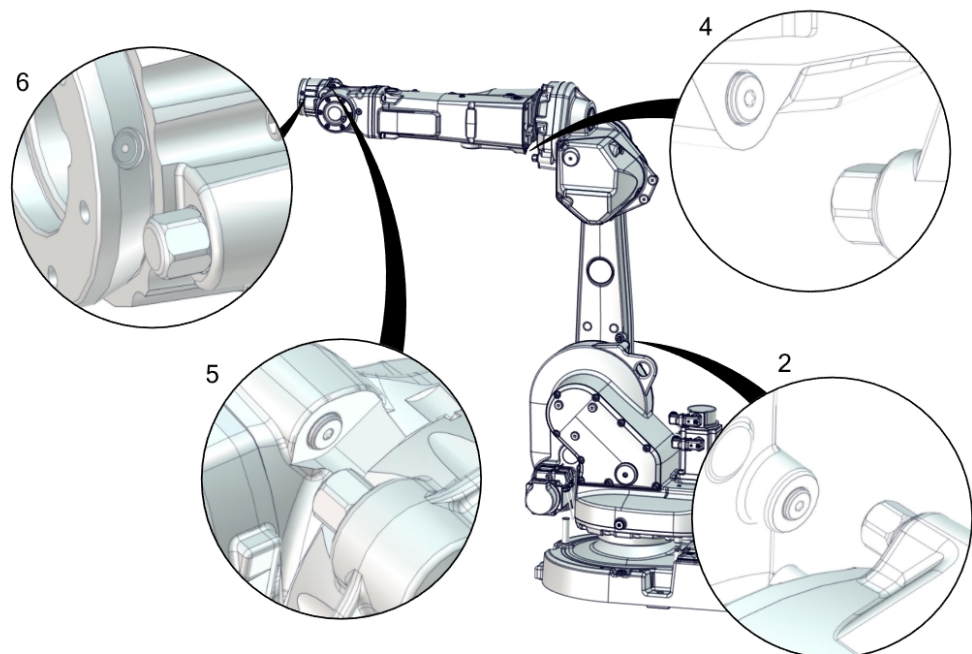

xx170000112

*Continues on next page*



**Spare parts**

When calibration is not being performed, a protective cover and an o-ring should always be installed on the fixed calibration pin as well as a protective plug, included a sealing, in the bushing. Replace damaged parts with new, if needed.

Spare part	Article number	Note
Protection cover and plug set	3HAC059487-001	Contains replacement calibration pin covers and protective plugs for the bushing.
Protective plug on turning disc	3HAC057676-001 (IRB 1660ID) 3HAC061134-001 (IRB 1600)	Replace if damaged or missing.

## 5 Calibration

### 5.4.4 Axis Calibration - Running the calibration procedure

#### 5.4.4 Axis Calibration - Running the calibration procedure

##### Required tools

The calibration tools used for Axis Calibration are designed to meet requirements for calibration performance, durability and safety in case of accidental damage.



##### WARNING

Calibrating the robot with Axis Calibration requires special calibration tools from ABB. Using other pins in the calibration holes may cause severe damage to the robot and/or personnel.

Equipment, etc.	Article number	Note
Calibration tool box, Axis Calibration	3HAC062326-001	Delivered as a set of calibration tools. Required if Axis Calibration is the valid calibration method for the robot. Contains a removal tool for removing special protection plugs on the turning disc.

##### Required consumables

Consumable	Article number	Note
Clean cloth	-	

##### Spare parts

Spare part	Article number	Note
Protection cover and plug set	3HAC059487-001	Contains replacement calibration pin covers and protective plugs for the bushing.
Protective plug on turning disc	3HAC057676-001 (IRB 1660ID) 3HAC061134-001 (IRB 1600)	Replace if damaged or missing.

##### Overview of the calibration procedure on the FlexPendant

The actual instructions of how to perform the calibration procedure and what to do at each step is given on the FlexPendant. You will be guided through the calibration procedure, step by step.

Use the following list to learn about the calibration procedure before running the RobotWare program on the FlexPendant. It gives you a brief overview of the calibration procedure sequence.

After the calibration method has been called for on the FlexPendant, the following sequence will be run.

- 1 Choose calibration routine. The routines are described in [Routines in the calibration procedure on page 350](#).
- 2 Choose which axis/axes to calibrate.
- 3 The robot moves to synchronization position.

*Continues on next page*

### 5.4.4 Axis Calibration - Running the calibration procedure *Continued*

- 4 Validate the synchronization marks.
- 5 The robot moves to preparation position.
- 6 Remove the protective cover from the fixed pin and the protection plug from the bushing, if any, and install the calibration tool.

Use the removal tool included in the calibration tool box to remove the special protection plug(s) on the turning disc.

#### IRB 1600

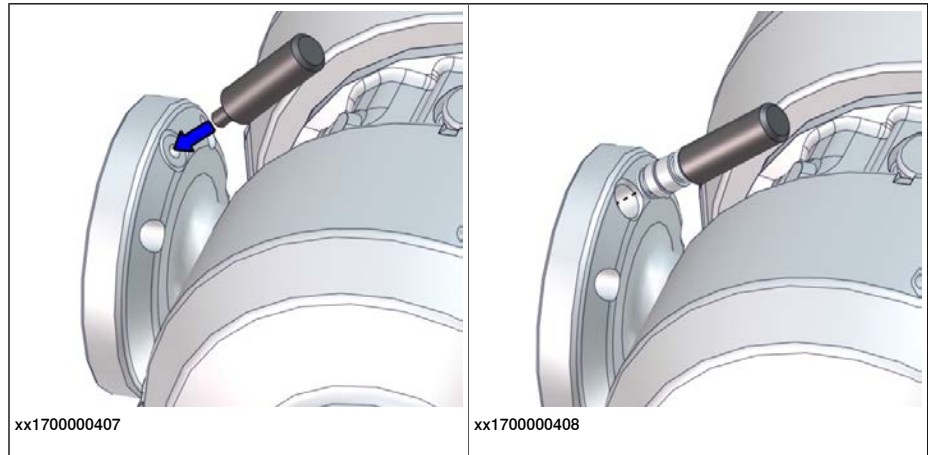

#### IRB 1660ID

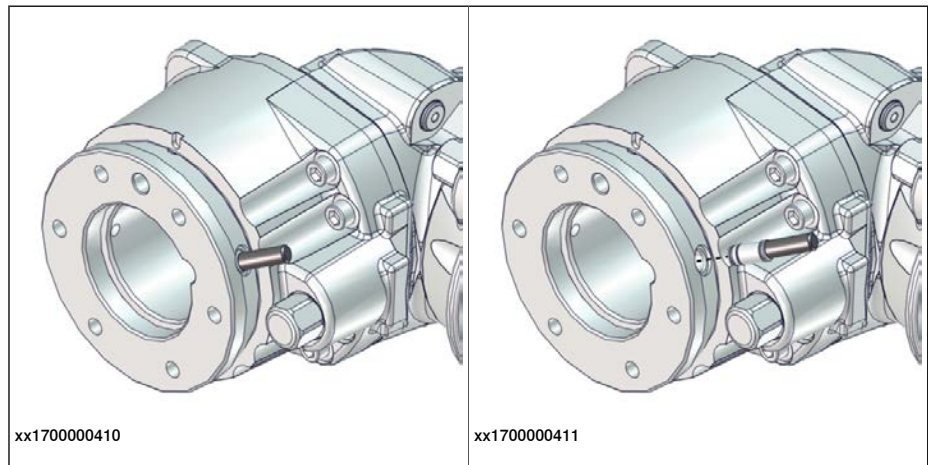

When calibrating axis 6, push in the calibration tool into the turning disc until the snap ring engages, no further.

On IRB 1600, this makes the calibration tool to stick out on the other side of the turning disc. Any equipment fitted to the turning disc must therefore either be removed or designed with a cavity, giving space to the calibration tool to stick out.

- 7 The robot performs a measurement sequence by rotating the axis back and forth.
- 8 Remove the calibration tool and reinstall the protective cover on the fixed pin and the protection plug in the bushing, if any.

Refit the protection plug(s) to the turning disc, push until the steel spring ring snaps into place.

*Continues on next page*

## 5 Calibration

### 5.4.4 Axis Calibration - Running the calibration procedure

*Continued*



9 The robot moves to verify that the calibration tool is removed.

10 Choose whether to save the calibration data or not.

Calibration of the robot is not finished until the calibration data is saved, as last step of the calibration procedure.

#### Preparation prior to calibration

The calibration procedure is described in the FlexPendant while conducting it.

	Action	Note
1	 <b>DANGER</b> While conducting the calibration, the robot needs to be connected to power. Make sure that the robots working area is empty, as the robot can make unpredictable movements.	
2	Wipe the calibration tool clean.  <b>Note</b> The calibration method is exact. Dust, dirt or color flakes will affect the calibration value.	Use a clean cloth.

#### Starting the calibration procedure

Use this procedure to call for the Axis Calibration method on the FlexPendant.

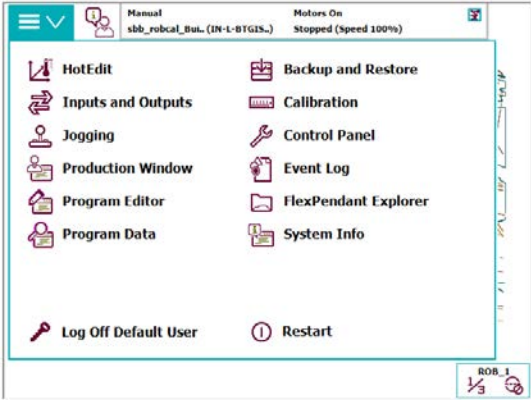
	Action	Note
1	On the <b>ABB</b> menu, tap <b>Calibration</b> . 	

*Continues on next page*

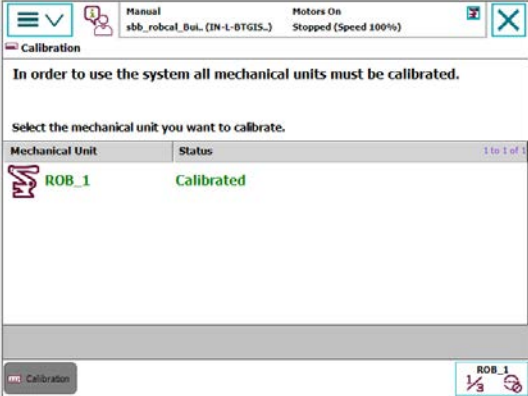
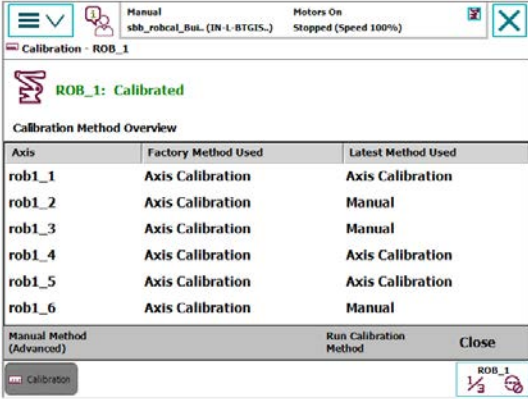
	Action	Note
2	<p>All mechanical units connected to the system are shown with their calibration status. Tap the mechanical unit in question.</p>  <p>xx1500000943</p>	
3	<p>Calibration method used at factory for each axis is shown, as well as calibration method used for the robot during last field calibration. Tap <b>Run Calibration Method</b>. The software will automatically call for the procedure for the valid calibration method.</p>  <p>xx1500000944</p>	<p>The FlexPendant will give all information needed to proceed with Axis Calibration.</p>
4	<p>Follow the instructions given on the FlexPendant.</p>	<p>A brief overview of the sequence that will be run on the FlexPendant is given in <a href="#">Overview of the calibration procedure on the FlexPendant on page 358</a>.</p>

**Restarting an interrupted calibration procedure**

If the Axis Calibration procedure is interrupted before the calibration is finished, the RobotWare program needs to be started again. Use this procedure to take required action.

Situation	Action
The three-position enabling device on the FlexPendant has been released during robot movement.	Press and hold the three-position enabling device and press <b>Play</b> .

*Continues on next page*

## 5 Calibration

### 5.4.4 Axis Calibration - Running the calibration procedure

Continued

Situation	Action
The RobotWare program is terminated with <b>PP to Main</b> .	<p>Remove the calibration tool, if it is installed, and restart the calibration procedure from the beginning. See <a href="#">Starting the calibration procedure on page 360</a>.</p> <p>If the calibration tool is in contact the robot axis needs to be jogged in order to release the calibration tool. Jogging the axis in wrong direction will cause the calibration tool to break. Directions of axis movement is shown in <a href="#">Calibration movement directions for all axes on page 344</a></p>

#### Axis Calibration with SafeMove option

To be able to run Axis Calibration SafeMove needs to be unsynchronized. The Axis Calibration routine recognizes if the robot is equipped with SafeMove and will force SafeMove to unsynchronize automatically.

However, SafeMove may generate other warning messages anytime during the Axis Calibration routine.

#### Safety controller not synchronized - SafeMove message

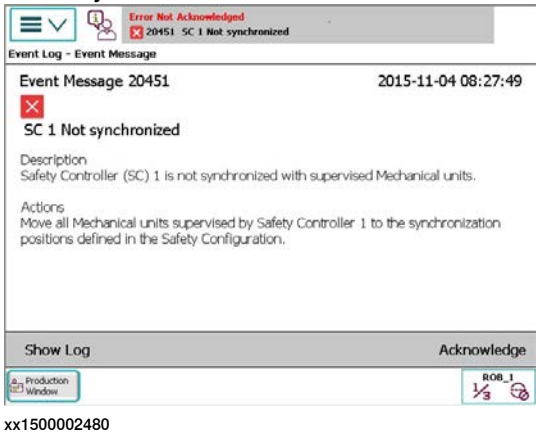
	Action	Note
1	<p>SafeMove generates the message "Safety controller not synchronized".</p> 	
2	Confirm unsynchronized state by pressing <b>Acknowledge</b> to continue Axis Calibration procedure.	
3	Restart Axis Calibration procedure by pressing <b>Play</b> .	

Continues on next page

5.4.4 Axis Calibration - Running the calibration procedure  
Continued

Unsynchronized speed exceeded - SafeMove message while saving robot data

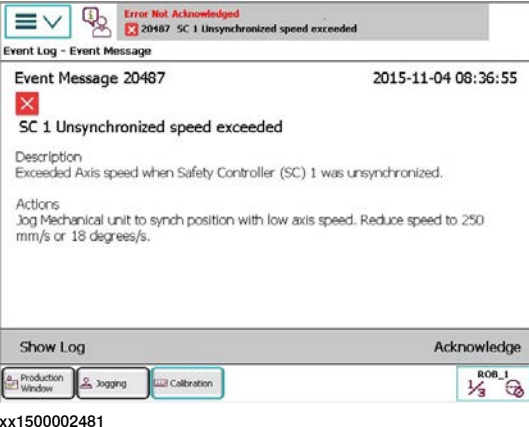
	Action	Note
1	<p>SafeMove generates the message "Unsynchronized speed exceeded" while saving robot data.</p>  <p>xx1500002481</p>	
2	Press <b>Acknowledge</b> to continue Axis Calibration procedure.	
3	Restart Axis Calibration procedure by pressing <b>Play</b> .	

Unsynchronized time limit expired - SafeMove message anytime during Axis Calibration routine

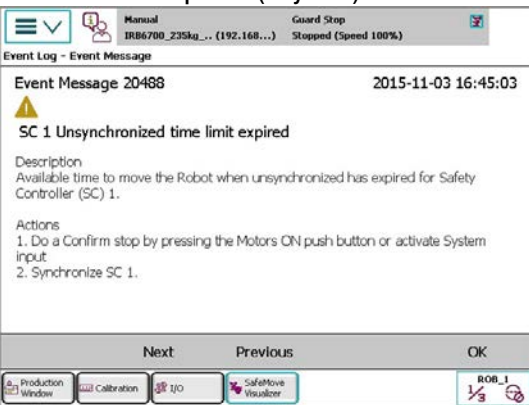
	Action	Note
1	<p>SafeMove generates the message "Unsynchronized time limit expired" (anytime).</p>  <p>xx1500002482</p>	
2	Press <b>OK</b> to continue Axis Calibration procedure.	
3	Restart Axis Calibration procedure by pressing <b>Play</b> .	

Continues on next page

## 5 Calibration

### 5.4.4 Axis Calibration - Running the calibration procedure

*Continued*

#### After calibration

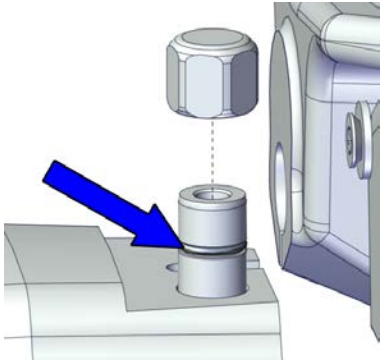
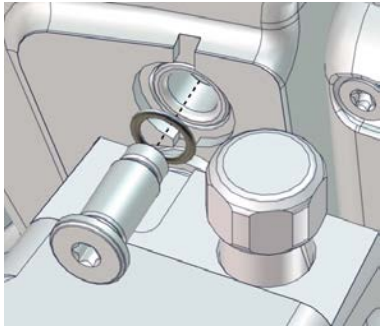
	Action	Note
1	Check the o-ring on the fixed calibration pin. Replace if damaged or missing.	
2	Reinstall the protective cover on the fixed calibration pin on each axis, directly after the axis has been calibrated. Replace the cover with new spare part, if missing or damaged.	 <p data-bbox="1027 725 1139 745">xx1600002102</p> <p data-bbox="1027 763 1366 817">Protection cover and plug set: 3HAC059487-001.</p>
3	Reinstall the protective plug and sealing in the bushing on each axis, directly after the axis has been calibrated. Ensure that the sealing is not damaged. Replace the plug and the sealing with new spare part, if missing or damaged.	 <p data-bbox="1027 1164 1139 1184">xx1500000952</p> <p data-bbox="1027 1202 1366 1256">Protection cover and plug set: 3HAC059487-001.</p>

*Continues on next page*

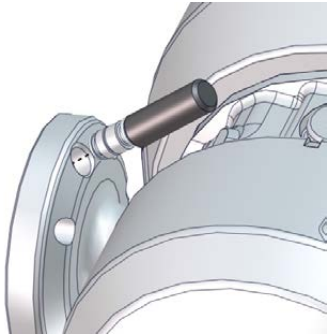
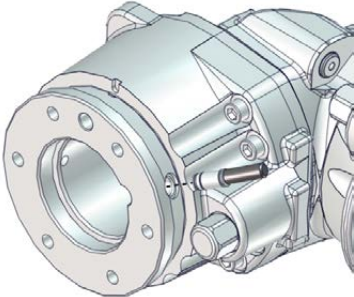
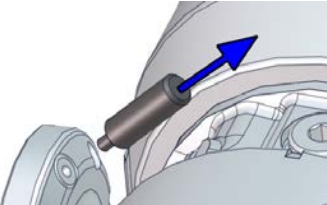
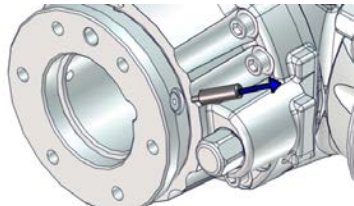

5.4.4 Axis Calibration - Running the calibration procedure  
Continued

	Action	Note
4	Refit the special protection plug to the turning disc using the tool included in the calibration tool box.	<p>IRB 1600</p>  <p>xx1700000408</p> <p>IRB 1660ID</p>  <p>xx1700000411</p>
5	Remove the tool from the protection plug.	<p>IRB 1600</p>  <p>xx1700000901</p> <p>IRB 1660ID</p>  <p>xx1700000902</p>

## 5 Calibration

---

### 5.5 Calibrating with Calibration Pendulum method

### 5.5 Calibrating with Calibration Pendulum method

---

#### Where to find information for Calibration Pendulum

Detailed instructions of how to perform Pendulum Calibration are given in the documentation enclosed with the calibration tools.

## 5.6 Verifying the calibration

### Introduction

Always verify the results after calibrating *any* robot axis to verify that all calibration positions are correct.

### Verifying the calibration

Use this procedure to verify the calibration result.

	Action	Note
1	Run the calibration home position program twice. Do not change the position of the robot axes after running the program!	See <a href="#">Checking the synchronization position on page 368</a> .
2	Adjust the <i>synchronization marks</i> when the calibration is done, if necessary.	This is detailed in section <a href="#">Synchronization marks and synchronization position for axes on page 341</a> .
3	Write down the values on a new label and stick it on top of the calibration label. xx	
4	Remove any calibration equipment from the robot.	

## 5 Calibration

### 5.7 Checking the synchronization position

### 5.7 Checking the synchronization position

#### Introduction

Check the synchronization position of the robot before beginning any programming of the robot system. This may be done:

- Using a `MoveAbsJ` instruction with argument zero on all axes.
- Using the **Jogging** window on the FlexPendant.

#### Using a `MoveAbsJ` instruction

Use this procedure to create a program that runs all the robot axes to their synchronization position.

	Action	Note
1	On ABB menu tap <b>Program editor</b> .	
2	Create a new program.	
3	Use <b>MoveAbsJ</b> in the <b>Motion&amp;Proc</b> menu.	
4	Create the following program: <pre>MoveAbsJ [[0,0,0,0,0,0],           [9E9,9E9,9E9,9E9,9E9,9E9]]         \NoEOffs, v1000, fine, tool0</pre>	
5	Run the program in manual mode.	
6	Check that the synchronization marks for the axes align correctly. If they do not, update the revolution counters.	See <a href="#">Synchronization marks and synchronization position for axes on page 341</a> and <a href="#">Updating revolution counters on page 345</a> .

#### Using the jogging window

Use this procedure to jog the robot to the synchronization position of all axes.

	Action	Note
1	On the <b>ABB</b> menu, tap <b>Jogging</b> .	
2	Tap <b>Motion mode</b> to select group of axes to jog.	
3	Tap to select the axis to jog, axis 1, 2, or 3.	
4	Manually run the robots axes to a position where the axis position value read on the FlexPendant, is equal to zero.	
5	Check that the synchronization marks for the axes align correctly. If they do not, update the revolution counters.	See <a href="#">Synchronization marks and synchronization position for axes on page 341</a> and <a href="#">Updating revolution counters on page 345</a> .

## 6 Decommissioning

### 6.1 Environmental information

#### Symbol

The following symbol indicates that the product must not be disposed of as common garbage. Handle each product according to local regulations for the respective content (see table below).

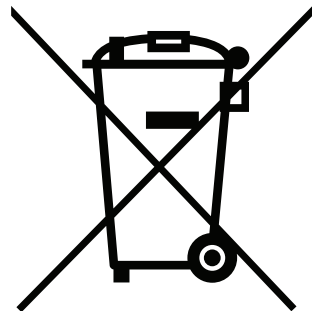

xx180000058

#### Hazardous material

The table specifies some of the materials in the product and their respective use throughout the product.

Dispose components properly according to local regulations to prevent health or environmental hazards.

Material	Example application
Batteries, NiCad or Lithium	Serial measurement board
Copper	Cables, motors
Cast iron/nodular iron	Base, lower arm
Steel	Gears, screws, base frame, and so on.
Neodymium	Brakes, motors
Plastic/rubber	Cables, connectors, drive belts, and so on.
Oil, grease	Gearboxes
Aluminium	Covers, synchronization brackets, upper arm
Nickel	Turning disc (foundry)

#### Oil and grease

Where possible, arrange for oil and grease to be recycled. Dispose of via an authorized person/contractor in accordance with local regulations. Do not dispose of oil and grease near lakes, ponds, ditches, down drains, or onto soil. Incineration must be carried out under controlled conditions in accordance with local regulations.

*Continues on next page*

## 6 Decommissioning

---

### 6.1 Environmental information

*Continued*

Also note that:

- Spills can form a film on water surfaces causing damage to organisms. Oxygen transfer could also be impaired.
- Spillage can penetrate the soil causing ground water contamination.

## 6.2 Scrapping of robot

### Important when scrapping the robot



#### **DANGER**

When a robot is disassembled while being scrapped, it is very important to remember the following before disassembling starts, in order to prevent injuries:

- Always remove all batteries. If a battery is exposed to heat, for example from a blow torch, it will explode.
- Always remove all oil/grease in gearboxes. If exposed to heat, for example from a blow torch, the oil/grease will catch fire.
- When motors are removed from the robot, the robot will collapse if it is not properly supported before the motor is removed.

**This page is intentionally left blank**



## 7 Robot description

### 7.1 Type A of IRB 1600

---

#### Type A - new upper arm and wrist

Type A of IRB 1600 have a new upper arm, complete and a new wrist unit. As a result of this, the following parts differ from earlier versions:

- Upper arm, complete
  - Wrist unit
  - O-ring sealingplate
- 

#### How to know which type the robot is?

The identification plate on the cabinet and the lower arm of the robot tells if the robot has a new upper arm and wrist or not.

Those robots with a new upper arm and wrist are named IRB 1600, type A.

Those robots which are not equipped with a new upper arm and wrist are simply named IRB 1600 (no type specified).

---

#### Which parts are interchangeable and which are not?

The following parts are interchangeable.

- The upper arm, complete with spare part no. 3HAC026567-001 is **interchangeable** with spare part no. 3HAC023630-001. **Note!** Software version 5.07.01 is needed!

The following parts are **not** interchangeable:

- The wrist unit with spare part no. 3HAC026569-001 is **not** interchangeable with spare part no. 3HAC10475-1.
  - The o-ring sealingplate with spare part no. 3HAC025420-001 is **not** interchangeable with spare part no. 3HAC 7191-1.
- 

#### Other changes in this product manual, compared to product manual IRB 1600, 3HAC023637-001

The content in this product manual is the same as in the product manual with art. no. 3HAC023637-001, except for the new upper arm complete and the new wrist unit for type A. In order to distinguish IRB 1600 type A from earlier versions, a new art. no. has been created.

There has been a few other changes in the manual, not related to the IRB 1600 type A. These changes are described below:

- The cable harness for motors axes 1-2 has got a new spare part no. The motors axes 1-2 (3HAC023557-001) and the cable harness, motors axes 1-2 (3HAC023754-001) now have two separate spare part no:s.
- Some cable harnesses have been replaced.

For details, see *Base, spare part list* and *Frame, spare part list*, in *Product manual, spare parts - IRB 1600/1660*.

---

## 7 Robot description

---

### 7.2 Type A of IRB 1600ID

### 7.2 Type A of IRB 1600ID

---

#### Type A - changes in the ISO data

IRB 1600ID robots delivered as from R 11.2/RW 5.14.02, have designation Type A due to new basic tuning and a different MOC.cfg structure.

---

#### Upgrade from IRB 1600ID to IRB 1600ID type A

To upgrade an existing installation with the IRB 1600ID to the IRB 1600ID Type A version, with improved performance, a new drive module key with Type A version of the robot is needed. The new key then has to be used instead of the old by modifying the existing system in System Builder in RobotStudio. Please contact Robotics After Sales for more information and purchase of a new key.

After the upgrade the existing programs may require a touch-up of positions.

---

#### Further information

Technote 110912 includes more detailed information. Contact Robotics After Sales.

## 8 Reference information

### 8.1 Introduction

---

#### General

This chapter includes general information, complementing the more specific information in the different procedures in the manual.

## 8 Reference information

### 8.2 Applicable standards

### 8.2 Applicable standards



#### Note

The listed standards are valid at the time of the release of this document. Phased out or replaced standards are removed from the list when needed.

#### Standards, EN ISO

The product is designed in accordance with the requirements of:

Standard	Description
EN ISO 12100:2010	Safety of machinery - General principles for design - Risk assessment and risk reduction
EN ISO 13849-1:2015	Safety of machinery, safety related parts of control systems - Part 1: General principles for design
EN ISO 13850:2015	Safety of machinery - Emergency stop - Principles for design
EN ISO 10218-1:2011	Robots for industrial environments - Safety requirements -Part 1 Robot
ISO 9787:2013	Robots and robotic devices -- Coordinate systems and motion nomenclatures
ISO 9283:1998	Manipulating industrial robots, performance criteria, and related test methods
EN ISO 14644-1:2015 <sup>i</sup>	Classification of air cleanliness
EN ISO 13732-1:2008	Ergonomics of the thermal environment - Part 1
EN 61000-6-4:2007 + A1:2011 IEC 61000-6-4:2006 + A1:2010 (option 129-1)	EMC, Generic emission
EN 61000-6-2:2005 IEC 61000-6-2:2005	EMC, Generic immunity
EN IEC 60974-1:2012 <sup>ii</sup>	Arc welding equipment - Part 1: Welding power sources
EN IEC 60974-10:2014 <sup>ii</sup>	Arc welding equipment - Part 10: EMC requirements
EN IEC 60204-1:2006	Safety of machinery - Electrical equipment of machines - Part 1 General requirements
IEC 60529:1989 + A2:2013	Degrees of protection provided by enclosures (IP code)

<sup>i</sup> Only robots with protection Clean Room.

<sup>ii</sup> Only valid for arc welding robots. Replaces EN IEC 61000-6-4 for arc welding robots.

#### European standards

Standard	Description
EN 614-1:2006 + A1:2009	Safety of machinery - Ergonomic design principles - Part 1: Terminology and general principles
EN 574:1996 + A1:2008	Safety of machinery - Two-hand control devices - Functional aspects - Principles for design

*Continues on next page*

---

#### Other standards

Standard	Description
ANSI/RIA R15.06	Safety requirements for industrial robots and robot systems
ANSI/UL 1740	Safety standard for robots and robotic equipment
CAN/CSA Z 434-14	Industrial robots and robot Systems - General safety requirements

## 8 Reference information

---

### 8.3 Unit conversion

### 8.3 Unit conversion

---

#### Converter table

Use the following table to convert units used in this manual.

Quantity	Units		
Length	1 m	3.28 ft.	39.37 in
Weight	1 kg	2.21 lb.	
Weight	1 g	0.035 ounces	
Pressure	1 bar	100 kPa	14.5 psi
Force	1 N	0.225 lbf	
Moment	1 Nm	0.738 lbf-ft	
Volume	1 L	0.264 US gal	

## 8.4 Screw joints

### General

This section describes how to tighten the various types of screw joints on the IRB 1600/1660ID.

The instructions and torque values are valid for screw joints comprised of metallic materials and do *not* apply to soft or brittle materials.

### UNBRAKO screws

UNBRAKO is a special type of screw recommended by ABB for certain screw joints. It features special surface treatment (Gleitmo as described below) and is extremely resistant to fatigue.

Whenever used, this is specified in the instructions, and in such cases, *no other type of replacement screw* is allowed. Using other types of screws will void any warranty and may potentially cause serious damage or injury.

### Gleitmo treated screws

Gleitmo is a special surface treatment to reduce the friction when tightening the screw joint. Screws treated with Gleitmo may be reused 3-4 times before the coating disappears. After this the screw must be discarded and replaced with a new one.

When handling screws treated with Gleitmo, protective gloves of **nitrile rubber** type should be used.

### Screws lubricated in other ways

Screws lubricated with Molycote 1000 should *only* be used when specified in the repair, maintenance or installation procedure descriptions.

In such cases, proceed as follows:

- 1 Apply lubricant to the screw thread.
- 2 Apply lubricant between the plain washer and screw head.
- 3 Screw dimensions of M8 or larger must be tightened with a torque wrench. Screw dimensions of M6 or smaller may be tightened without a torque wrench *if this is done by trained and qualified personnel.*

Lubricant	Article number
Molycote 1000 (molybdenum disulphide grease)	3HAC042472-001

### Tightening torque

Before tightening any screw, note the following:

- Determine whether a **standard** tightening torque or **special** torque is to be applied. The **standard torques** are specified in the following tables. Any **special torques** are specified in the repair, maintenance or installation procedure descriptions. **Any special torque specified overrides the standard torque!**
- Use the *correct tightening torque* for each type of screw joint.
- Only use *correctly calibrated* torque keys.

*Continues on next page*

## 8 Reference information

### 8.4 Screw joints

*Continued*

- Always *tighten the joint by hand*, and never use pneumatic tools.
- Use the *correct tightening technique*, that is *do not jerk*. Tighten the screw in a slow, flowing motion.
- Maximum allowed total deviation from the specified value is **10%**!

#### Oil-lubricated screws with slotted or cross-recess head screws

The following table specifies the recommended standard tightening torque for *oil-lubricated screws with slotted or cross-recess head screws*.



#### Note

A special torque specified in the repair, maintenance or installation procedure overrides the standard torque.

#### Oil-lubricated screws with allen head screws

The following table specifies the recommended standard tightening torque for *oil-lubricated screws with allen head screws*.



#### Note

A special torque specified in the repair, maintenance or installation procedure overrides the standard torque.

Dimension	Tightening torque (Nm) Class 8.8, oil-lubricated	Tightening torque (Nm) Class 10.9, oil-lubricated	Tightening torque (Nm) Class 12.9, oil-lubricated
M5	6	-	-
M6	10	-	-
M8	24	34	40
M10	47	67	80
M12	82	115	140
M16	200	290	340
M20	400	560	670
M24	680	960	1150

#### Lubricated screws (Molycote, Gleitmo or equivalent) with allen head screws

The following table specifies the recommended standard tightening torque for *screws lubricated with Molycote 1000, Gleitmo 603 or equivalent with allen head screws*.



#### Note

A special torque specified in the repair, maintenance or installation procedure overrides the standard torque.

Dimension	Tightening torque (Nm) Class 10.9, lubricated <sup>i</sup>	Tightening torque (Nm) Class 12.9, lubricated <sup>i</sup>
M8	28	35

*Continues on next page*



Dimension	Tightening torque (Nm) Class 10.9, lubricated <sup>i</sup>	Tightening torque (Nm) Class 12.9, lubricated <sup>i</sup>
M10	55	70
M12	96	120
M16	235	280
M20	460	550
M24	790	950

<sup>i</sup> Lubricated with Molycote 1000, Gleitmo 603 or equivalent

#### Water and air connectors

The following table specifies the recommended standard tightening torque for *water and air connectors* when *one or both* connectors are made of *brass*.



#### Note

A special torque specified in the repair, maintenance or installation procedure overrides the standard torque.

Dimension	Tightening torque Nm - Nominal	Tightening torque Nm - Min.	Tightening torque Nm - Max.
1/8	12	8	15
1/4	15	10	20
3/8	20	15	25
1/2	40	30	50
3/4	70	55	90

## 8 Reference information

---

### 8.5 Weight specifications

### 8.5 Weight specifications

---

#### Definition

In installation, repair, and maintenance procedures, weights of the components handled are sometimes specified. All components exceeding 22 kg (50 lbs) are highlighted in this way.

To avoid injury, ABB recommends the use of a lifting accessory when handling components with a weight exceeding 22 kg. A wide range of lifting accessories and devices are available for each manipulator model.

---

#### Example

Following is an example of a weight specification in a procedure:

Action	Note
<p> <b>CAUTION</b></p> <p>The robot weighs . IRB 1600/IRB 1600ID: 250 kg IRB 1660ID: 260 kg All lifting accessories used must be sized accordingly.</p>	

## 8.6 Standard tools

### General

All service (repairs, maintenance, and installation) procedures contains lists of tools required to perform the specified activity.

All special tools required are listed directly in the procedures while all the tools that are considered standard are gathered in the standard toolkit and defined in the following table.

This way, the tools required are the sum of the standard toolkit and any tools listed in the instruction.

### Contents, standard toolkit

Qty	Tool
1	Ring-open-end spanner 8-19 mm
1	Socket head cap 2.5-17 mm
1	Torx socket no: 20-60
1	Torque wrench 10-100 Nm
1	Small screwdriver
1	Plastic mallet
1	Ratchet head for torque wrench 1/2"
1	Socket head cap no: 5, socket 1/2" bit L 20 mm
1	Socket head cap no: 6, socket 1/2" bit L 20 mm
1	Socket head cap no: 8, socket 1/2" bit L 20 mm
1	Small cutting plier
1	T-handle with ball head

## 8 Reference information

### 8.7 Special tools

### 8.7 Special tools

#### General

All service instructions contain lists of tools required to perform the specified activity. The required tools are a sum of standard tools, defined in the section [Standard tools on page 383](#), and of special tools, listed directly in the instructions and also gathered in this section.

#### Measuring tools, play

The tools listed for measuring the play are used after service work on axes 5 and 6.

Description	Robot variant	Art. no.
Measuring tool, play	IRB 1600ID/1660ID	3HAB9238-1
Turning disk adapter	IRB 1600ID/1660ID	3HAC027717-020
Measuring bracket	IRB 1600ID/1660ID	3HAC032976-001

#### Special tools

The following table specifies all the tools, not considered standard, used when performing service activities on the robot. The special tools are also listed directly in the instructions.

Description	Art. no.	Note
Rotation tool, motor	3HAC022266-003	Used to adjust the gear play on all motors.
Dynamometer	-	Capacity: 100N
Hook	3HAC024045-001	Used to tighten the timing belt of axis 6, together with the dynamometer.
Belt tightener	3HAC024044-001	Used to tighten the timing belt of axis 5, together with the dynamometer.
Lifting tool, gearbox	3HAC023364-001	
Lifting tool, upper arm	3HAC062980-001	

#### Calibration equipment, Calibration Pendulum

The following table specifies the calibration equipment needed when calibrating the robot with the Calibration Pendulum method.

The robot is calibrated by either Calibration Pendulum or Axis Calibration at factory. Always use the same calibration method as used at the factory.

Information about valid calibration method is found on the calibration label or in the calibration menu on the FlexPendant.

If no data is found related to standard calibration, Calibration Pendulum is used as default.

Description	Art. no.	Note
Calibration Pendulum toolkit	3HAC15716-1	Complete kit that also includes operating manual.

*Continues on next page*

**Calibration equipment, Axis Calibration**

The following table specifies the calibration equipment needed when calibrating the robot with the Axis Calibration method.

The robot is calibrated by either Calibration Pendulum or Axis Calibration at factory. Always use the same calibration method as used at the factory.

Information about valid calibration method is found on the calibration label or in the calibration menu on the FlexPendant.

If no data is found related to standard calibration, Calibration Pendulum is used as default.

Description	Art. no.	Note
Calibration tool box, Axis Calibration	3HAC062326-001	Delivered as a set of calibration tools. Required if Axis Calibration is the valid calibration method for the robot. Contains a removal tool for removing special protection plugs on the turning disc.

## 8 Reference information

---

### 8.8 Lifting accessories and lifting instructions

### 8.8 Lifting accessories and lifting instructions

---

#### General

Many repair and maintenance activities require different pieces of lifting accessories, which are specified in each procedure.

The use of each piece of lifting accessories is *not* detailed in the activity procedure, but in the instruction delivered with each piece of lifting accessories.

This implies that the instructions delivered with the lifting accessories should be stored for later reference.

## 9 Spare part lists

### 9.1 Spare part lists and illustrations

---

#### Location

Spare parts and exploded views are not included in the manual but delivered as a separate document for registered users on myABB Business Portal, [www.myportal.abb.com](http://www.myportal.abb.com).

**This page is intentionally left blank**



# 10 Circuit diagram

## 10.1 Circuit diagrams

### Overview

The circuit diagrams are not included in this manual, but are available for registered users on myABB Business Portal, [www.myportal.abb.com](http://www.myportal.abb.com).

See the article numbers in the tables below.

### Controllers

Product	Article numbers for circuit diagrams
<i>Circuit diagram - IRC5</i>	<i>3HAC024480-011</i>
<i>Circuit diagram - IRC5 Compact</i>	<i>3HAC049406-003</i>
<i>Circuit diagram - IRC5 Panel Mounted Controller</i>	<i>3HAC026871-020</i>
<i>Circuit diagram - Euromap</i>	<i>3HAC024120-004</i>
<i>Circuit diagram - Spot welding cabinet</i>	<i>3HAC057185-001</i>

### Robots

Product	Article numbers for circuit diagrams
<i>Circuit diagram - IRB 120</i>	<i>3HAC031408-003</i>
<i>Circuit diagram - IRB 140 type C</i>	<i>3HAC6816-3</i>
<i>Circuit diagram - IRB 260</i>	<i>3HAC025611-001</i>
<i>Circuit diagram - IRB 360</i>	<i>3HAC028647-009</i>
<i>Circuit diagram - IRB 460</i>	<i>3HAC036446-005</i>
<i>Circuit diagram - IRB 660</i>	<i>3HAC025691-001</i>
<i>Circuit diagram - IRB 760</i>	<i>3HAC025691-001</i>
<i>Circuit diagram - IRB 1200</i>	<i>3HAC046307-003</i>
<i>Circuit diagram - IRB 1410</i>	<i>3HAC2800-3</i>
<i>Circuit diagram - IRB 1600/1660</i>	<i>3HAC021351-003</i>
<i>Circuit diagram - IRB 1520</i>	<i>3HAC039498-007</i>
<i>Circuit diagram - IRB 2400</i>	<i>3HAC6670-3</i>
<i>Circuit diagram - IRB 2600</i>	<i>3HAC029570-007</i>
<i>Circuit diagram - IRB 4400/4450S</i>	<i>3HAC9821-1</i>
<i>Circuit diagram - IRB 4600</i>	<i>3HAC029038-003</i>
<i>Circuit diagram - IRB 6400RF</i>	<i>3HAC8935-1</i>
<i>Circuit diagram - IRB 6600 type A</i>	<i>3HAC13347-1</i> <i>3HAC025744-001</i>
<i>Circuit diagram - IRB 6600 type B</i>	<i>3HAC13347-1</i> <i>3HAC025744-001</i>

*Continues on next page*

## 10 Circuit diagram

---

### 10.1 Circuit diagrams

*Continued*

<b>Product</b>	<b>Article numbers for circuit diagrams</b>
<i>Circuit diagram - IRB 6620</i>	<i>3HAC025090-001</i>
<i>Circuit diagram - IRB 6620 / IRB 6620LX</i>	<i>3HAC025090-001</i>
<i>Circuit diagram - IRB 6640</i>	<i>3HAC025744-001</i>
<i>Circuit diagram - IRB 6650S</i>	<i>3HAC13347-1</i> <i>3HAC025744-001</i>
<i>Circuit diagram - IRB 6660</i>	<i>3HAC025744-001</i> <i>3HAC029940-001</i>
<i>Circuit diagram - IRB 6700</i>	<i>3HAC043446-005</i>
<i>Circuit diagram - IRB 7600</i>	<i>3HAC13347-1</i> <i>3HAC025744-001</i>
<i>Circuit diagram - Product.ProductName</i>	<i>3HAC050778-003</i>
<i>Circuit diagram - IRB 910SC</i>	<i>3HAC056159-002</i>

# Index

## A

Absolute Accuracy, calibration, 339  
 Absolute Accuracy, guiding sleeves, 70  
 air connections, pressure, 123  
 aluminum  
   disposal, 369  
 ambient humidity  
   operation, 53  
   storage, 53  
 ambient temperature  
   operation, 53  
   storage, 53  
 arm system  
   replacing, 178  
 assembly instructions, 49  
 assessment of hazards and risks, 20  
 attachment bolts, robot-foundation, 69  
 Axis Calibration, 349  
   calibration tool  
     article number, 352, 358  
     examining, 352  
     installation position, 354  
   overview of method, 349  
   procedure on FlexPendant, 358  
   protective cover and protection plug, 354, 358

## B

backshells, customer connection, 123  
 base  
   brake release buttons, 66  
   hole configuration, 68  
   replacing, 239  
   screws, tightening torque, 243  
   spare part number, 239  
 batteries  
   disposal, 369  
   handling, 37  
 battery  
   replacing, 144  
 battery pack  
   replacing, interval, 129  
   spare part number, 146  
 battery shutdown  
   service routine, 144  
 belt tightener axis 5  
   article number, 288  
   measure, 289  
 brake release unit  
   releasing the brakes, 66  
   replacing, 251  
   spare part number, 252  
 brakes  
   testing function, 36  
 brakes, releasing  
   external power supply to connector R1.MP, 67  
   manually, 66  
   power supply on motor axis 1, 259  
   power supply to motor axis 2, 264  
   power supply to motor axis 3, 271  
   power supply to motor axis 4, 281

## C

cabinet lock, 25, 31  
 cable harness

inside base, figure, 169  
 inside frame, figure, 168  
 inside upper arm, figure, 166  
   replacing, 162  
   spare part number, 162  
 cabling  
   inside base, figure, 169  
   inside frame, figure, 168  
   inside upper arm, figure, 166  
   replacing, 162  
   spare part number, 162  
 cabling, robot, 119  
 cabling between robot and controller, 119  
 calibrating  
   robot, 349  
   roughly, 345  
 calibrating robot, 349  
 calibration  
   Absolute Accuracy type, 338  
   rough, 345  
   standard type, 338  
   verification, 367  
   when to calibrate, 340  
 calibration, Absolute Accuracy, 339  
 calibration manuals, 339  
 calibration marks, 341  
 calibration position  
   jogging to, 368  
   scales, 341  
 calibration scales, 341  
 CalibWare, 338  
 carbon dioxide extinguisher, 22  
 cast iron  
   disposal, 369  
 cleaning, 149  
   robot, interval, 129  
 climbing on robot, 25  
 Cold environments, 126  
 complete arm system  
   replacing, 178  
 connecting the robot and controller, cabling, 119  
 connection  
   external safety devices, 26  
 connectors  
   air, 123  
   customer, 123  
   MIL-C-26482 series 1, 125  
   R2.CS and R2.CP  
     pins, customer connection, 123  
   Souriau, 124  
 copper  
   disposal, 369  
 cracks, damper, 134

## D

damage, damper, 134  
 damper, axis 2, 132  
   attachment screw, 221  
   replacing, 220  
   spare part number, 220  
 damper, axis 3  
   inspection, 132  
   replacing, 222  
   spare part number, 222  
 damper, axis 5  
   inspection, 132  
   replacing, 226

- spare part number, 226

- danger levels, 40

- dimensions

- guiding sleeves, 69

- mounting surface, 69

- robot, 79

- dimensions, IRB 1600, 81

- dimensions, IRB 1600ID, 82

- dimensions, IRB 1660ID, 83

- direction of axes, 344

## E

- enabling device, 30

- environmental information, 369

- equipment, robot, 79

- ESD

- damage elimination, 33

- sensitive equipment, 33

- external safety devices, 26

- extra equipment, 79

## F

- figures

- base, hole configuration, 68

- brake release buttons, 66

- cabling inside base, 169

- cabling inside frame, 168

- cabling inside upper arm housing, 166

- mounting surface, 69

- power supply to connector R1.MP, 67

- fire extinguishing, 22

- fitting, equipment, 79

- FlexPendant

- jogging to calibration position, 368

- MoveAbsJ instruction, 368

- updating revolution counters, 346

- foundation

- requirements, 52

- frame

- replacing, 329

- spare part number, 330

## G

- gaskets, spare part number

- base cover, 252

- gearbox axis 1-2, 257

- upper arm cover, 311

- upper arm customer connections, 311

- gearbox, axes 1-2

- replacing, 329

- spare part number, 330

- gearboxes

- location of, 137

- gearboxes, axes 3-6

- replacing, 335

- service work, 335

- gearboxes, axes 5 and 6

- oil change, 138

- Gravity Alpha, 73

- Gravity Beta, 73

- grease

- disposal, 369

## H

- hanging

- installed hanging, 25

- hazardous material, 369

- height

- installed at a height, 25

- hold-to-run, 30

- hole configuration

- base, 68

- HRA, 20

- humidity

- operation, 53

- storage, 53

## I

- illustrations

- base, hole configuration, 68

- brake release buttons, 66

- cabling inside base, 169

- cabling inside frame, 168

- cabling inside upper arm housing, 166

- mounting surface, 69

- power supply to connector R1.MP, 67

- inspection, 132

- installation

- equipment, 79

- mechanical stop axis 2, 105

- mechanical stops, axis 1, 100

- mechanical stops axis 3, 109

- position switch axis 1, 113

- robot, attachment bolts, 69

- signal lamp, 92

- instructions for assembly, 49

- integrator responsibility, 19

- intervals, maintenance, 129

## L

- labels

- robot, 42

- lamp unit

- article number, 93

- installation, 92

- leak-down test, 154

- lifting

- accessory, 65

- lifting, robot, 63

- lifting accessory, 382

- limitation of liability, 19

- Lithium

- disposal, 369

- load areas, 79

- loads on foundation, 51

- lower arm

- removing together with upper arm, 178

- replacing, 196

- screws, tightening torque, 199

- spare part number, 196

- lubrication

- amount in gearboxes, 137

- type of lubrication, 137

## M

- magnesium

- disposal, 369

- maintenance intervals, 129

- maintenance schedule, 129

- measurement system battery pack, spare part

- number, 146

- mechanical stop axis 2

- article number, 107

- installation, 105

- mechanical stop axis 3
    - article number, 111
    - screws, tightening torque, 112
  - mechanical stops axis 1
    - article number, 102
    - installation, 100
    - screws, tightening torque, 103
  - mechanical stops axis 2
    - screws, tightening torque, 107
  - mechanical stops axis 3
    - installation, 109
  - motor axis 1
    - brake release with power supply, 259
    - replacing, 257
    - spare part number, 257
    - tightening torque, 260
  - motor axis 2
    - brake release with power supply, 264
    - replacing, 262
    - spare part number, 262
    - tightening torque, 266
  - motor axis 3
    - brake release with power supply, 271
    - replacing, 268
    - screws, tightening torque, 271, 277
    - spare part number, 268
  - motor axis 4
    - brake release with power supply, 281
    - replace, 279
    - screws, tightening torque, 282, 287
    - spare part number, 279
  - motor axis 5
    - replacing, 288
    - screws, tightening torque, 292
    - spare part number, 288
  - motor axis 6
    - replacing, 311
    - screws, tightening torque, 314
    - spare part number, 311
  - mounting, equipment, 79
  - mounting holes IRB 1600, 84
  - mounting holes IRB 1600ID, 86
  - mounting holes IRB 1660ID, 88
  - MoveAbsJ instruction, 368
- N**
- nation specific regulations, 19
  - negative directions, axes, 344
  - neodymium
    - disposal, 369
  - NiCad
    - disposal, 369
  - nodular iron
    - disposal, 369
- O**
- oil
    - amount in gearboxes, 137
    - disposal, 369
    - type of oil, 137
  - oil change
    - gearbox axes 5 and 6, 138
    - gearboxes, axes 5 and 6, intervals, 129
    - safety risks, 38
    - wrist unit, 138
    - wrist unit, intervals, 129
  - operating conditions, 53
  - orienting, robot, 68
- P**
- pedestal
    - installed on pedestal, 25
  - plastic
    - disposal, 369
  - position, robot
    - when draining wrist unit, 139, 142–143
    - when filling oil in wrist unit, 140
  - positions at wrist center
    - IRB 1600 - 1.2 m reach, 56
    - IRB 1600 - 1.45 m reach, 57
    - IRB 1600ID-4/1.5, 58
    - IRB 1660ID, 59
  - position switch
    - axis 1, 113
  - position switch axis 1
    - article number, 114
  - positive directions, axes, 344
  - product standards, 376
  - protection classes, 54
  - protection type, 54
  - protective equipment, 26
  - protective wear, 26
  - push button unit
    - releasing the brakes, 66
    - replacing, 251
    - spare part number, 252
- R**
- range of movement
    - IRB 1600, 55
    - IRB 1600ID, 55
    - IRB 1660ID, 55
  - region specific regulations, 19
  - release brakes, 23
  - releasing brakes
    - external power supply to connector R1.MP, 67
    - manually, 66
  - replacing together, 178
  - requirements on foundation, 52
  - responsibility and validity, 19
  - restricting working range
    - axis 1, 100, 113
    - axis 2, 105
    - axis 3, 109
  - revolution counters
    - storing on FlexPendant, 346
    - updating, 345
  - risk of tipping, 61
  - robot
    - dimensions, 79
    - equipment, fitting, 79
    - labels, 42
    - lifting, 63
    - orienting and securing, 68
    - protection class, 54
    - protection types, 54
    - symbols, 42
  - robot position
    - when draining wrist unit, 139, 142–143
    - when filling oil in wrist unit, 140
  - rubber
    - disposal, 369

## S

- safety
  - brake testing, 36
  - ESD, 33
  - fire extinguishing, 22
  - moving robots, 27
  - release robot axes, 23
  - signals, 40
  - signals in manual, 40
  - symbols, 40
  - symbols on robot, 42
  - test run, 28
  - working range, 29
- safety equipment
  - position switch axis 1, 113
- safety fence, 20
- safety risk
  - electric parts, 31
  - hot parts, 34
  - hydraulic system, 35
  - installation, 25
  - oil change, 38
  - operational disturbance, 25
  - pneumatic system, 35
  - service work, 25
  - voltage, 31
- safety signals
  - in manual, 40
- safety standards, 376
- safety zones, 20
- scales on robot, 341
- schedule, maintenance, 129
- screw joints, 379
- securing, robot, 68–69
- serial measurement unit
  - battery pack, spare part number, 146
  - replacing, 244
  - spare part number, 246
- signal lamp
  - article number, 93
  - installation, 92
- signals
  - safety, 40
- SMB battery
  - extension of lifetime, 144
  - replacing, 144
- SMB unit
  - battery pack, spare part number, 146
  - replacing, 244
  - spare part number, 246
- Souriau, connector, 124
- special tools, 384
- speed
  - adjusting, 126
- stability, 61
- standards, 376
  - ANSI, 377
  - CAN, 377
  - EN, 376
  - EN IEC, 376
  - EN ISO, 376
- start of robot in cold environments, 126
- steel
  - disposal, 369
- storage conditions, 53
- suspended mounting, 72

## symbols

- safety, 40
- synchronization position, 345
- sync marks, 341
- system integrator requirements, 19
- system parameter
  - Gravity Alpha, 73
  - Gravity Beta, 73

## T

- temperatures
  - operation, 53
  - storage, 53
- testing
  - brakes, 36
- three-position enabling device, 30
- tightening torques, attachment screws
  - base-gearbox unit, 243
  - lower arm-frame, 199
  - mechanical stop axis 1, 103
  - mechanical stop axis 2, 107
  - mechanical stop axis 3, 112
  - motor axis 1, 260
  - motor axis 2, 266
  - motor axis 3, 271, 277
  - motor axis 4, 282, 287
  - motor axis 5, 292
  - motor axis 6, 314
  - robot to foundation, attachment bolts, 69
  - upper arm, 187
  - wrist unit, 204
- tilted mounting, 72
- timing belt axis 5
  - adjusting the tension, 292
  - replacing, 288
  - spare part number, 288
- timing belt axis 6
  - adjusting the tension, 314
  - replacing, 311
  - spare part number, 311
- tools
  - Axis Calibration, 385
  - belt tightener axis 5, article number, 288
  - belt tightener axis 5, measure, 289
  - Calibration Pendulum, 384
  - dynamometer axis 5 and 6, 311
  - for service, 384
  - hook axis 6, article number, 311
  - rotational tool, article number, 279
- torques on foundation, 51
- troubleshooting
  - oil spills, 149
- turning
  - accessory, 65
- turning radius, 60

## U

- updating revolution counters, 345
- upper and lower arm, 178
- upper arm
  - removing together with lower arm, 178
  - replacing, 183
  - screws, tightening torque, 187
  - spare part number, 184

## V

- validity and responsibility, 19

- velocity
  - adjusting, 126
- verifying calibration, 367
- VK-covers, spare part number
  - at base, 239
  - lower arm, lower, 196
  - lower arm, middle, 196
  - lower arm, upper, 184
- W**
- wall mounting, 72
- weight, 51
  - arm, 180–181
  - base, 242, 332, 334
  - gearbox 1, 332–334
  - robot, 64, 198–199, 241, 243, 382
  - upper arm, 185–186, 191, 193
  - upper arm tube, 298
- working range, 55
  - restricting axis 1, 113
- wrist unit
  - oil change, 138
  - replacing, 201
  - screws, tightening torque, 204
  - spare part number, 201
- Z**
- zero position
  - checking, 368









**ABB AB, Robotics**

**Robotics and Motion**

S-721 68 VÄSTERÅS, Sweden

Telephone +46 (0) 21 344 400

**ABB AS, Robotics**

**Robotics and Motion**

Nordlysvegen 7, N-4340 BRYNE, Norway

Box 265, N-4349 BRYNE, Norway

Telephone: +47 22 87 2000

**ABB Engineering (Shanghai) Ltd.**

Robotics and Motion

No. 4528 Kangxin Highway

PuDong District

SHANGHAI 201319, China

Telephone: +86 21 6105 6666

**ABB Inc.**

**Robotics and Motion**

1250 Brown Road

Auburn Hills, MI 48326

USA

Telephone: +1 248 391 9000

**[abb.com/robotics](http://abb.com/robotics)**